

V12 V12
V25 V25
V33.A V33.A
V33.B V33.B
V33.C V33.C
V33.D V33.D
VRF.A VRF.A
VRF.B VRF.B
VRF.C VRF.C
VRF.D VRF.D
GND GND

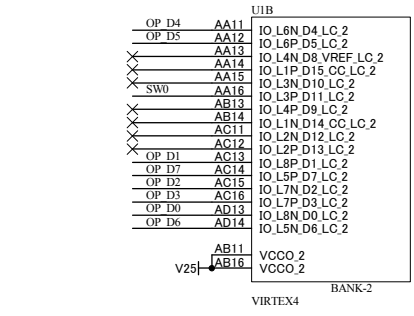
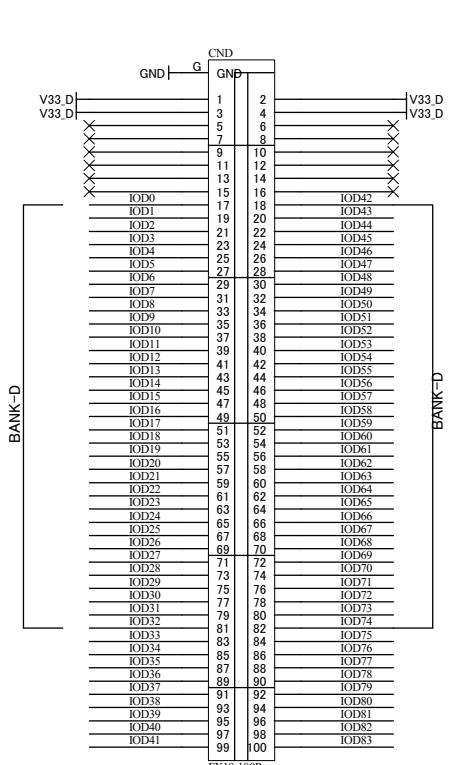
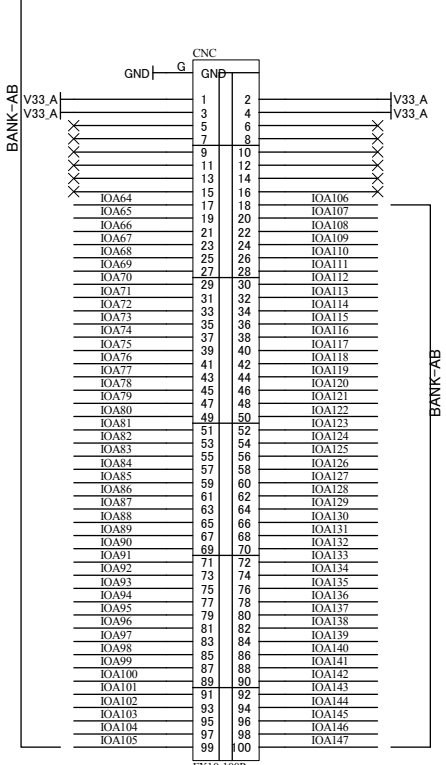
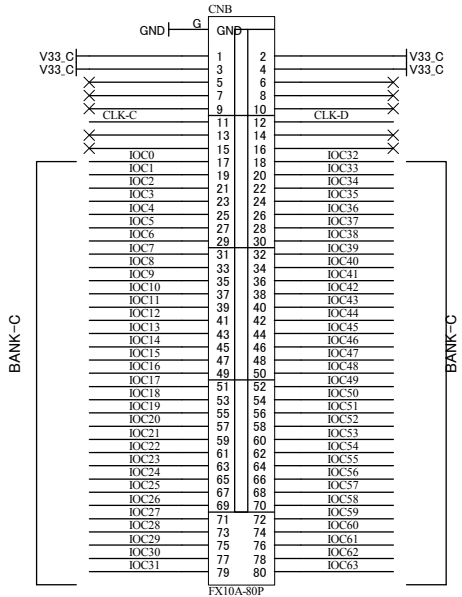
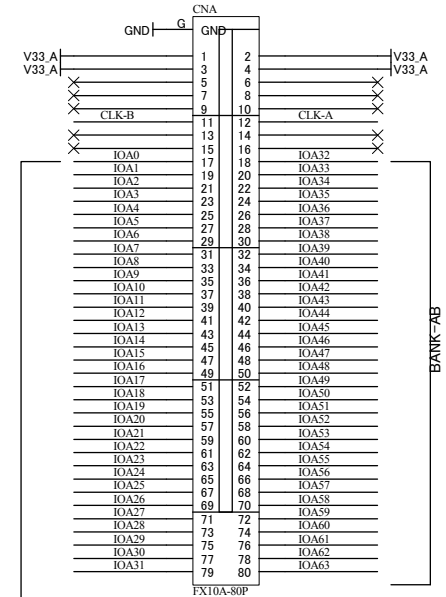
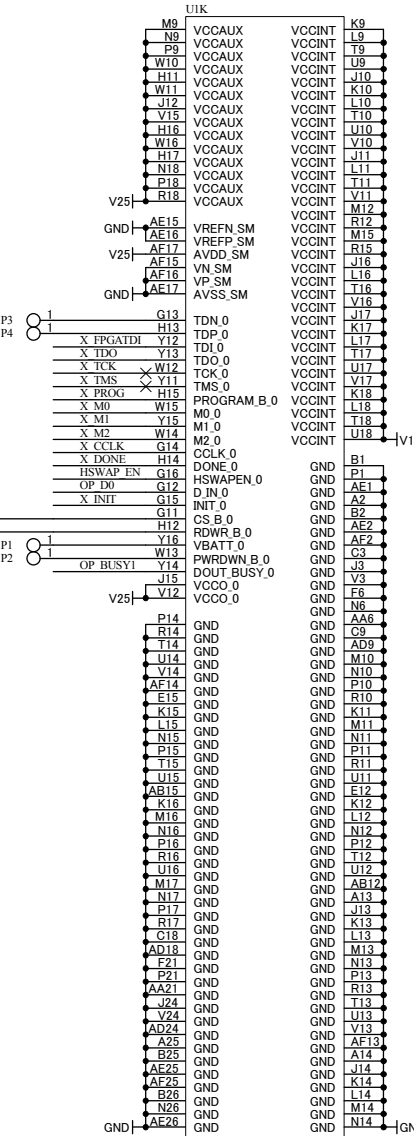
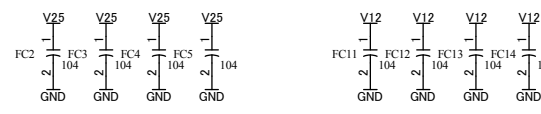
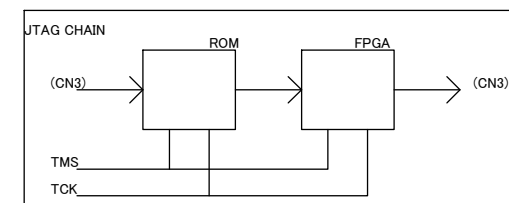
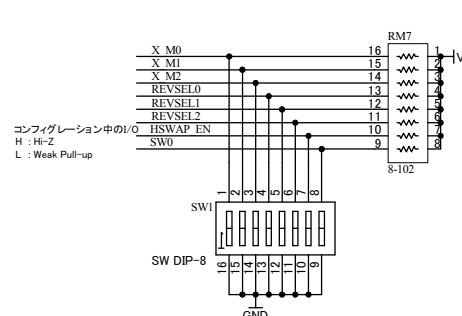
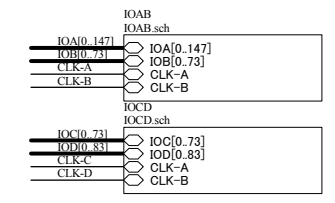
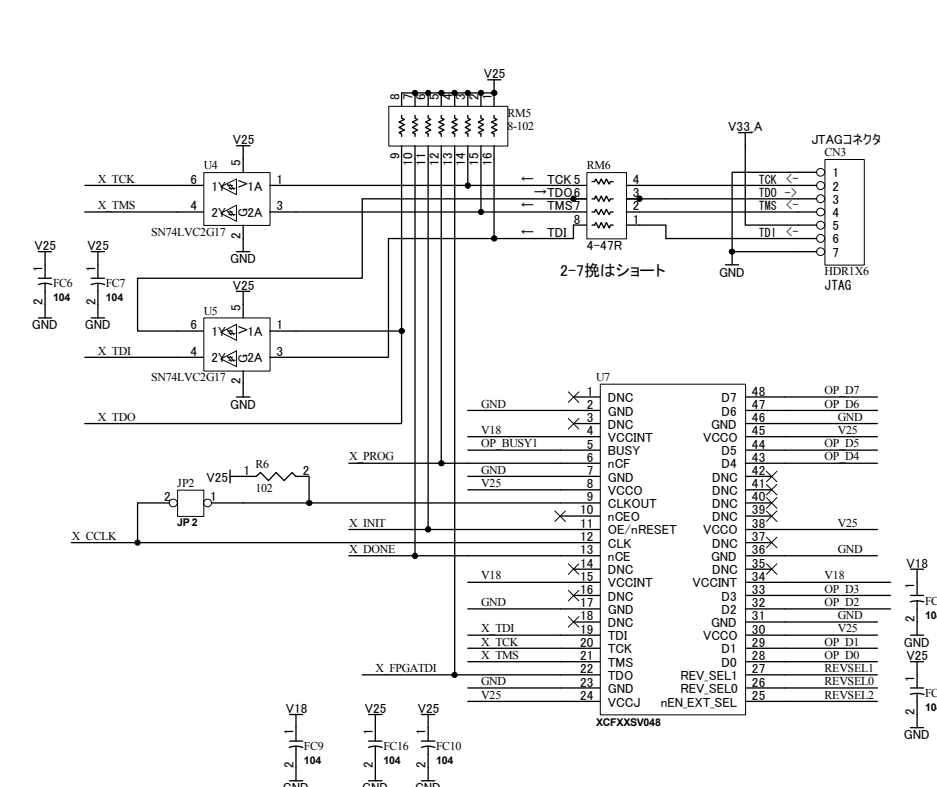
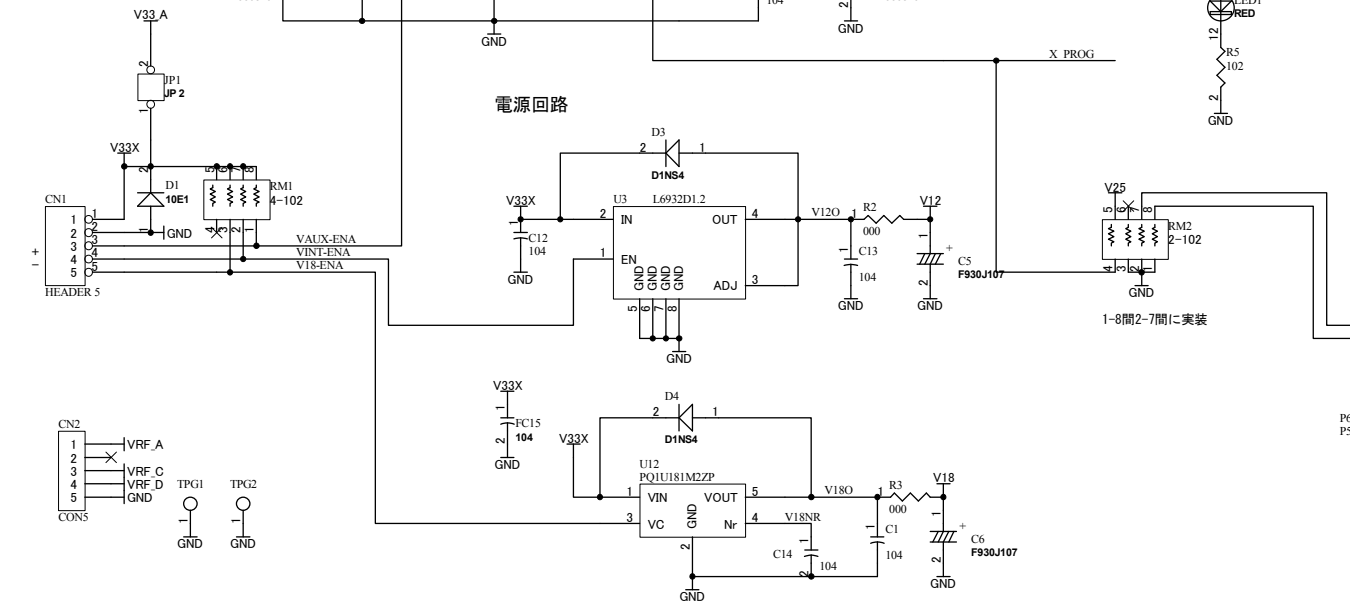

HUMAN DATA

2006/04/18

HuMANDATA LTD.
OSAKA JAPAN
www.hdl.co.jp

Virtex4FF668EVABOARD

XCM-201

B1

V12	V12
V25	V25
V33_A	V33_A
V33_B	V33_B
V33_C	V33_C
V33_D	V33_D
VRF_A	VRF_A
VRF_B	VRF_B
VRF_C	VRF_C
VRF_D	VRF_D
GND	GND

IOA[0..147]	IOA[0..147]
IOB[0..73]	IOB[0..73]

CLK-A	GCLK3
CLK-B	GCLK4

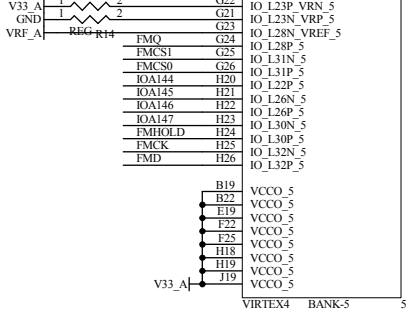
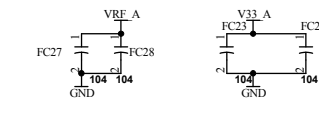
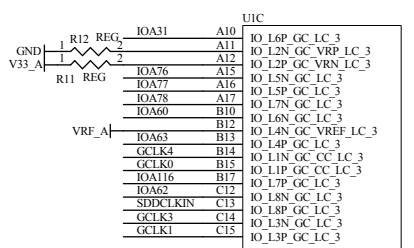
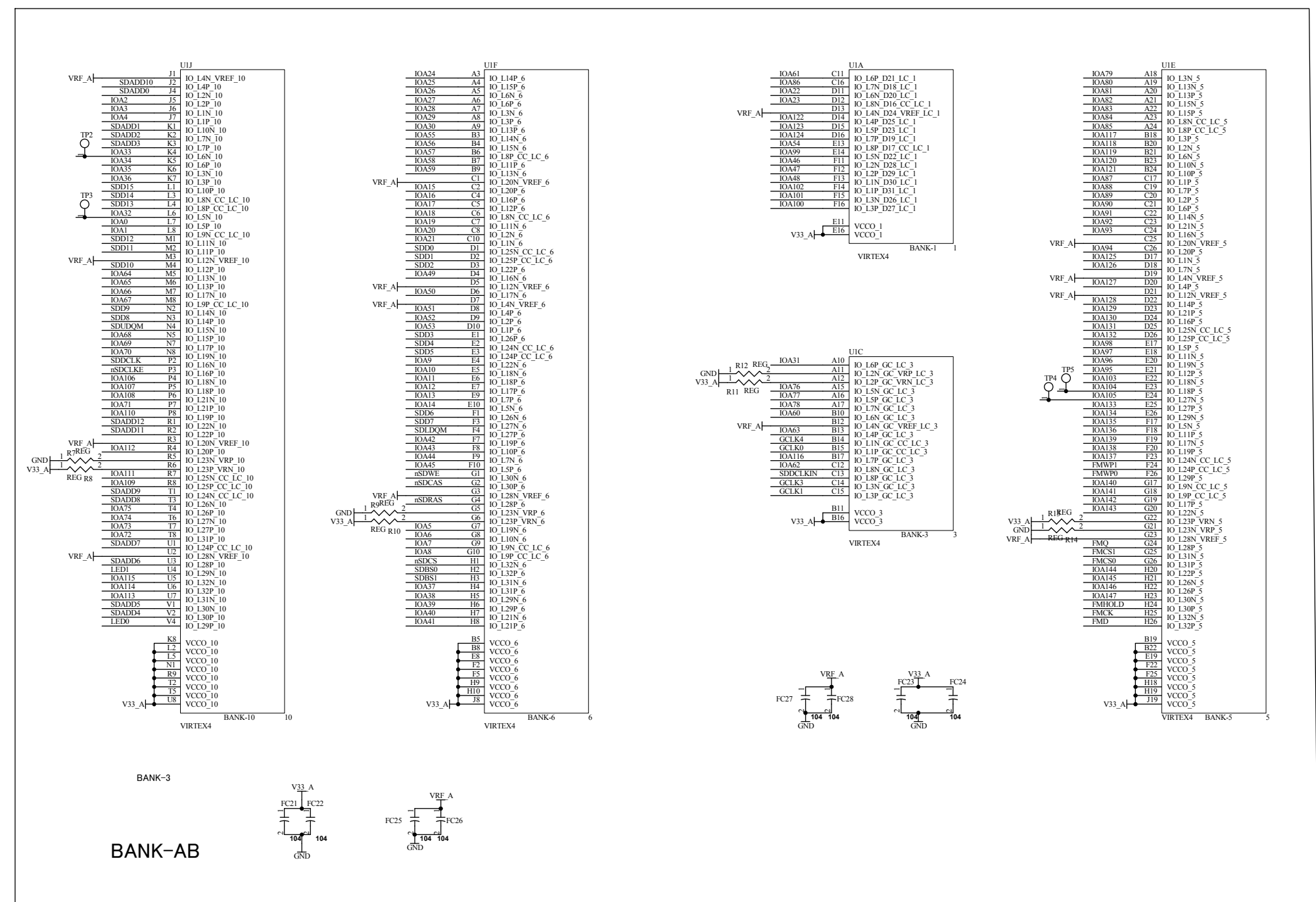
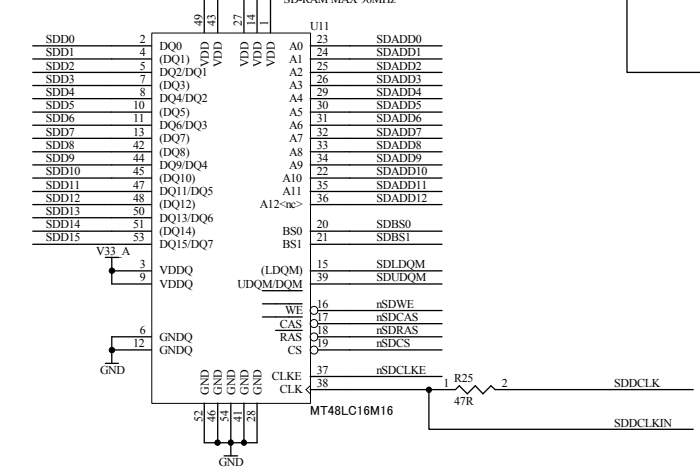
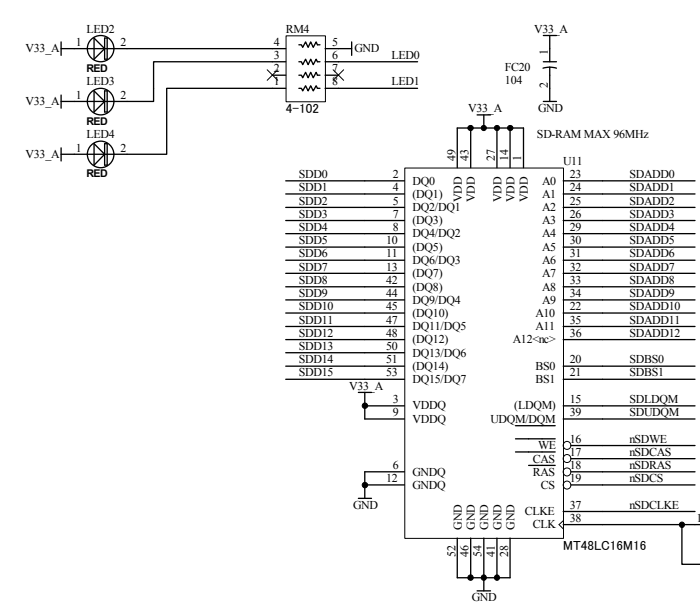
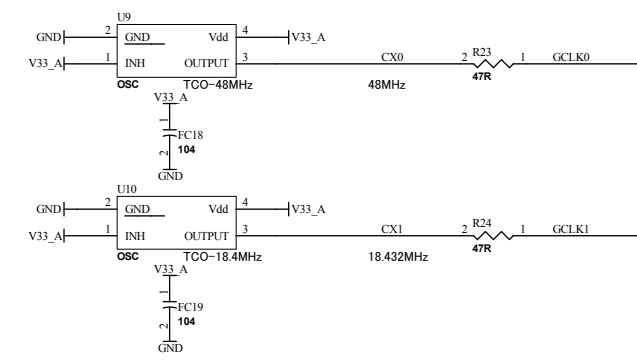
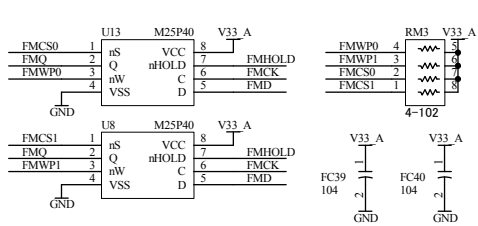

HUMAN DATA

HuMANDATA LTD.
OSAKA JAPAN
www.hdl.co.jp

Virtex4FF668EVABORD

V12	V12
V25	V25
V33_A	V33 A
V33_B	V33 B
V33_C	V33 C
V33_D	V33 D
VRF_A	VRF A
VRF_B	VRF B
VRF_C	VRF C
VRF_D	VRF D
GND	GND

IOC0.63	IOC0.63
IOD0.83	IOD0.83
CLK-A	GCLK5
CLK-B	GCLK6

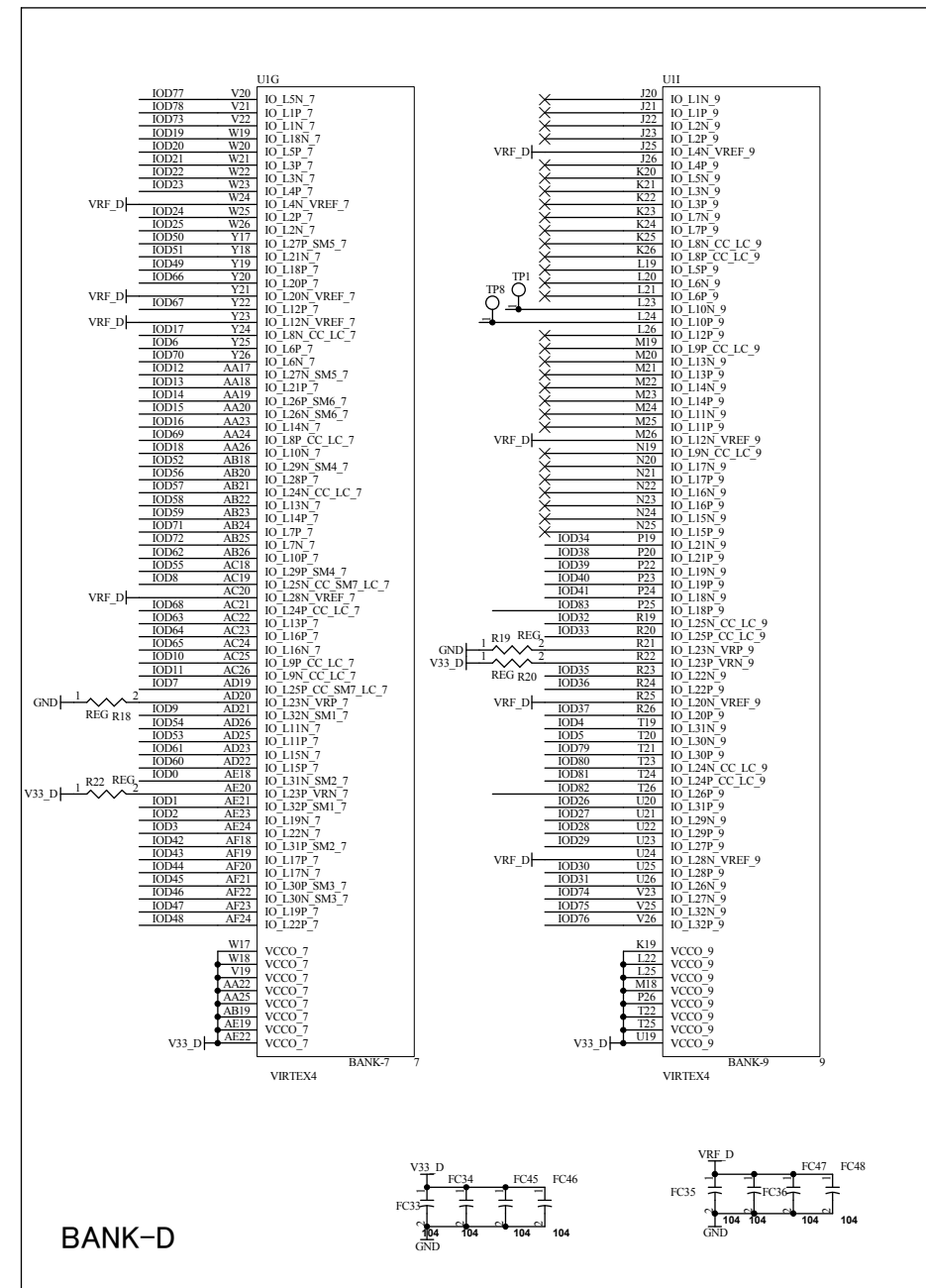
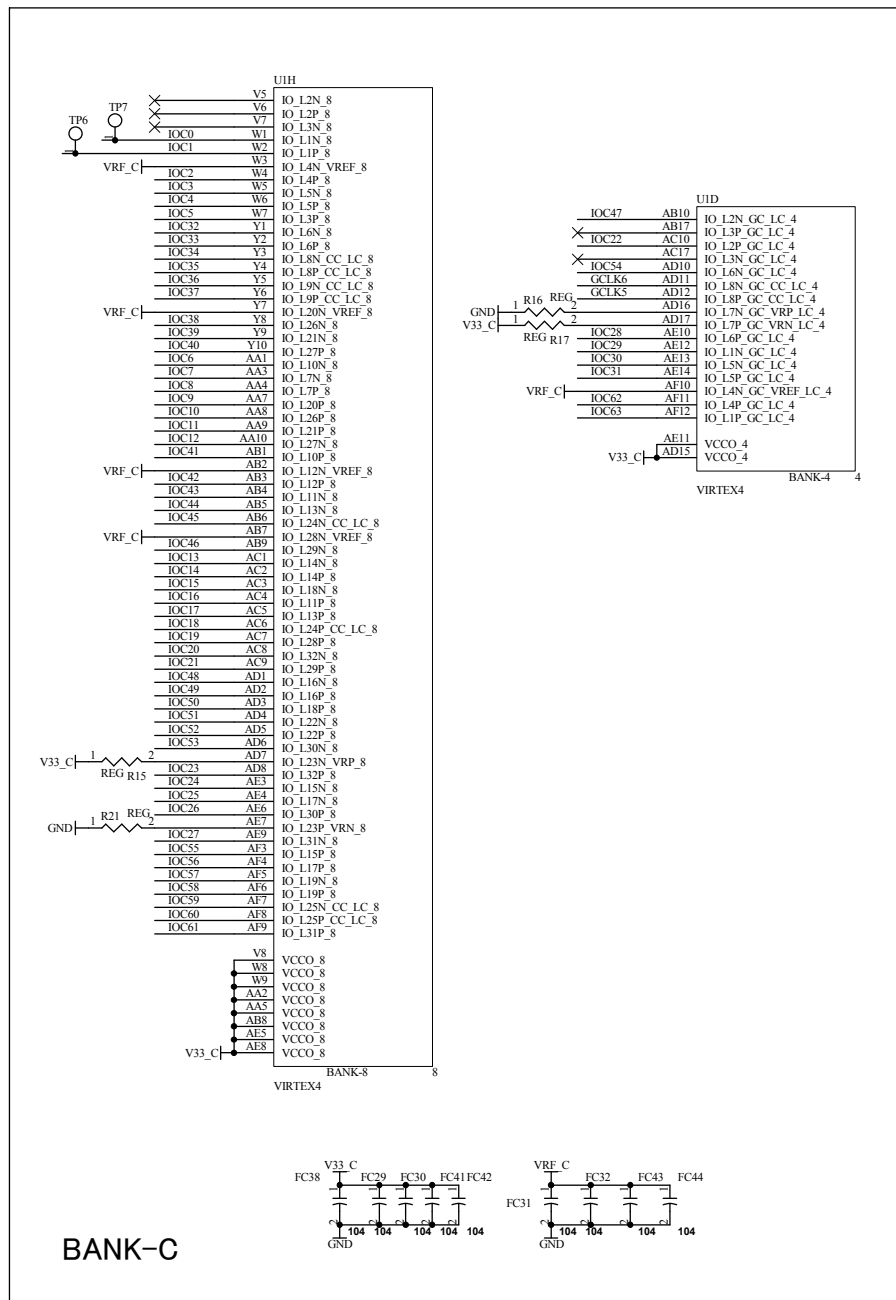

HUMAN DATA

HuMANDATA LTD.
OSAKA JAPAN
www.hdl.co.jp

Virtex4FF668EVABOARD

Date: 18-Apr-2006

10:05:57

File: IOCD.sch

DOC. No.

XCM-201

B

Sheet 3 of 3