

A

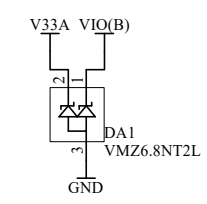

B

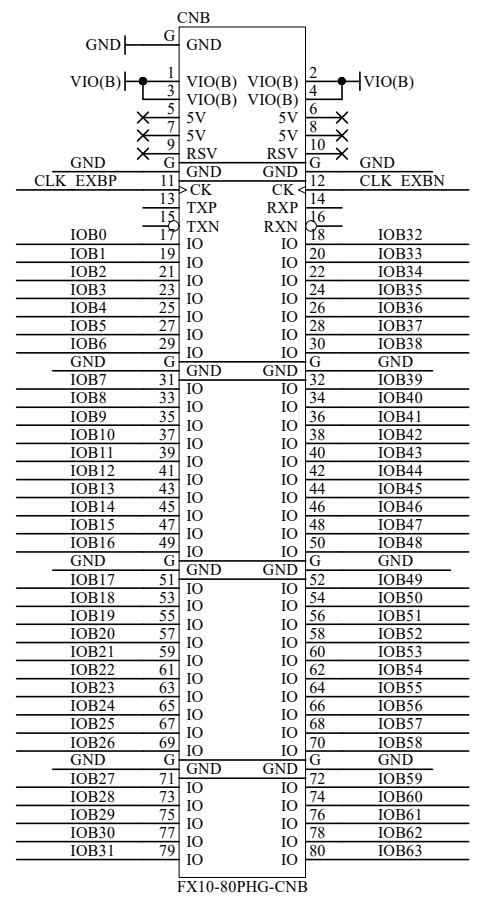
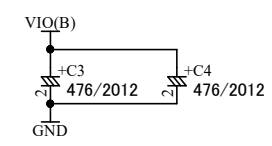
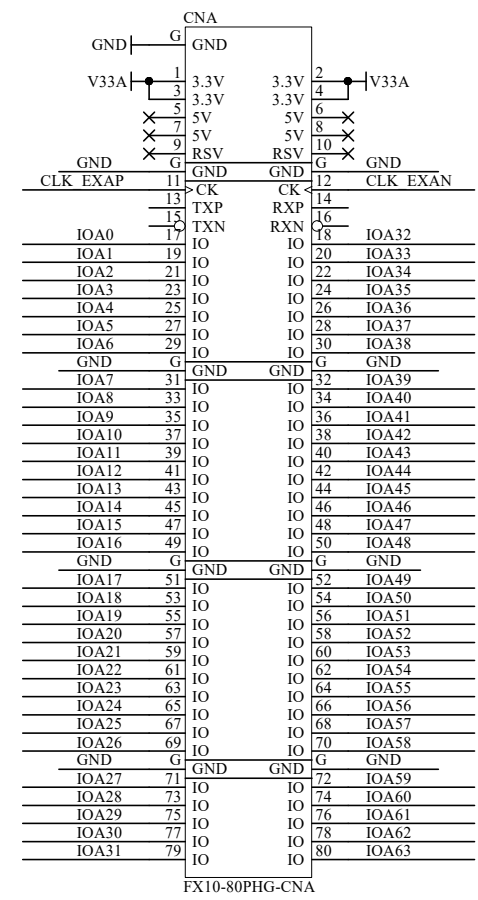
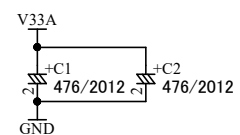
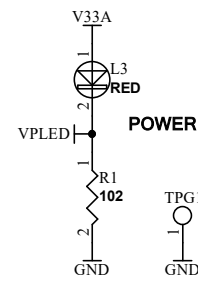
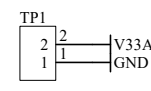

C

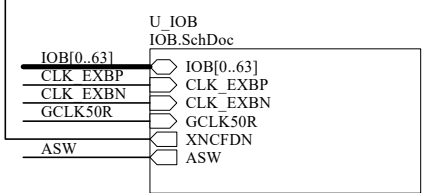
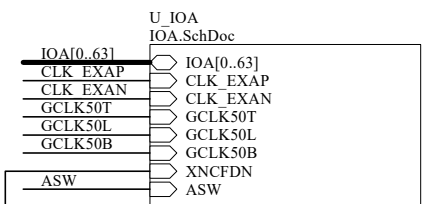
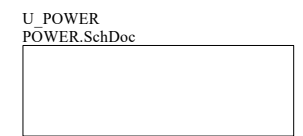
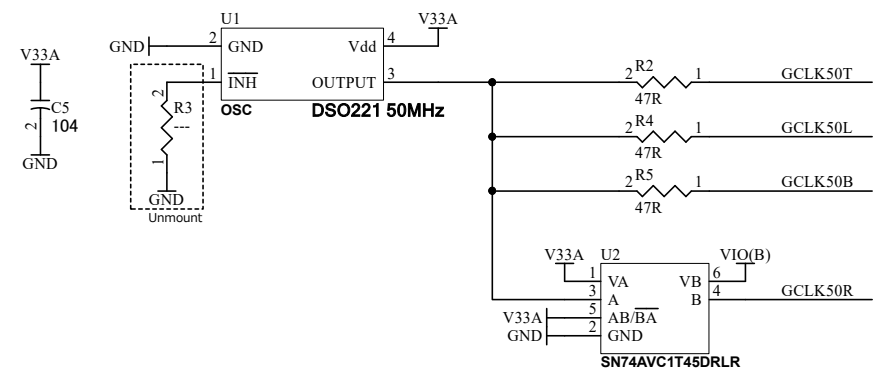

D

ACM114R1-SCH-A.pdf



DSN:	TITLE: Intel Cyclone 10 LP F484 FPGA Board
DOC. No: ACM-114	A
FILE: ACM114.SchDoc	DATE: 2018/01/11 9:45:07
Sheet: 1 / 4	V5.20150107

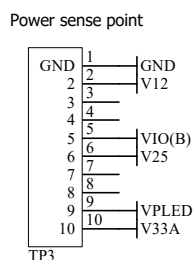
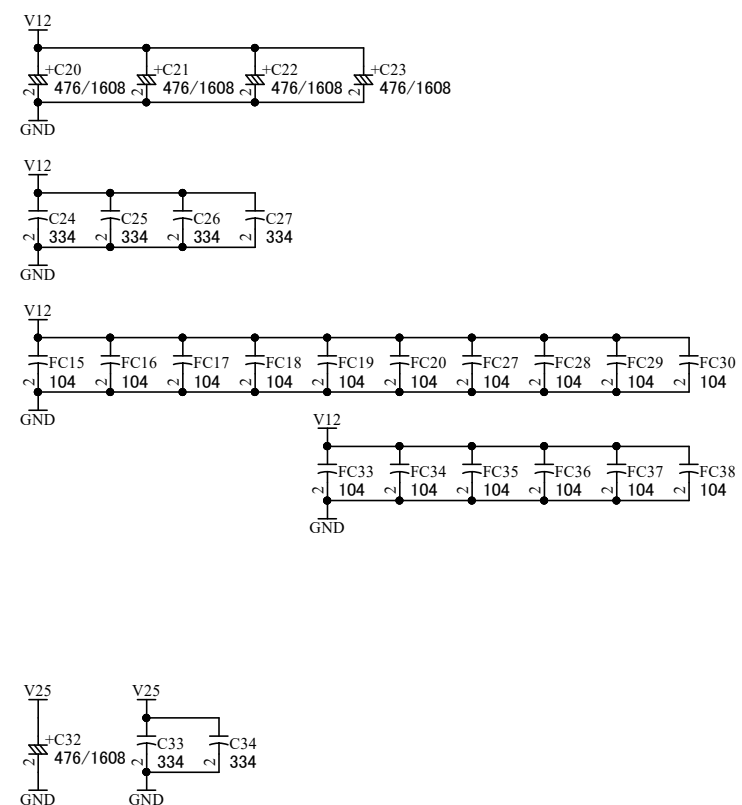
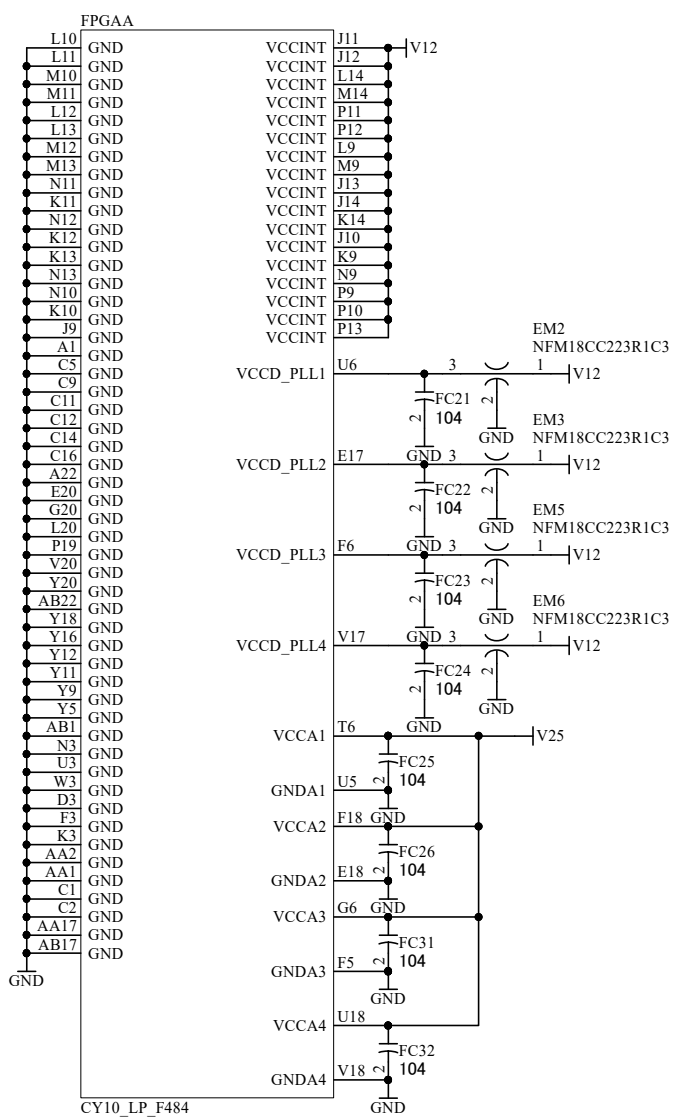
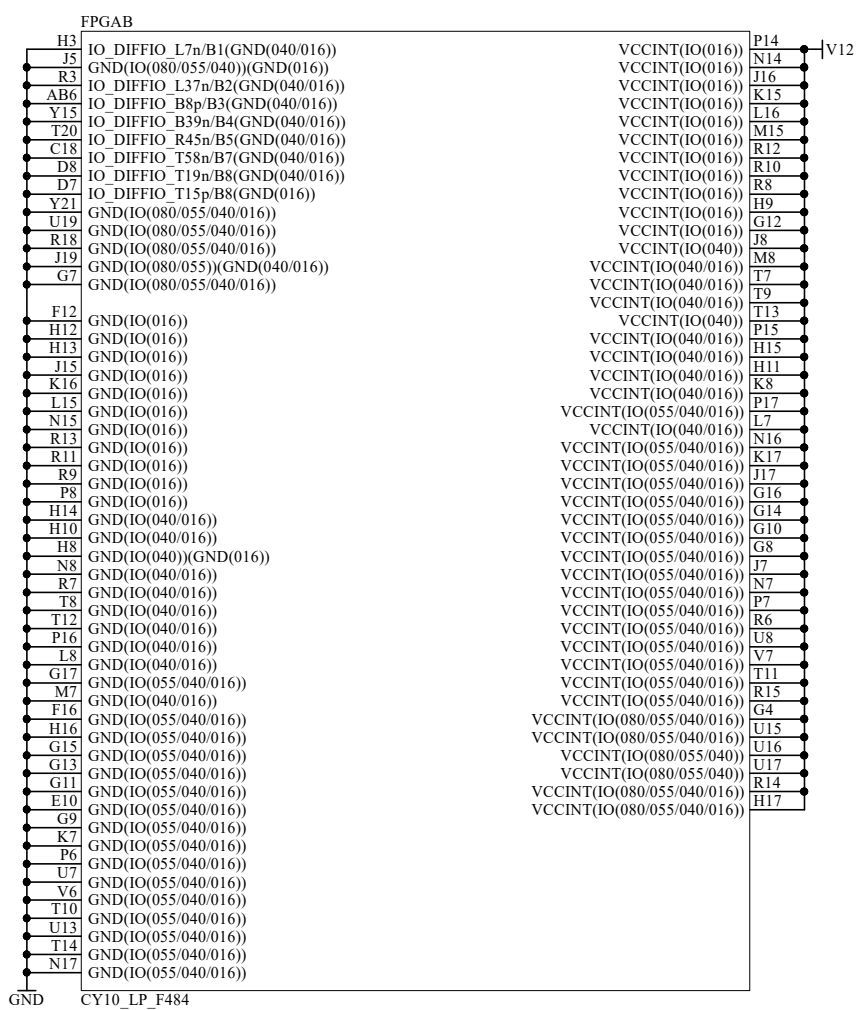
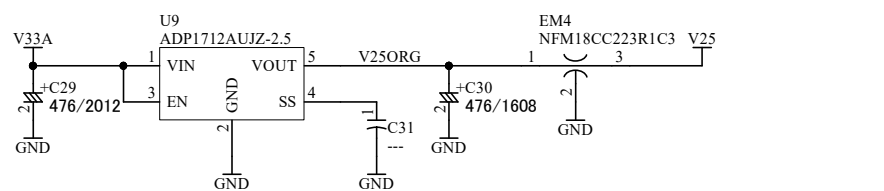
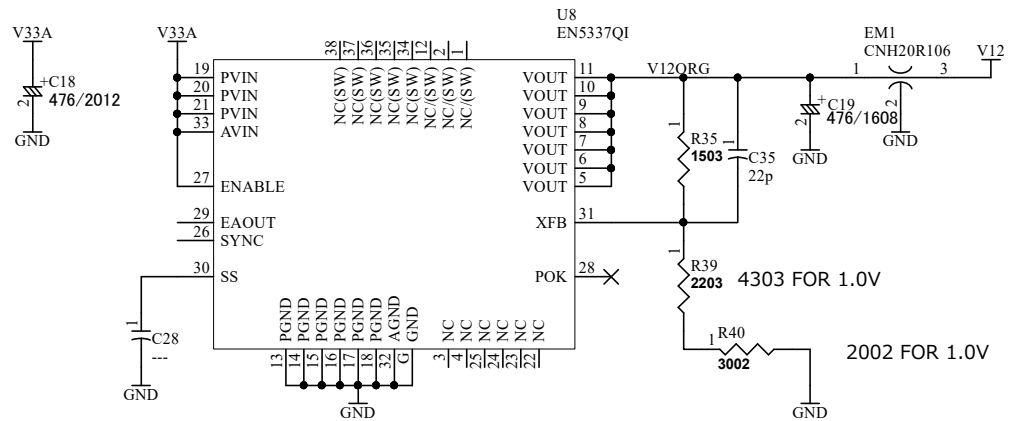

ACM114R1-SCH-A.pdf

HUMAN DATA
HuMANDATA LTD.
www.hdl.co.jp

DSN:	TITLE: Intel Cyclone 10 LP F484 FPGA Board
DOC. No:	ACM-114
FILE: POWER.SchDoc	DATE: 2018/01/11 9:45:07
Sheet:	A
V5.20150107	

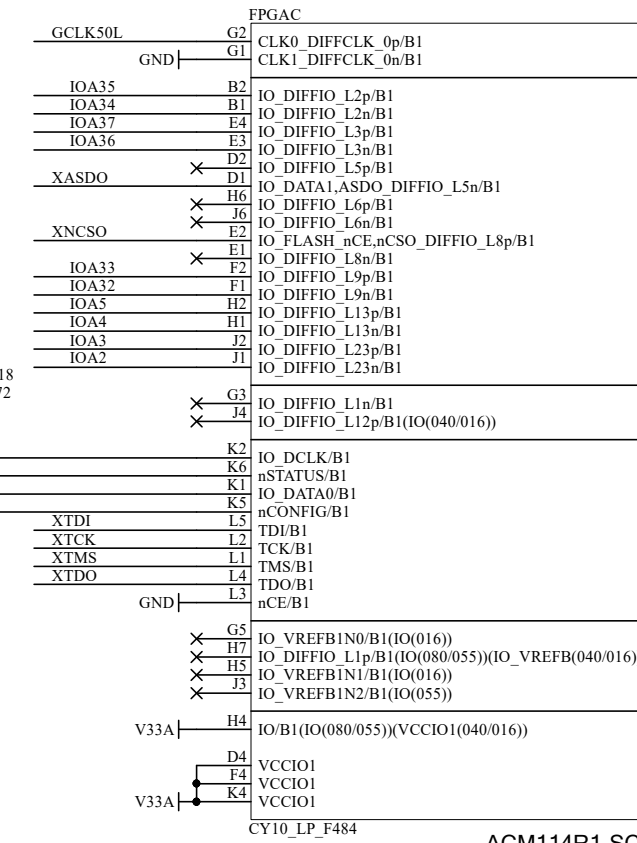
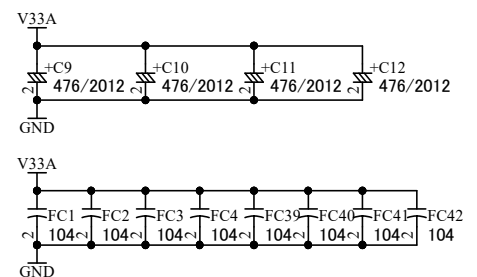
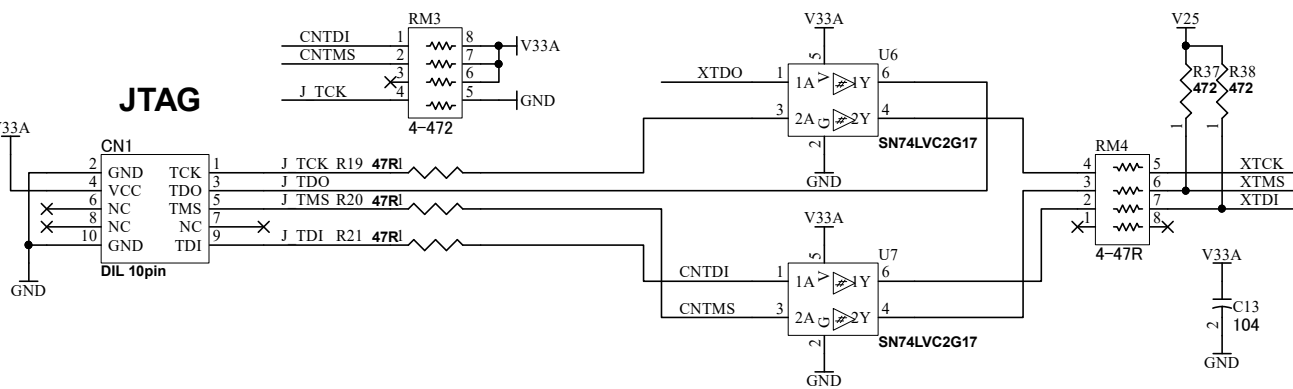
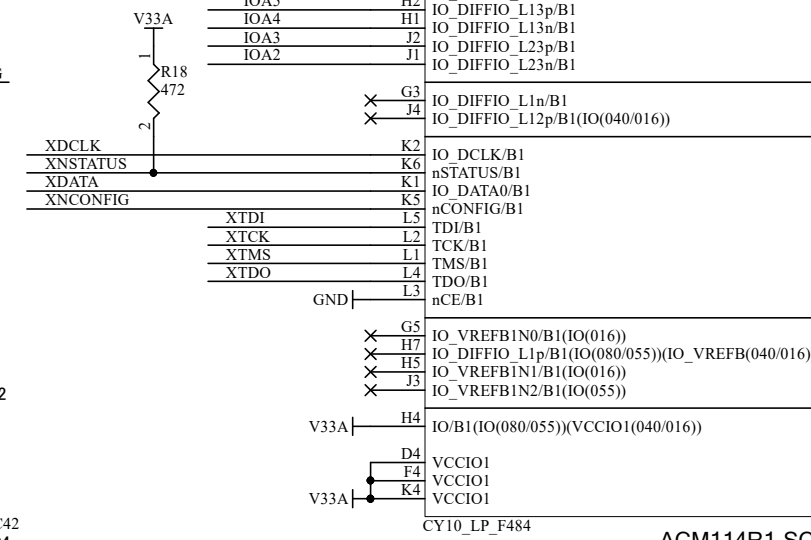
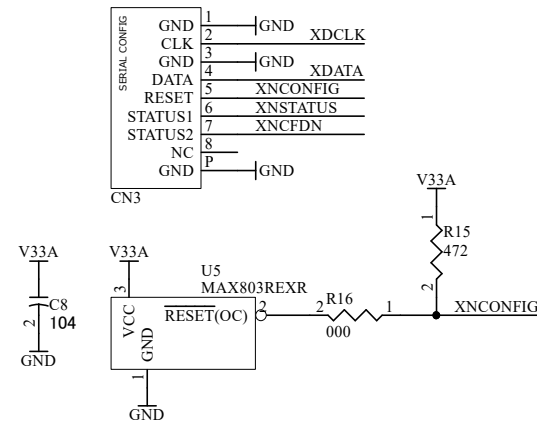
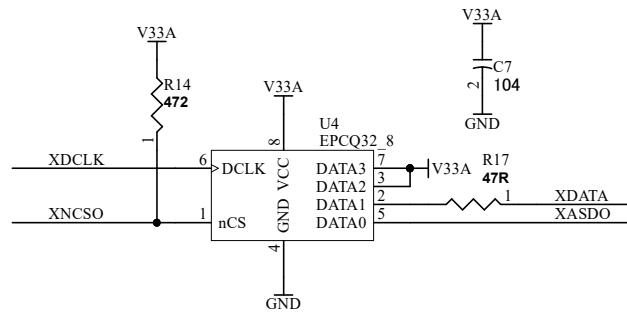
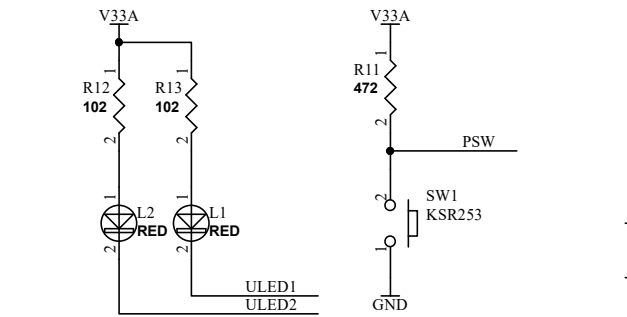
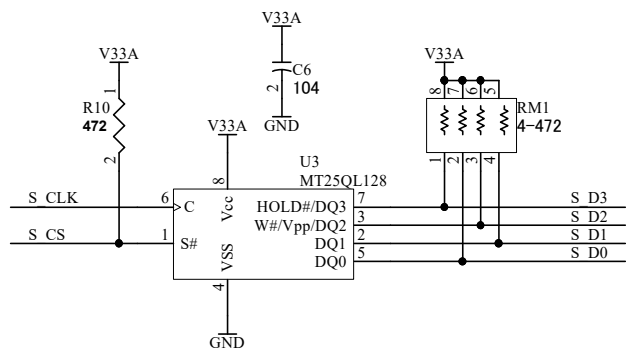
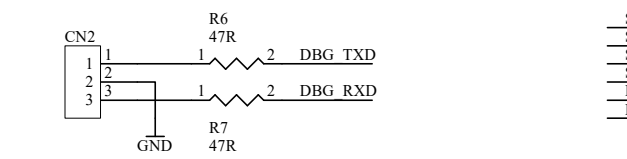
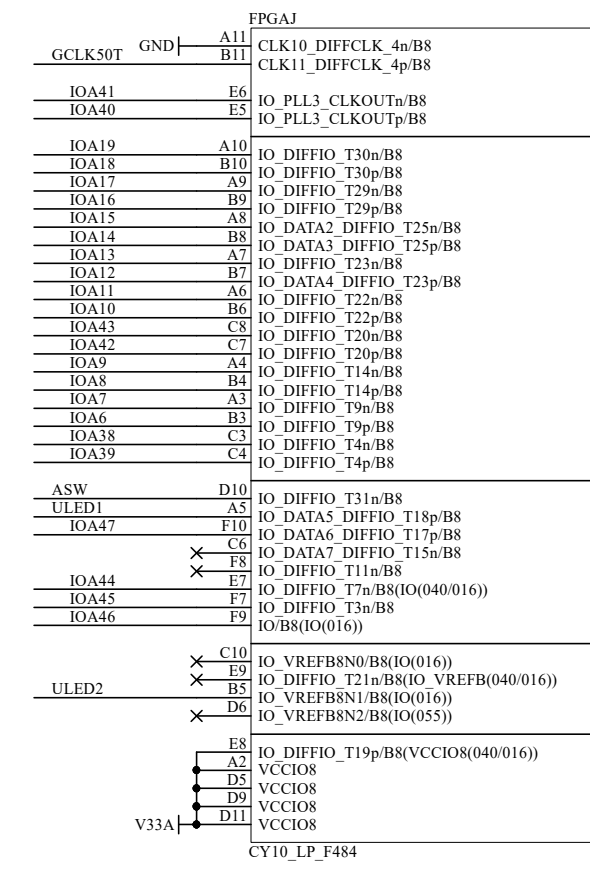
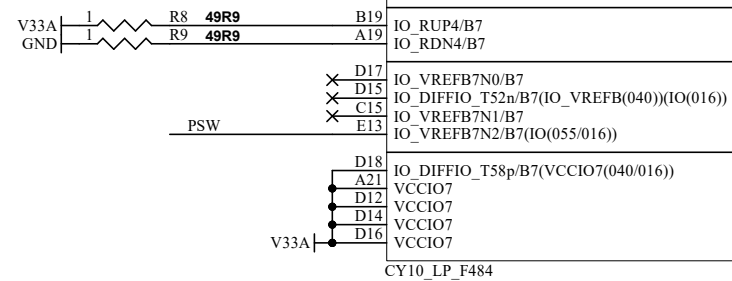
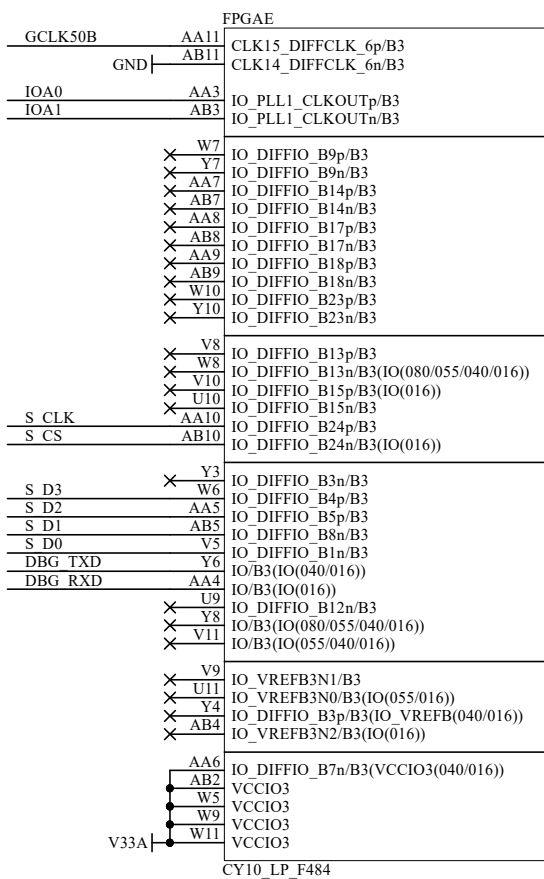
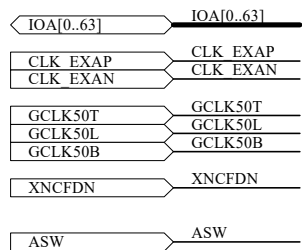

ACM114R1-SCH-A.pdf



DSN:	TITLE: Intel Cyclone 10 LP F484 FPGA Board
DOC. No:	ACM-114
FILE: IOA.SchDoc	DATE: 2018/01/11 9:45:07
Sheet:	3 / 4

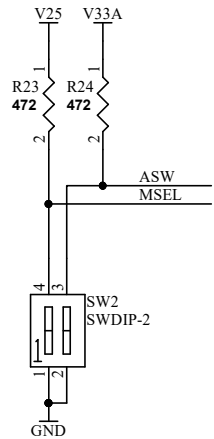
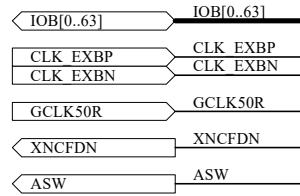

OFF = HIGH:AS
ON = LOW:PS(JTAG)

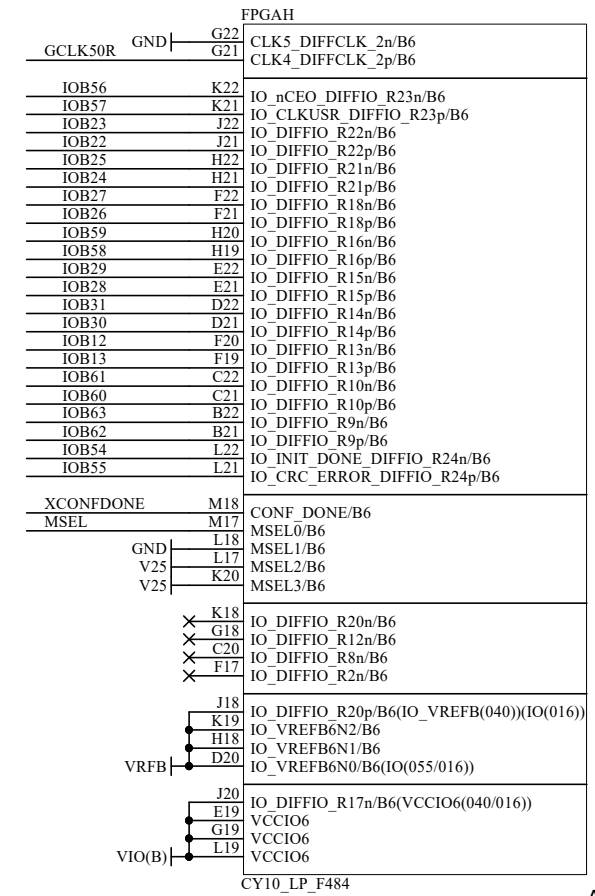
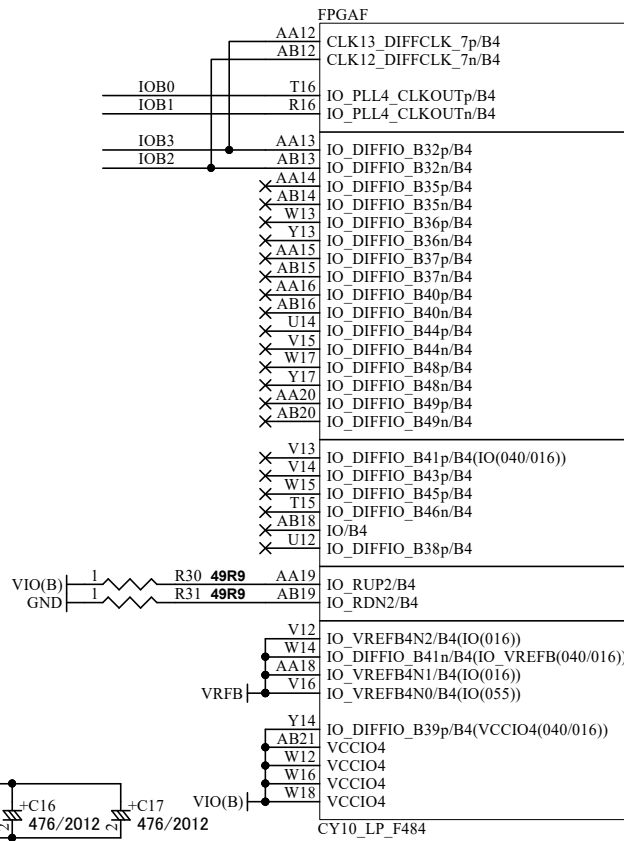
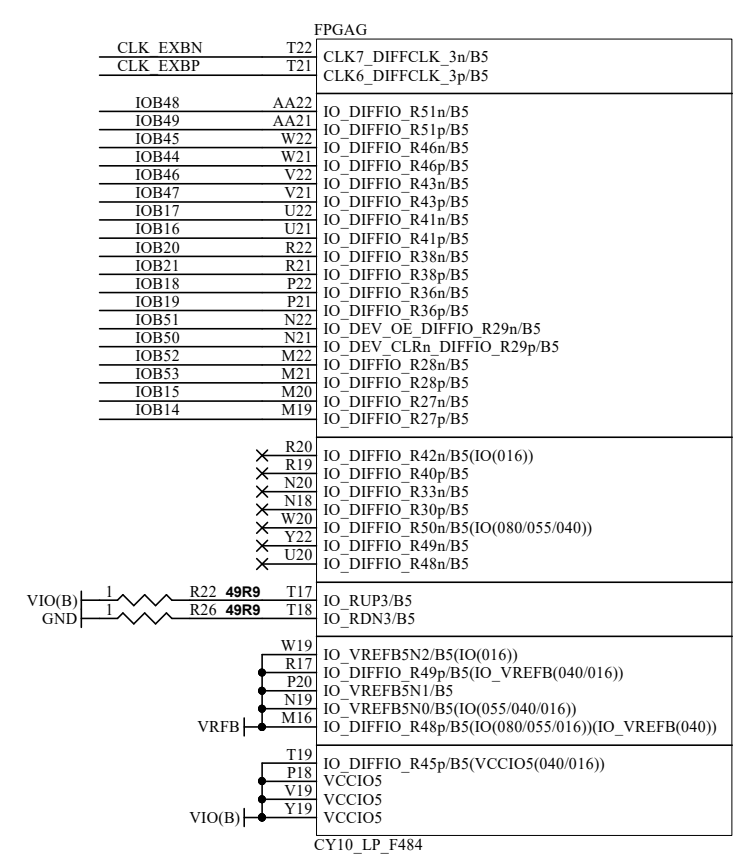
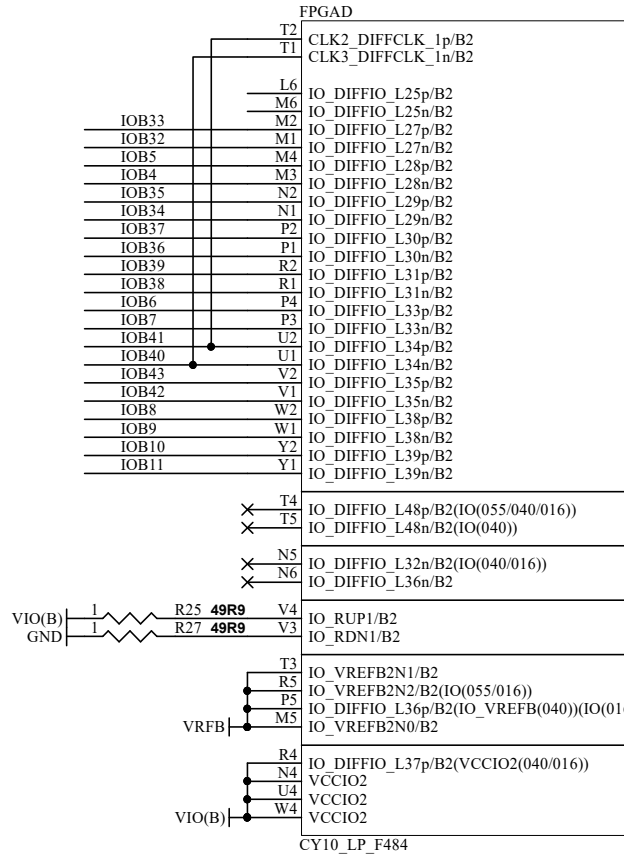
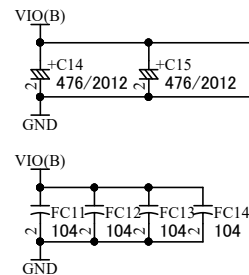
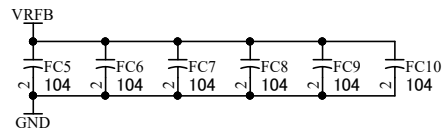
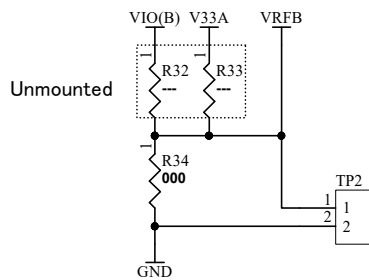
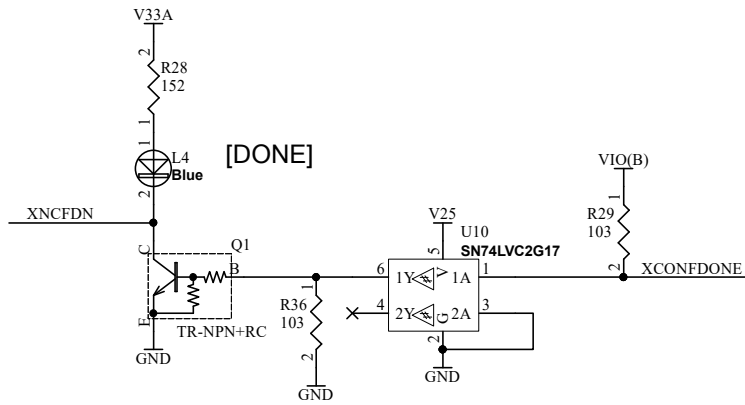

DSN:	TITLE: Intel Cyclone 10 LP F484 FPGA Board
DOC. No:	ACM-114
FILE: IOB.SchDoc	DATE: 2018/01/11 9:45:07
Sheet:	4 / 4

ACM114R1-SCH-A.pdf