

	2010/10/18		
	HuMANDATA LTD. OSAKA JAPAN www.hdl.co.jp/en/(Global) www.hdl.co.jp/(Japan)	Altera CycloneIII F484 FPGA board	
Date: 18-Oct-2010	16:33:06	File: FPGA1.sch	Sheet 2 of 3
		DOC. No. ACM-105	B1

V12 V12A
 V124 V12A
 V33A V33A
 V33B V33B
 GND GND

IOB(0..63) IOB(0..63)

CLK2 CLK2
 CLK3 CLK3
 CLKA CLKA
 CLKB CLKB

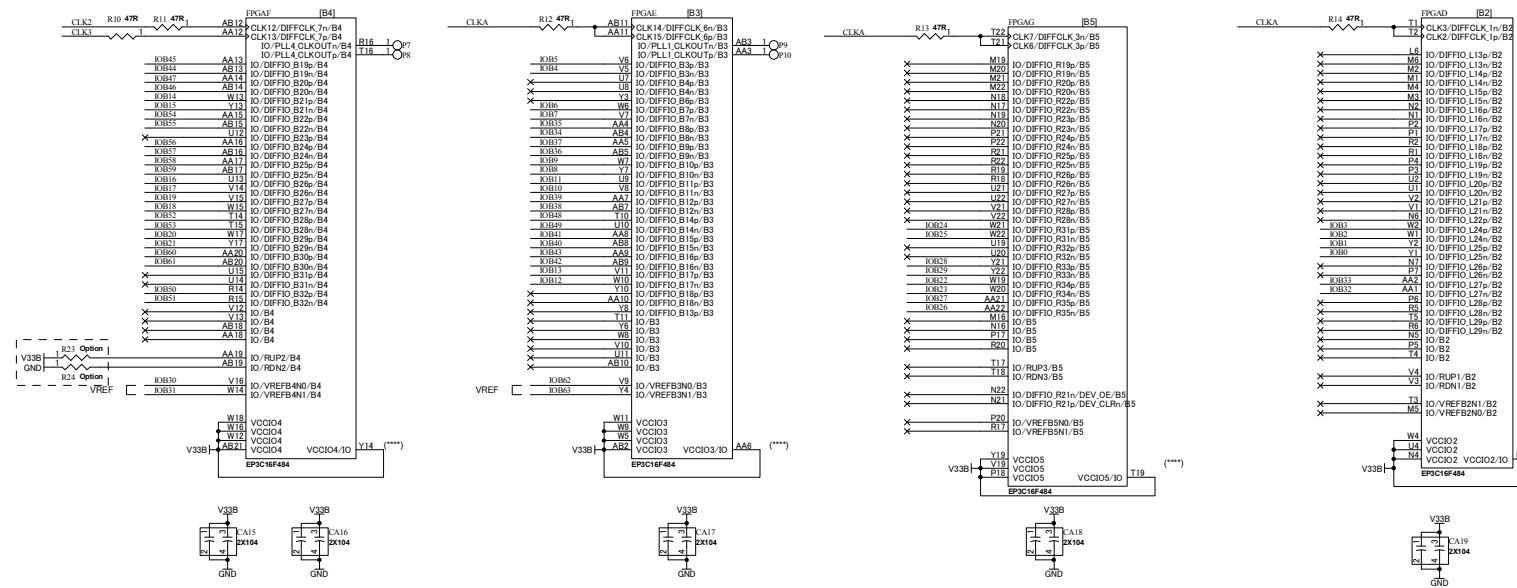

(****) These pins are connected to VCCIO. You need to set them as INPUT.

	2010/10/18	Altera CycloneIII F484 FPGA board		B1
	HuMANDATA LTD. OSAKA JAPAN www.hdl.co.jp/en/ (Global) www.hdl.co.jp/ (Japan)			
Date: 18-Oct-2010	16:33:06	File: FPGA2.sch	Sheet 3 of 3	