

[POWER]

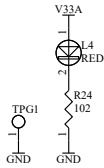

CNA	
V33CNA	3V3
V50CN	5V
GND	5V
GND	5
GND	6
IOA0	7
IOA1	8
IOA2	9
IOA3	10
IOA4	11
IOA5	12
IOA6	13
IOA7	14
GND	15
GND	16
IOA8	17
IOA9	18
IOA10	19
IOA11	20
IOA12	21
IOA13	22
IOA14	23
IOA15	24
GND	25
GND	26
IOA16	27
IOA17	28
IOA18	29
IOA19	30
IOA20	31
IOA21	32
IOA22	33
IOA23	34
GND	35
GND	36
IOA24	37
IOA25	38
IOA26	39
IOA27	40
IOA28	41
IOA29	42
IOA30	43
IOA31	44
GND	45
GND	46
IOA32	47
IOA33	48
IOA34	49
IOA35	50
IOA36	51
IOA37	52
IOA38	53
IOA39	54
GND	55
GND	56
IOA40	57
IOA41	58
IOA42	59
IOA43	60
IOA44	61
IOA45	62
IOA46	63
IOA47	64
IOA48	65
IOA49	66

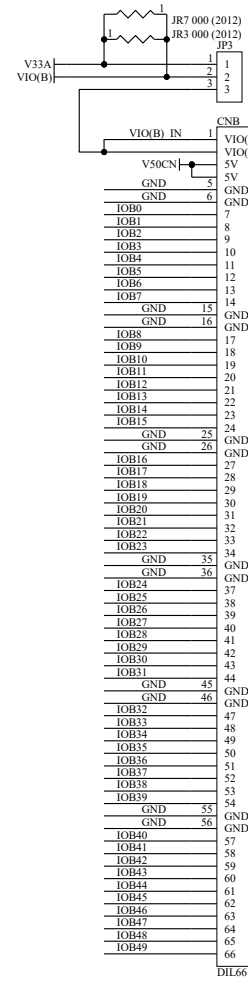

CNB	
V50CN	5V
GND	5
GND	6
IOB0	7
IOB1	8
IOB2	9
IOB3	10
IOB4	11
IOB5	12
IOB6	13
IOB7	14
GND	15
GND	16
IOB8	17
IOB9	18
IOB10	19
IOB11	20
IOB12	21
IOB13	22
IOB14	23
IOB15	24
GND	25
GND	26
IOB16	27
IOB17	28
IOB18	29
IOB19	30
IOB20	31
IOB21	32
IOB22	33
IOB23	34
GND	35
GND	36
IOB24	37
IOB25	38
IOB26	39
IOB27	40
IOB28	41
IOB29	42
IOB30	43
IOB31	44
GND	45
GND	46
IOB32	47
IOB33	48
IOB34	49
IOB35	50
IOB36	51
IOB37	52
IOB38	53
IOB39	54
GND	55
GND	56
IOB40	57
IOB41	58
IOB42	59
IOB43	60
IOB44	61
IOB45	62
IOB46	63
IOB47	64
IOB48	65
IOB49	66

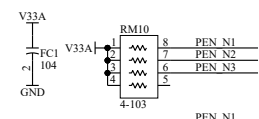
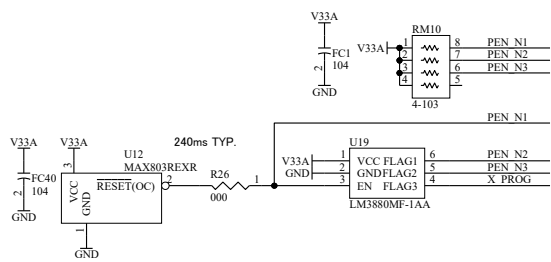
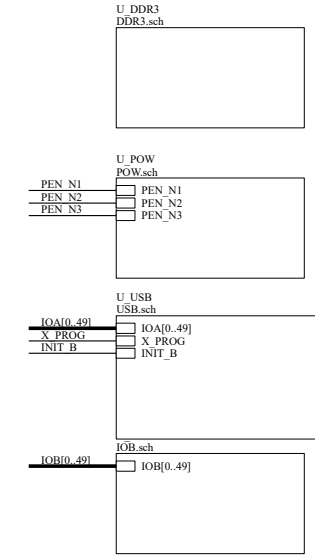

EDX009R3-SCH-D2.pdf

HUMAN DATA
 HUMAN DATA LTD.
www.hdl.co.jp/ (Japan)
www2.hdl.co.jp/en/ (Global)

DSN:	TITLE: KINTEX-7 + FT600 FBG484 USB-FPGA board	D2
DOC. No:	EDX-009	
FILE: EDX009D.sch	DATE: 2022/06/15 16:00:13	Sheet: 1 / 6

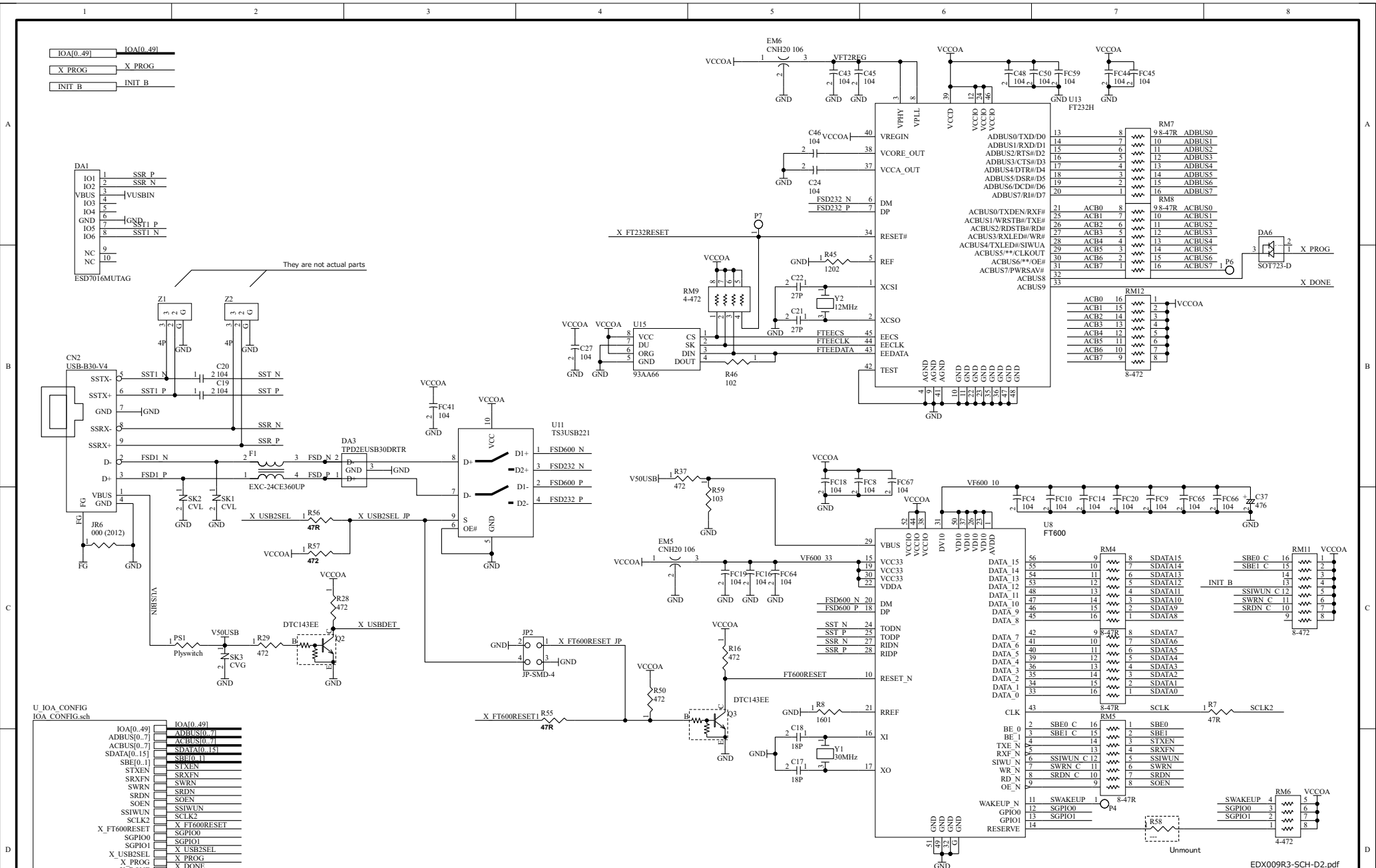

HUMAN DATA
 HUMAN DATA LTD.
www.hdl.co.jp/ (Japan)
www2.hdl.co.jp/en/ (Global)

DSN:	TITLE: KINTEX-7 + FT600 FPG484 USB-FPGA board
DOC. No:	EDX-009
FILE: USB.sch	DATE: 2022/06/15 16:00:13
Sheet: 2 / 6	

D2

IOB[0..49]

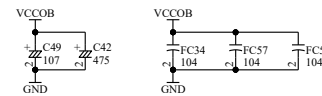
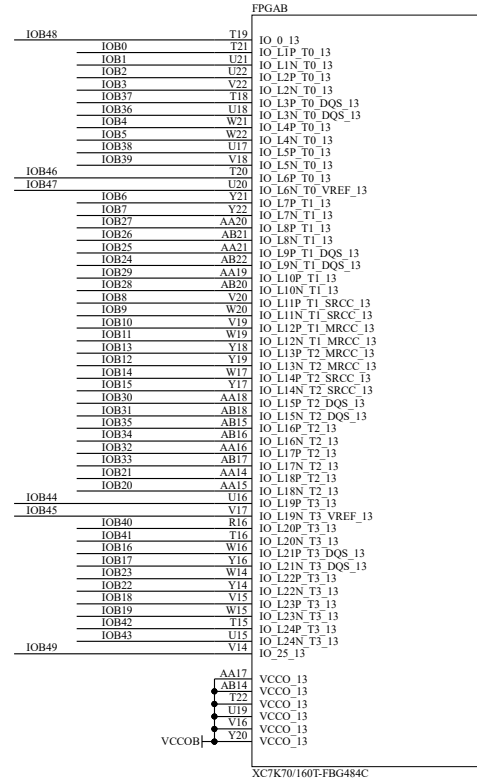
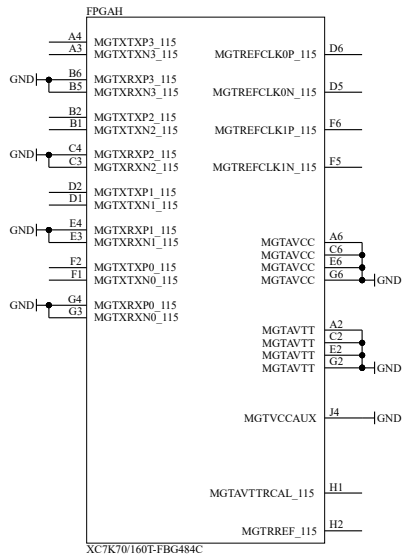

BANK Group B

HUMAN DATA
 HUMAN DATA LTD.
[www.hdl.co.jp/ \(Japan\)](http://www.hdl.co.jp/)
[www2.hdl.co.jp/en/ \(Global\)](http://www2.hdl.co.jp/en/)

DSN:	TITLE: KINTEX-7 + FT600 FBG484 USB-FPGA board	D2
DOC. No:	EDX-009	
FILE: IOB.sch	DATE: 2022/06/15 16:00:13	Sheet: 4 / 6

EDX009R3-SCH-D2.pdf

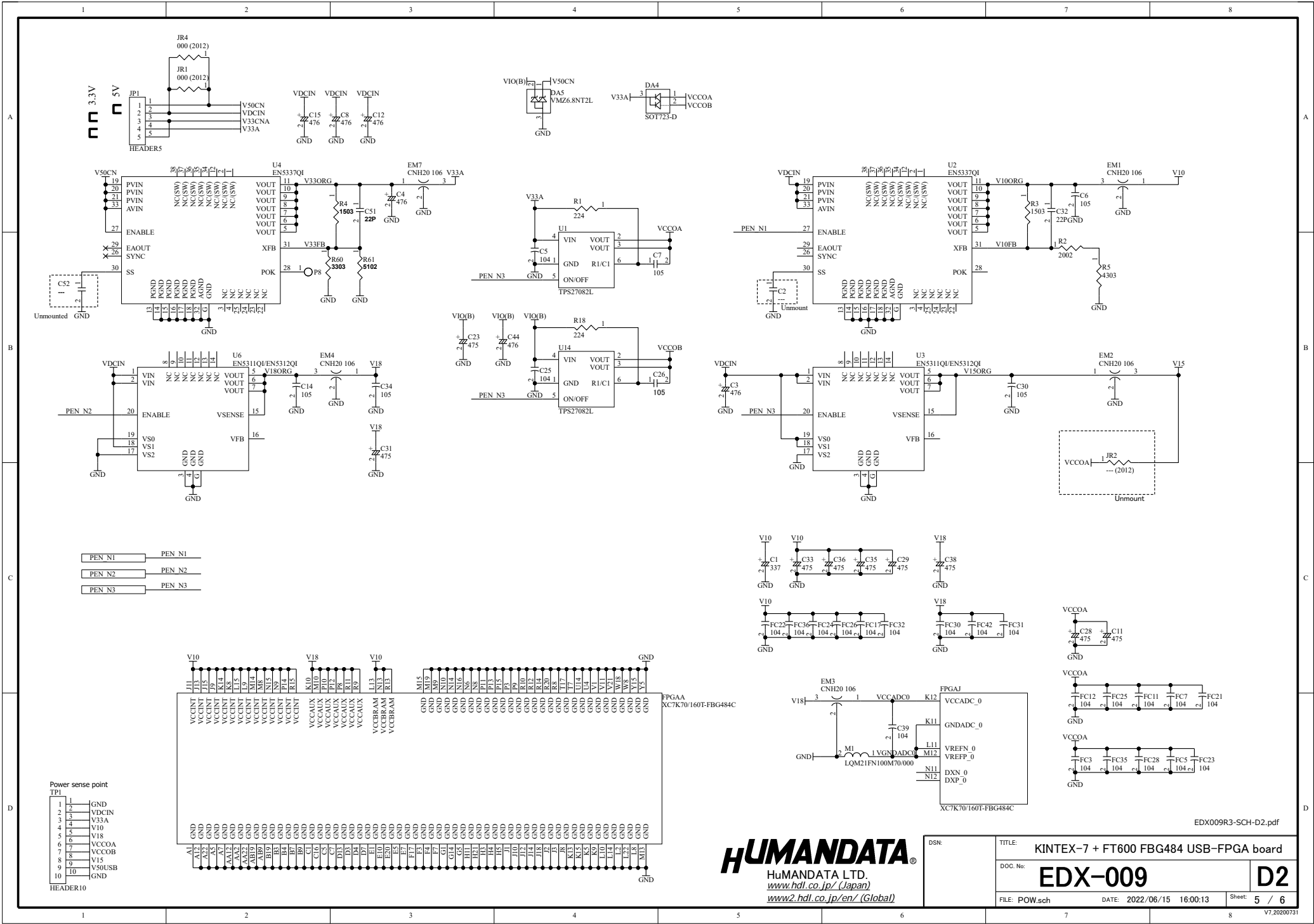

Power sense point TP1

1	GND
2	VDCIN
3	V33A
4	V10
5	V18
6	VCCOA
7	VCCOB
8	V15
9	V50USB
10	GND

HEADER10

HUMAN DATA
 HUMAN DATA LTD.
www.hdl.co.jp/ (Japan)
www2.hdl.co.jp/en/ (Global)

DSN:	TITLE: KINTEX-7 + FT600 FBG484 USB-FPGA board
DOC. No:	EDX-009
FILE: POW.sch	DATE: 2022/06/15 16:00:13
Sheet:	5 / 6

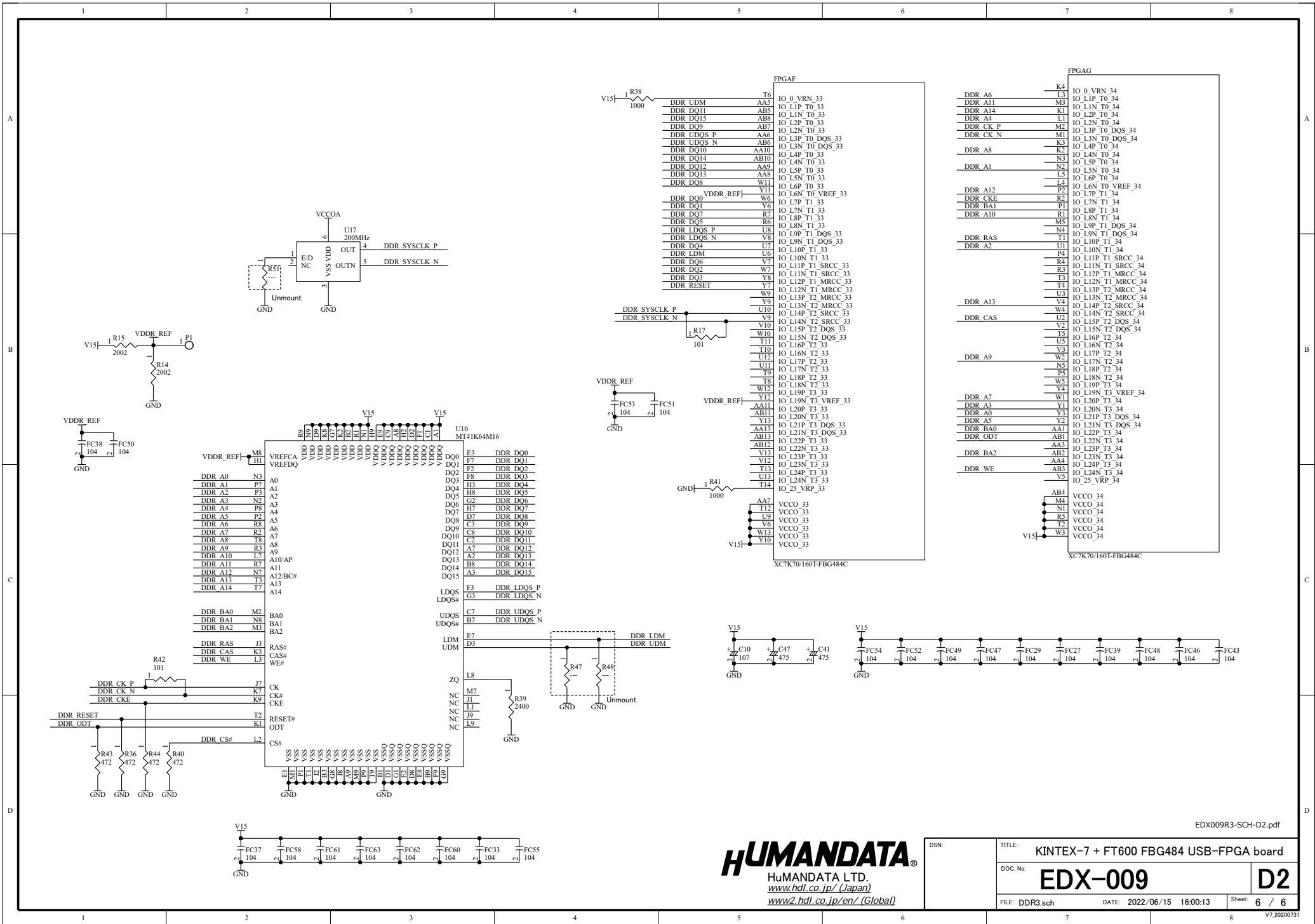

EDX009R3-SCH-D2.pdf

HUMAN DATA
 HUMAN DATA LTD.
[www.hdl.co.jp/ \(Japan\)](http://www.hdl.co.jp/)
[www2.hdl.co.jp/en/ \(Global\)](http://www2.hdl.co.jp/en/)

DSN:	TITLE: KINTEX-7 + FT600 FBG484 USB-FPGA board	D2
DOC. No:	EDX-009	
FILE: DDR3.sch	DATE: 2022/06/15 16:00:13	Sheet: 6 / 6