

[POWER]

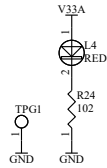

| CNA    |     |
|--------|-----|
| V33CNA | 3V3 |
| V50CN  | 5V  |
| GND    | 5V  |
| GND    | GND |
| IOA0   | 7   |
| IOA1   | 8   |
| IOA2   | 9   |
| IOA3   | 10  |
| IOA4   | 11  |
| IOA5   | 12  |
| IOA6   | 13  |
| IOA7   | 14  |
| GND    | 15  |
| GND    | 16  |
| IOA8   | 17  |
| IOA9   | 18  |
| IOA10  | 19  |
| IOA11  | 20  |
| IOA12  | 21  |
| IOA13  | 22  |
| IOA14  | 23  |
| IOA15  | 24  |
| GND    | 25  |
| GND    | 26  |
| IOA16  | 27  |
| IOA17  | 28  |
| IOA18  | 29  |
| IOA19  | 30  |
| IOA20  | 31  |
| IOA21  | 32  |
| IOA22  | 33  |
| IOA23  | 34  |
| GND    | 35  |
| GND    | 36  |
| IOA24  | 37  |
| IOA25  | 38  |
| IOA26  | 39  |
| IOA27  | 40  |
| IOA28  | 41  |
| IOA29  | 42  |
| IOA30  | 43  |
| IOA31  | 44  |
| GND    | 45  |
| GND    | 46  |
| IOA32  | 47  |
| IOA33  | 48  |
| IOA34  | 49  |
| IOA35  | 50  |
| IOA36  | 51  |
| IOA37  | 52  |
| IOA38  | 53  |
| IOA39  | 54  |
| GND    | 55  |
| GND    | 56  |
| IOA40  | 57  |
| IOA41  | 58  |
| IOA42  | 59  |
| IOA43  | 60  |
| IOA44  | 61  |
| IOA45  | 62  |
| IOA46  | 63  |
| IOA47  | 64  |
| IOA48  | 65  |
| IOA49  | 66  |

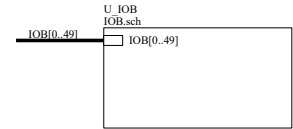
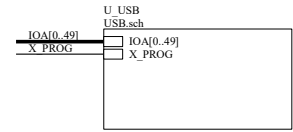
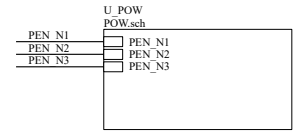
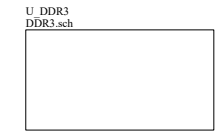
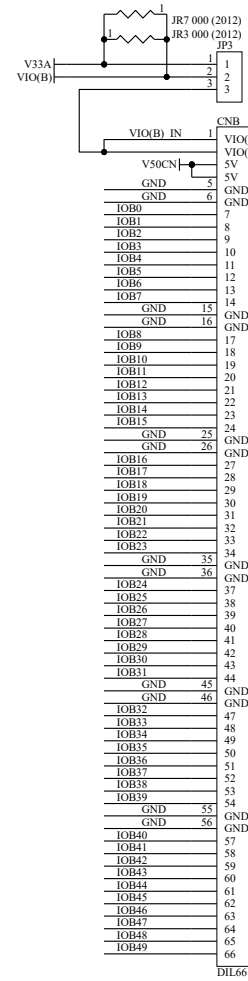

EDX009R3-SCH-C3.pdf

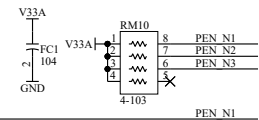
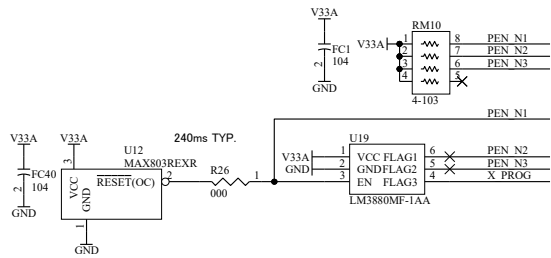

**HUMAN DATA**  
 HUMAN DATA LTD.  
[www.hdl.co.jp/ \(Japan\)](http://www.hdl.co.jp/)  
[www2.hdl.co.jp/en/ \(Global\)](http://www2.hdl.co.jp/en/)

|                   |   |              |
|-------------------|---|--------------|
| DSN:              | TITLE: KINTEX-7 + FT600 FBG484 USB-FPGA board | <b>C3</b>    |
| DOC. No:          | <b>EDX-009</b>                                |              |
| FILE: EDX009C.sch | DATE: 2020/11/24 8:57:43                      | Sheet: 1 / 6 |

A

A

B

B

C

C

D

D

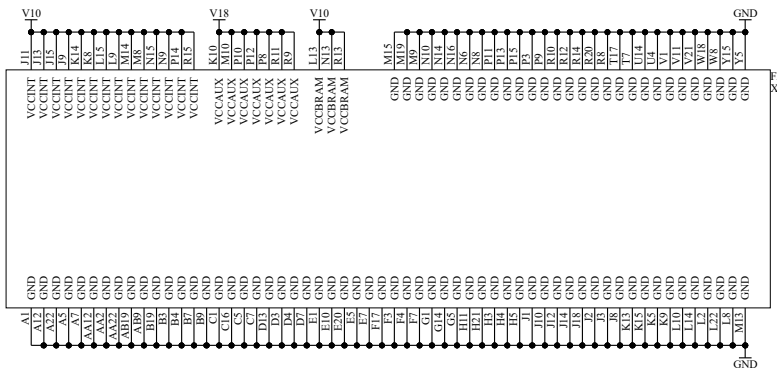
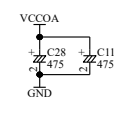
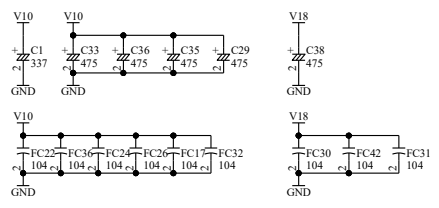
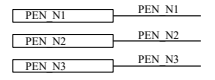
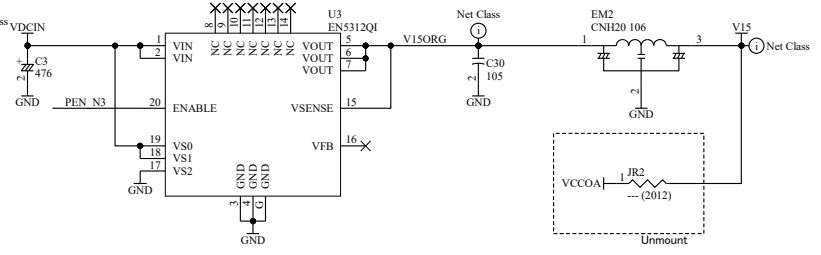
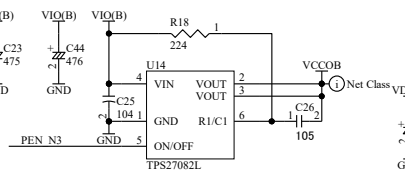
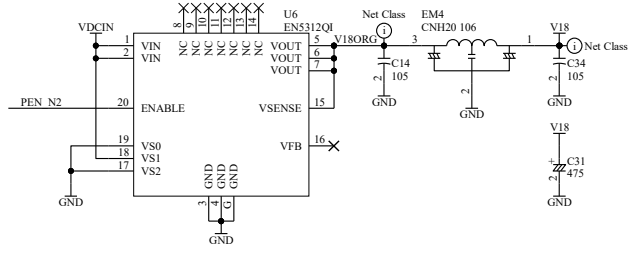
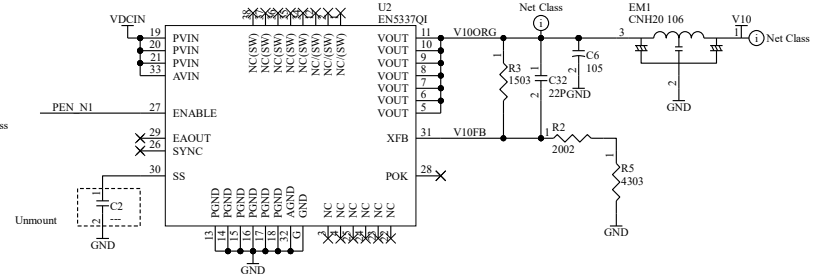
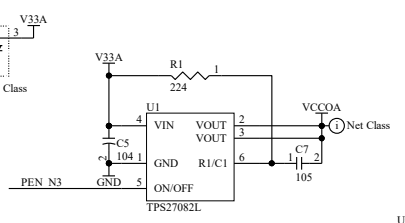
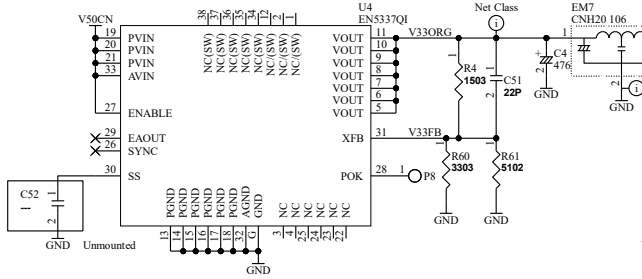
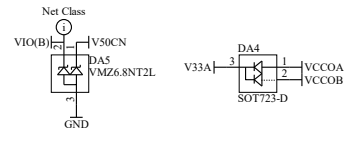
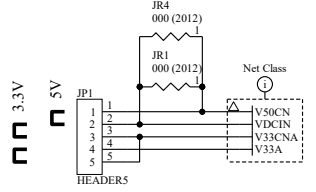

FPGA XC7K70/160T-FBG484C

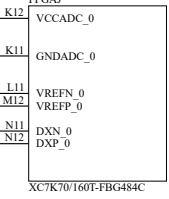

XC7K70/160T-FBG484C

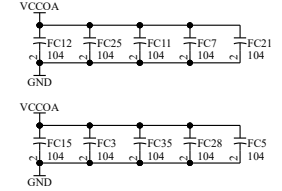

Power sense point TP1

|    |        |
|----|--------|
| 1  | GND    |
| 2  | VDCIN  |
| 3  | V33A   |
| 4  | V10    |
| 5  | V18    |
| 6  | VCCOA  |
| 7  | VCCOB  |
| 8  | V15    |
| 9  | V50USB |
| 10 | GND    |

HEADER10

EDX009R3-SCH-C3.pdf

**HUMAN DATA**  
 HUMAN DATA LTD.  
[www.hdl.co.jp/](http://www.hdl.co.jp/) (Japan)  
[www2.hdl.co.jp/en/](http://www2.hdl.co.jp/en/) (Global)

|               |   |
|---------------|---|
| DSN:          | TITLE: KINTEX-7 + FT600 FBG484 USB-FPGA board |
| DOC. No:      | <b>EDX-009</b>                                |
| FILE: POW.sch | DATE: 2020/11/24 8:57:43                      |
| Sheet:        | <b>2 / 6</b>                                  |

**C3**

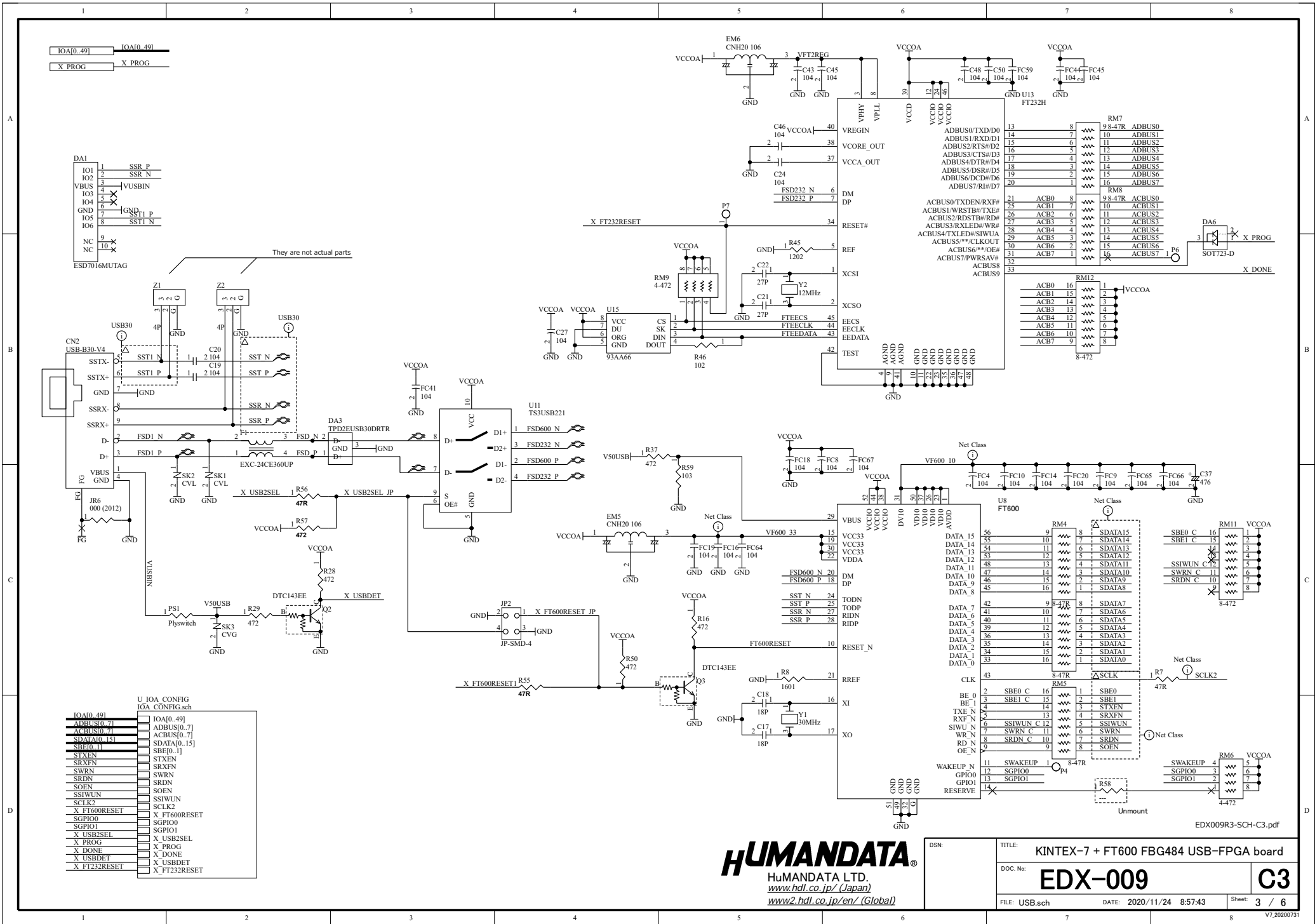

IOA[0..49] IOA[0..49]  
X PROG X PROG

DA1  
IO1 1 SSR\_P  
IO2 2 SSR\_N  
VBUS 3 VUSBIN  
IO3 4  
IO4 5 X  
IO5 6 X  
IO6 7 X  
IO6 8 X  
IO6 9 X  
IO6 10 X  
ESD7016MUTAG

Z1 Z2  
They are not actual parts

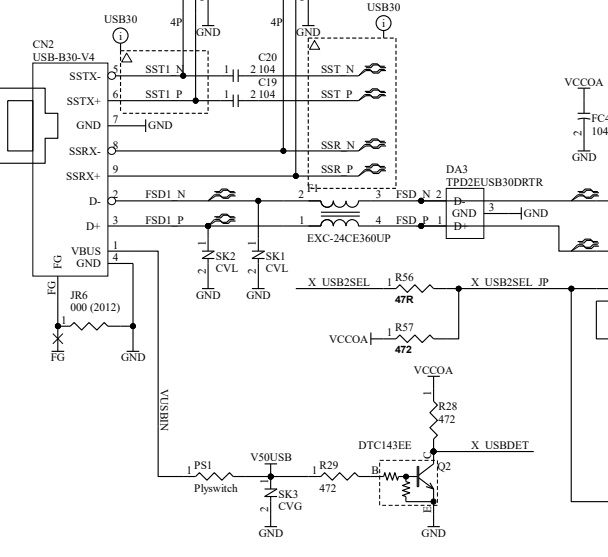

U IOA CONFIG  
IOA CONFIG.sch

|              |              |
|--------------|--------------|
| IOA[0..49]   | IOA[0..49]   |
| ADDR[0..7]   | ADDR[0..7]   |
| ACBUS[0..7]  | ACBUS[0..7]  |
| SDATA[0..15] | SDATA[0..15] |
| SBE[0..1]    | SBE[0..1]    |
| STXEN        | STXEN        |
| SRXFN        | SRXFN        |
| SWRN         | SWRN         |
| SRDN         | SRDN         |
| SOEN         | SOEN         |
| SSIWUN       | SSIWUN       |
| SCLK2        | SCLK2        |
| X FT600RESET | X FT600RESET |
| SGPIO0       | SGPIO0       |
| SGPIOT       | SGPIOT       |
| X USB2SEL    | X USB2SEL    |
| X USBSEL     | X USBSEL     |
| X PROG       | X PROG       |
| X DONE       | X DONE       |
| X USBDET     | X USBDET     |
| X FT232RESET | X FT232RESET |

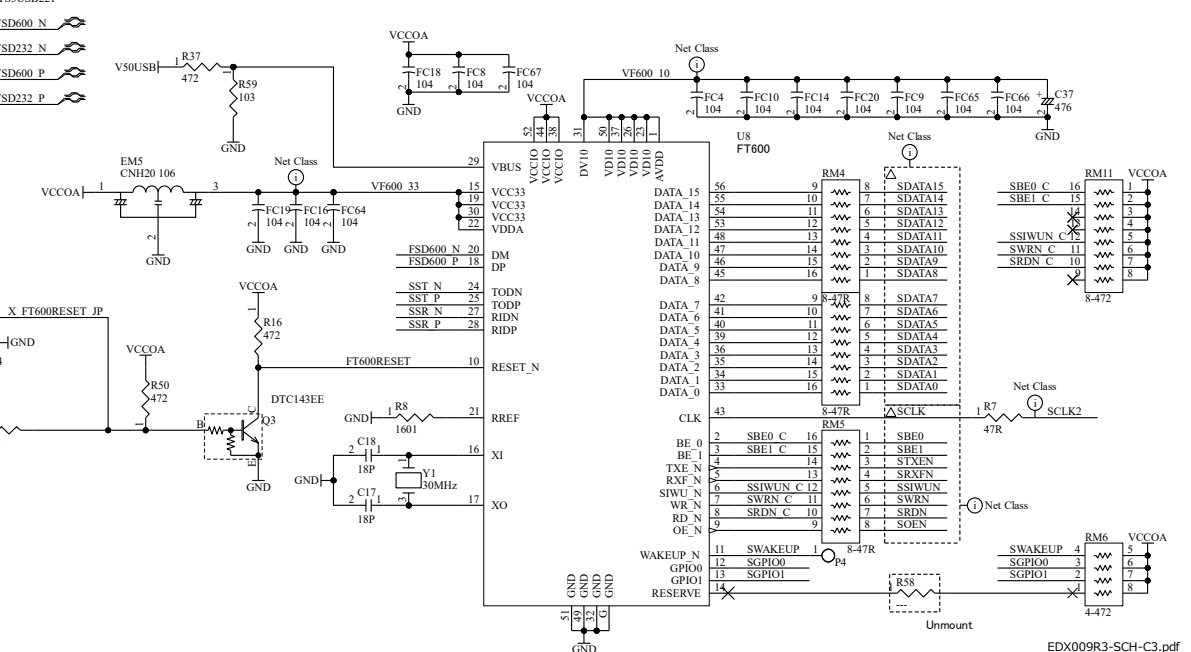
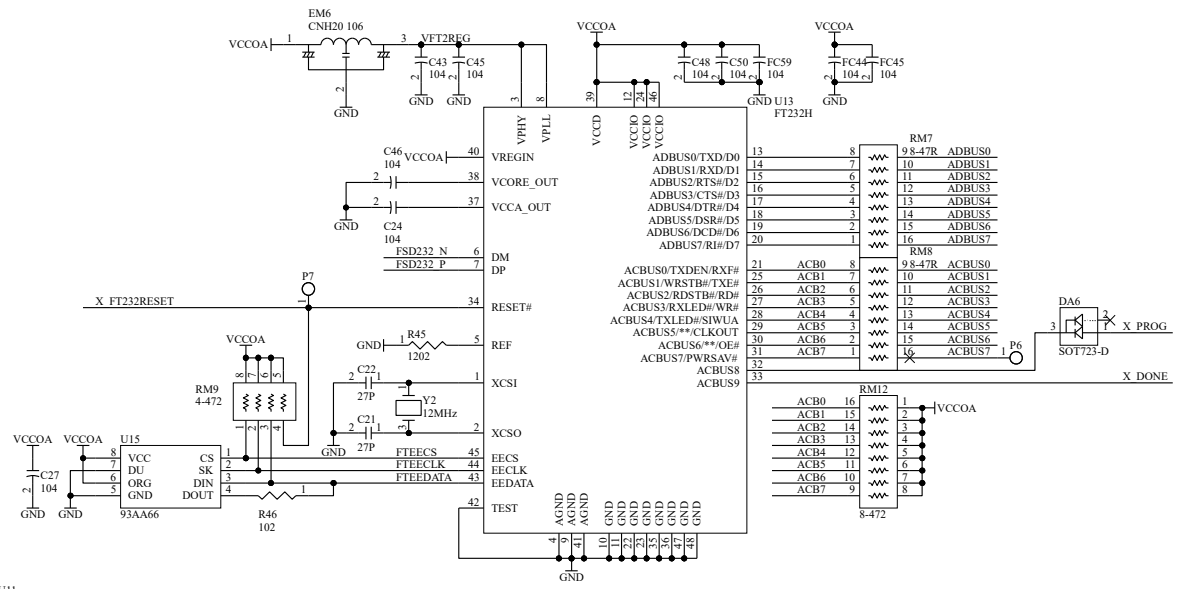

**HUMAN DATA**  
HuMANDATA LTD.  
www.hdl.co.jp/ (Japan)  
www2.hdl.co.jp/en/ (Global)

|               |   |
|---------------|---|
| DSN:          | TITLE: KINTEX-7 + FT600 FBG484 USB-FPGA board |
| DOC. No:      | EDX-009                                       |
| FILE: USB.sch | DATE: 2020/11/24 8:57:43                      |
| Sheet: 3 / 6  | C3  |

# BANK Group A

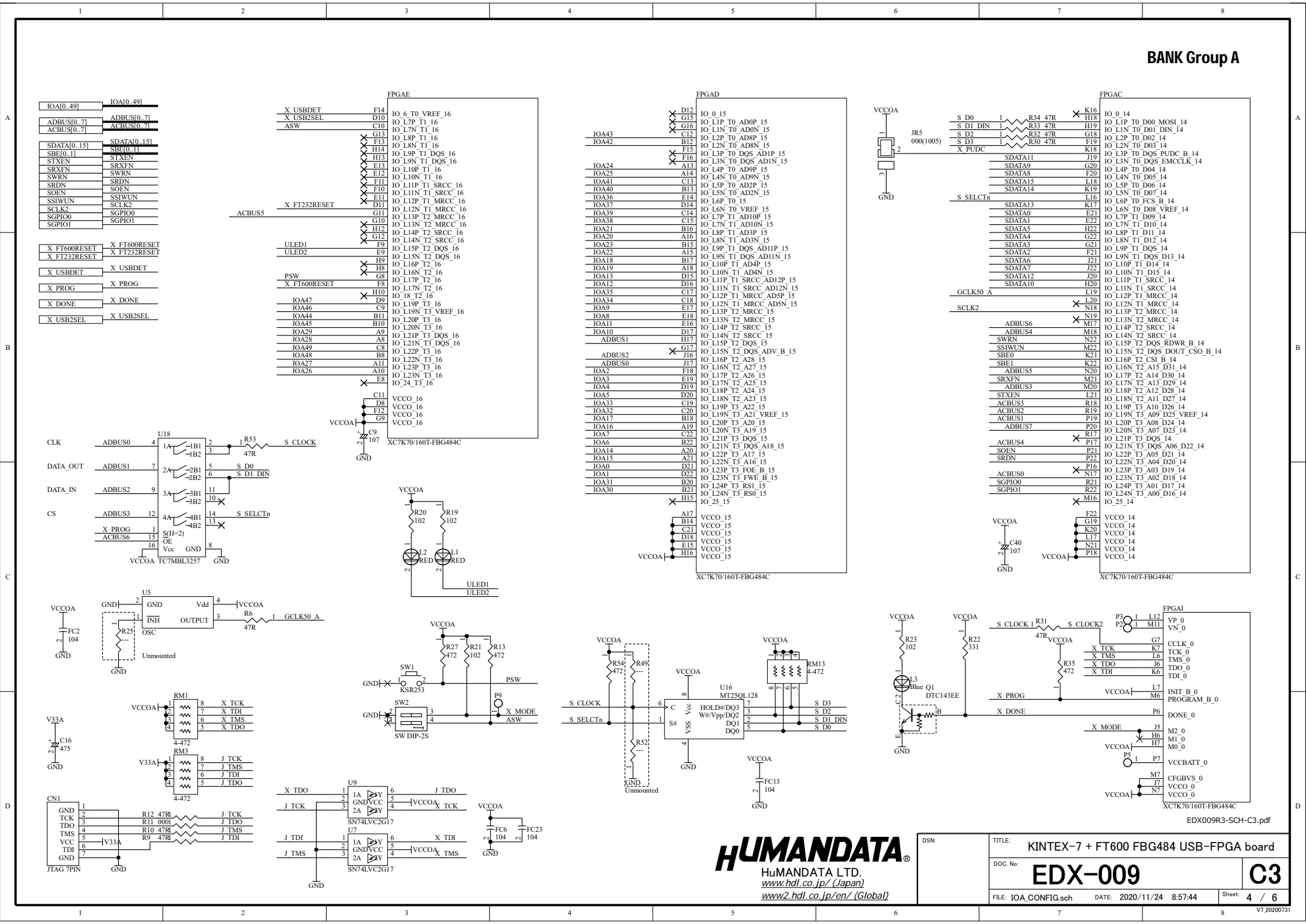

|   |                          |              |
|---|--------------------------|--------------|
| TITLE: KINTEX-7 + FT600 FBG484 USB-FPGA board |                          | <b>C3</b>    |
| DOC. No:                                      | <b>EDX-009</b>           |              |
| FILE: IOA_CONFIG.sch                          | DATE: 2020/11/24 8:57:44 | Sheet: 4 / 6 |

IOB[0..49]

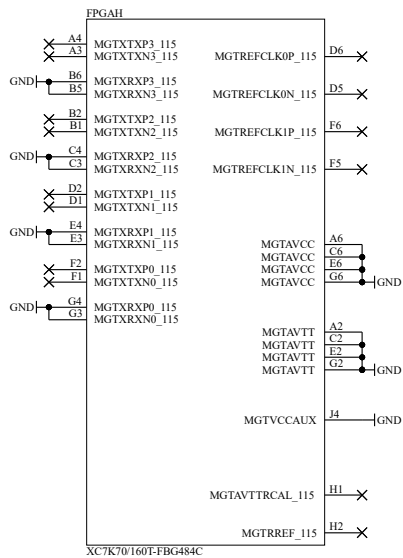

XC7K70/160T-FBG484C

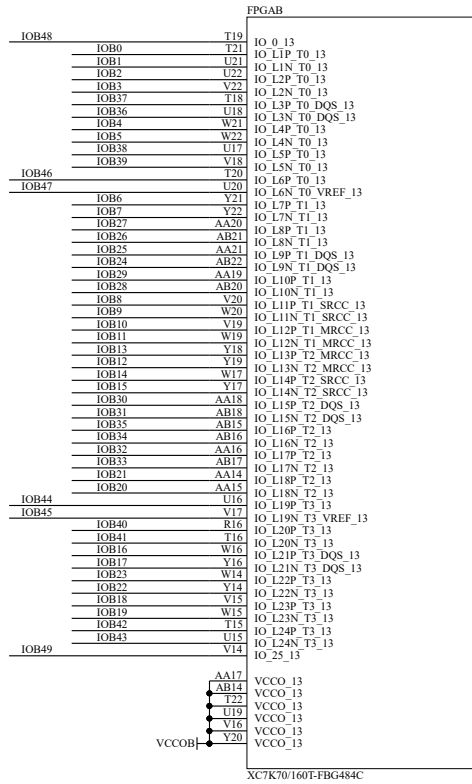

XC7K70/160T-FBG484C

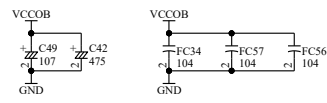

BANK Group B

**HUMAN DATA**  
 HUMAN DATA LTD.  
[www.hdl.co.jp/ \(Japan\)](http://www.hdl.co.jp/)  
[www2.hdl.co.jp/en/ \(Global\)](http://www2.hdl.co.jp/en/ (Global))

|               |   |              |
|---------------|---|--------------|
| DSN:          | TITLE: KINTEX-7 + FT600 FBG484 USB-FPGA board | <b>C3</b>    |
| DOC. No:      | <b>EDX-009</b>                                |              |
| FILE: IOB.sch | DATE: 2020/11/24 8:57:44                      | Sheet: 5 / 6 |

EDX009R3-SCH-C3.pdf

V7\_20200731

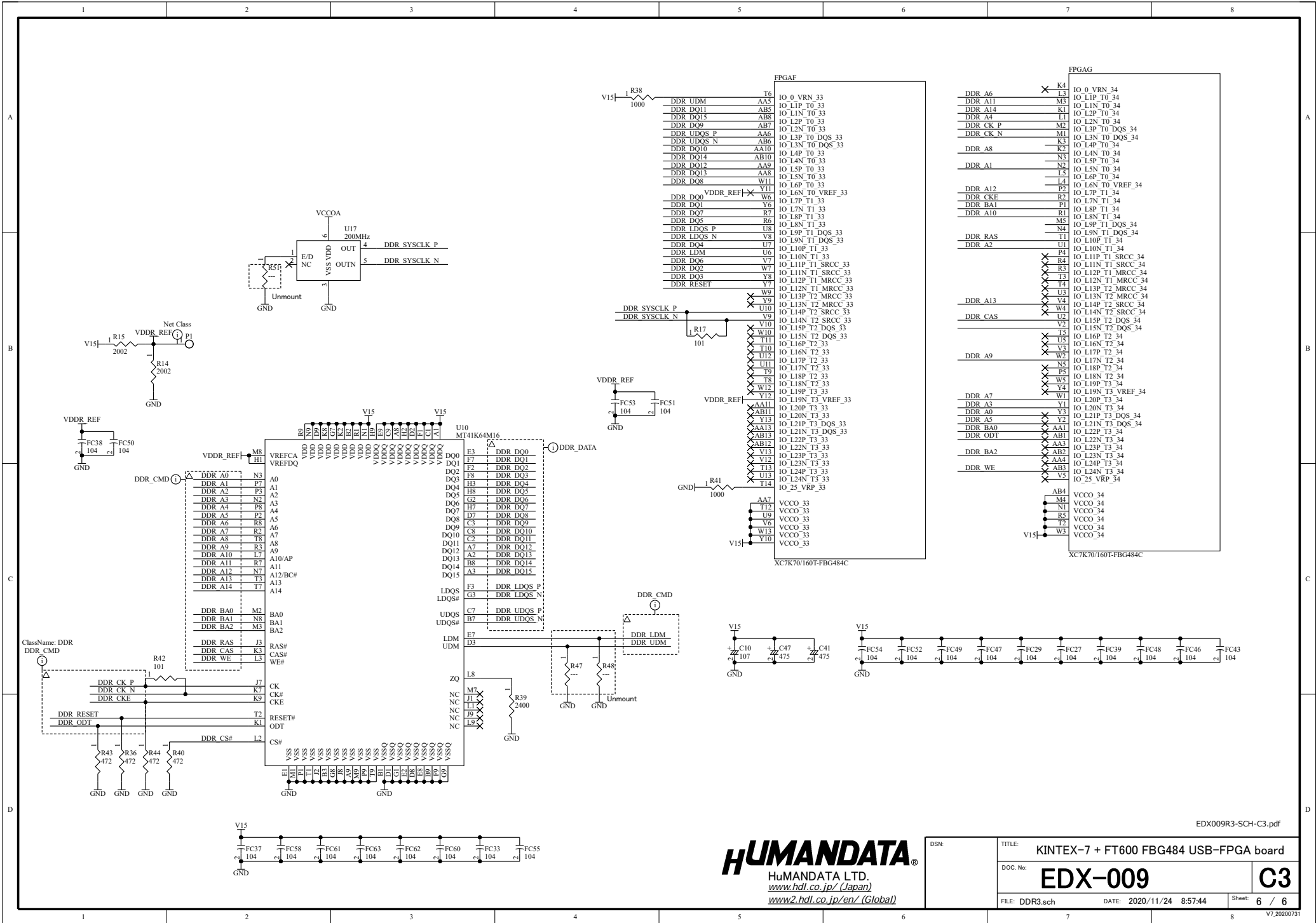

|                |   |
|----------------|---|
| DSN:           | TITLE: KINTEX-7 + FT600 FBG484 USB-FPGA board |
| DOC. No:       | <b>EDX-009</b>                                |
| FILE: DDR3.sch | DATE: 2020/11/24 8:57:44                      |
| Sheet: 6 / 6   | <b>C3</b>                                     |

EDX009R3-SCH-C3.pdf