

[POWER]

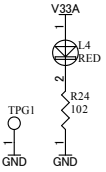

CNA	
3V3	1
3V3	2
5V	3
5V	4
GND	5
GND	6
IOA0	7
IOA1	8
IOA2	9
IOA3	10
IOA4	11
IOA5	12
IOA6	13
IOA7	14
GND	15
GND	16
IOA8	17
IOA9	18
IOA10	19
IOA11	20
IOA12	21
IOA13	22
IOA14	23
IOA15	24
GND	25
GND	26
IOA16	27
IOA17	28
IOA18	29
IOA19	30
IOA20	31
IOA21	32
IOA22	33
IOA23	34
GND	35
GND	36
IOA24	37
IOA25	38
IOA26	39
IOA27	40
IOA28	41
IOA29	42
IOA30	43
IOA31	44
GND	45
GND	46
IOA32	47
IOA33	48
IOA34	49
IOA35	50
IOA36	51
IOA37	52
IOA38	53
IOA39	54
GND	55
GND	56
IOA40	57
IOA41	58
IOA42	59
IOA43	60
IOA44	61
IOA45	62
IOA46	63
IOA47	64
IOA48	65
IOA49	66

CNB	
VIO(B) IN	1
VIO(B)	2
VIO(B)	3
V50CN	5
GND	6
GND	7
IOB0	8
IOB1	9
IOB2	10
IOB3	11
IOB4	12
IOB5	13
IOB6	14
IOB7	15
GND	16
GND	17
IOB8	18
IOB9	19
IOB10	20
IOB11	21
IOB12	22
IOB13	23
IOB14	24
IOB15	25
GND	26
GND	27
IOB16	28
IOB17	29
IOB18	30
IOB19	31
IOB20	32
IOB21	33
IOB22	34
IOB23	35
GND	36
GND	37
IOB24	38
IOB25	39
IOB26	40
IOB27	41
IOB28	42
IOB29	43
IOB30	44
IOB31	45
GND	46
GND	47
IOB32	48
IOB33	49
IOB34	50
IOB35	51
IOB36	52
IOB37	53
IOB38	54
IOB39	55
GND	56
GND	57
IOB40	58
IOB41	59
IOB42	60
IOB43	61
IOB44	62
IOB45	63
IOB46	64
IOB47	65
IOB48	66

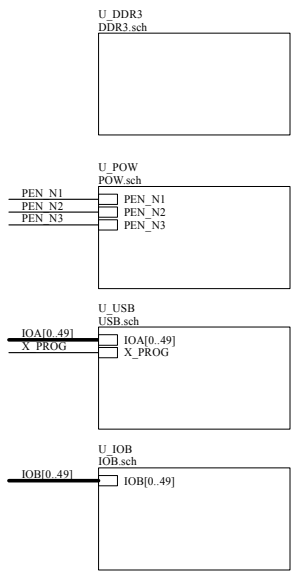

EDX009R2-SCH-C2.pdf



DSN:	TITLE: KINTEX-7 + FT600 FBG484 USB-FPGA board
DOC. No: EDX-009	C2
FILE: EDX009C.sch	DATE: 2019/11/12 17:54:58 Sheet: 1 / 6

A

A

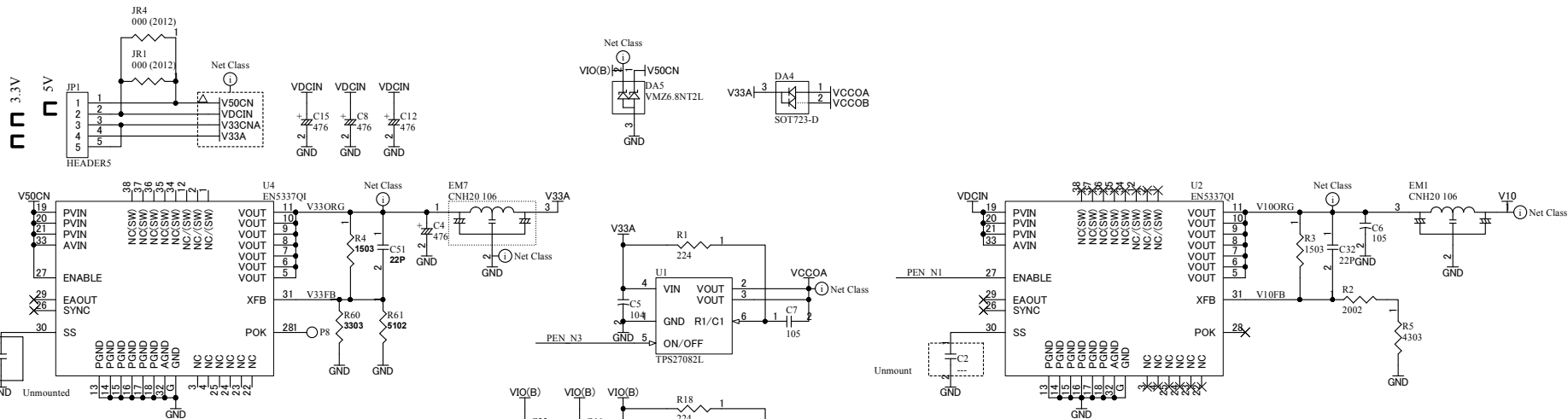

B

B

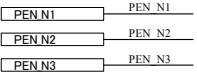
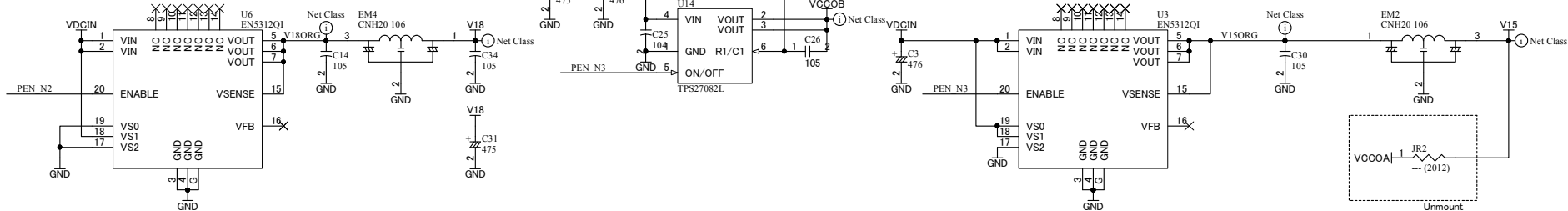

C

C

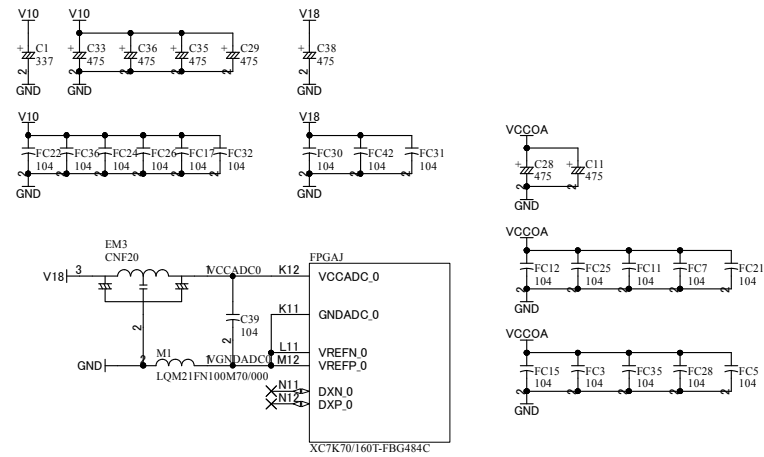

D

D

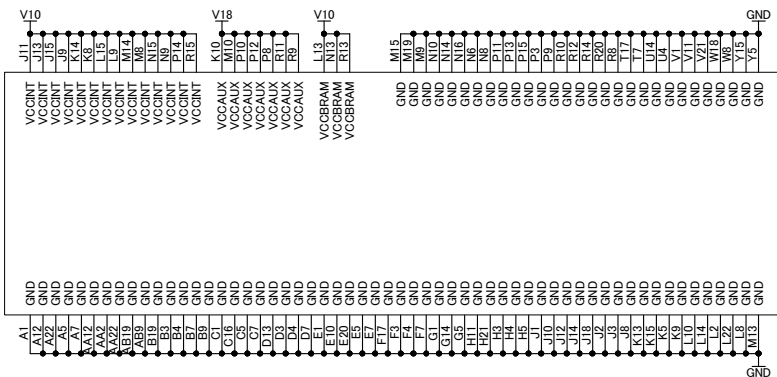
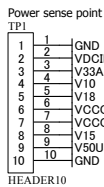

FPGA
XC7K70/160T-FBG484C

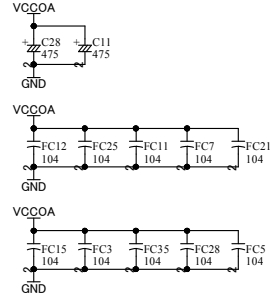
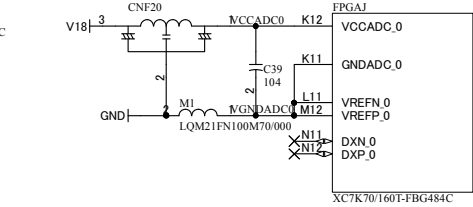

EDX009R2-SCH-C2.pdf

HUMAN DATA
HuMANDATA LTD.
www.hdl.co.jp

DSN:	TITLE: KINTEX-7 + FT600 FBG484 USB-FPGA board
DOC. No:	EDX-009
FILE: POW.sch	DATE: 2019/11/12 17:54:58
	Sheet: 2 / 6

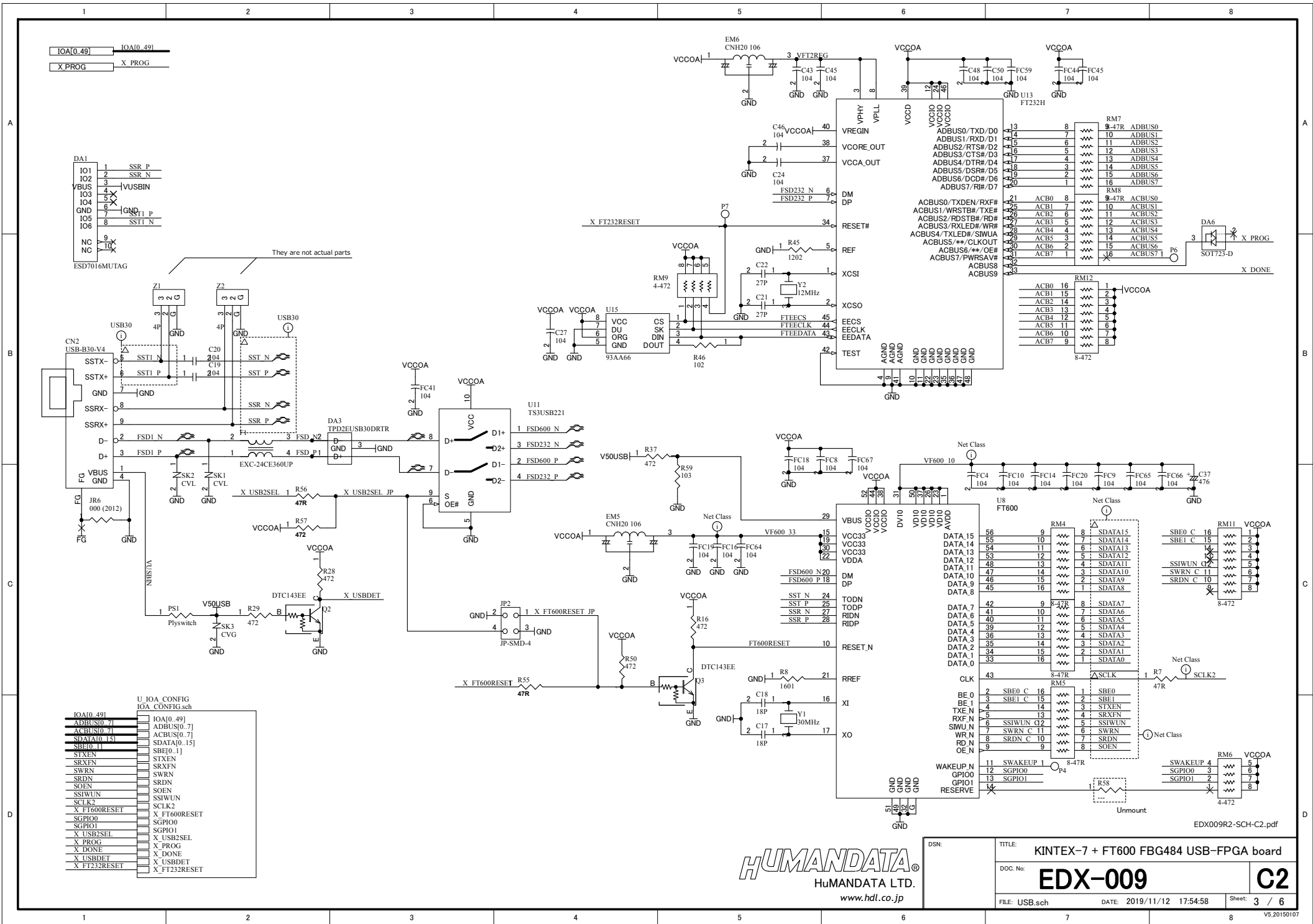

IOA[0..49] X PROG

DA1
IO1 1 SSR P
IO2 2 SSR N
YBUS 3 VUSBIN
IO3 4
IO4 5
GND 6 GND T1 P
IO5 7 SSI1 N
IO6 8
NC 9
NC 10

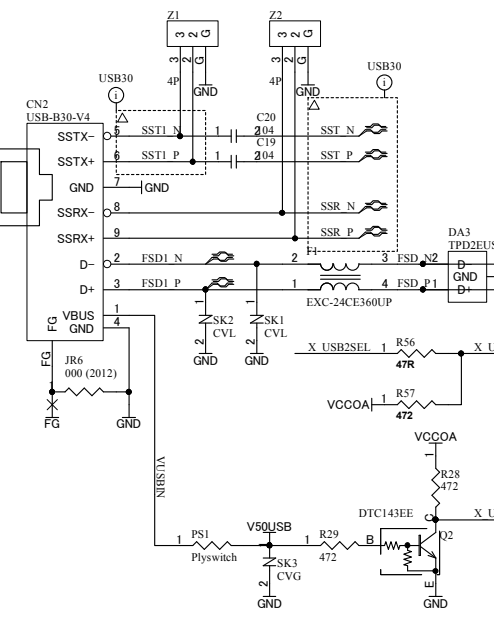

U JOA CONFIG
IOA_CONFIG.sch

IOA[0..49]	IOA[0..49]
ADBUS[0..7]	ADBUS[0..7]
ACBUS[0..7]	ACBUS[0..7]
SDATA[0..15]	SDATA[0..15]
SBE[0..1]	SBE[0..1]
STXEN	STXEN
SRXFN	SRXFN
SWRN	SWRN
SRDN	SRDN
SOEN	SOEN
SSIWUN	SSIWUN
SCLK2	SCLK2
X FT600RESET	X FT600RESET
SGPIO0	SGPIO0
SGPIO1	SGPIO1
X USB2SEL	X USB2SEL
X PROG	X PROG
X DONE	X DONE
X USBDET	X USBDET
X FT232RESET	X FT232RESET

EDX009R2-SCH-C2.pdf

DSN: TITLE: KINTEX-7 + FT600 FBG484 USB-FPGA board

DOC No: EDX-009

FILE: USB.sch DATE: 2019/11/12 17:54:58 Sheet: 3 / 6



IOA[0..49]	IOA[0..49]
ADBUS[0..7]	ADBUS[0..7]
ACBUS[0..7]	ACBUS[0..7]
SDATA[0..15]	SDATA[0..15]
SBE[0..1]	SBE[0..1]
SRXEN	SRXEN
SRXFN	SRXFN
SWRN	SWRN
SRDN	SRDN
SOEN	SOEN
SSIWUN	SSIWUN
SCLK2	SGPIO0
SGPIO0	SGPIO1

X FT600RESET	X FT232RESET
X FT600RESET	X FT232RESET
X USBDET	X USBDET
X PROG	X PROG
X DONE	X DONE
X USB2SEL	X USB2SEL

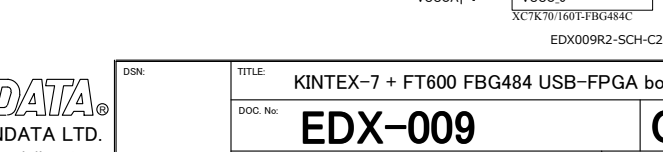
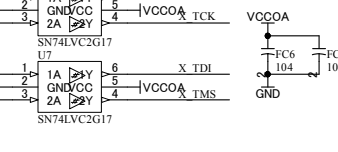
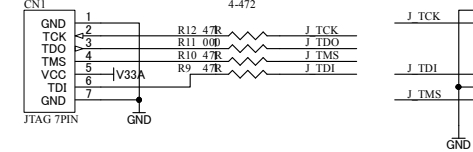
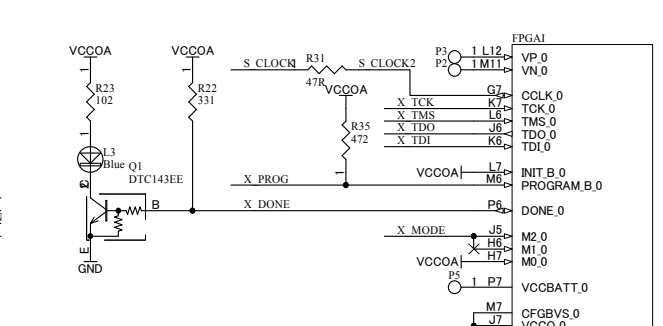
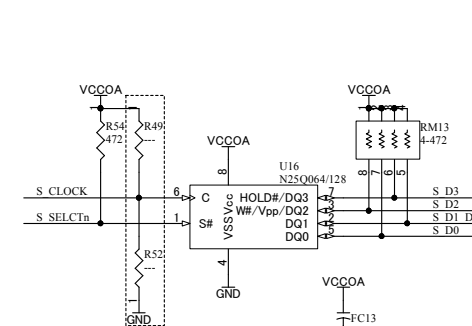
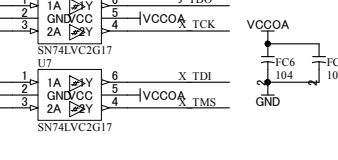
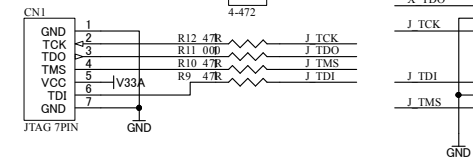
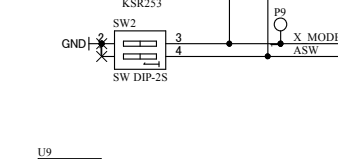
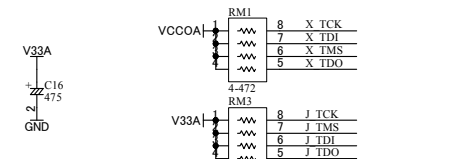
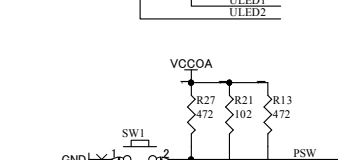
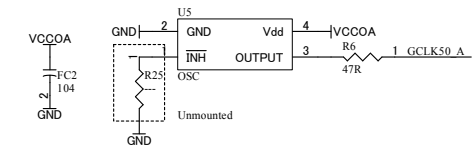
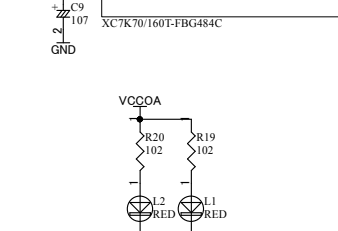
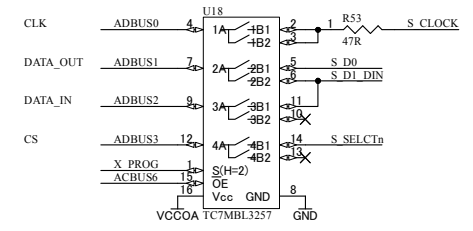
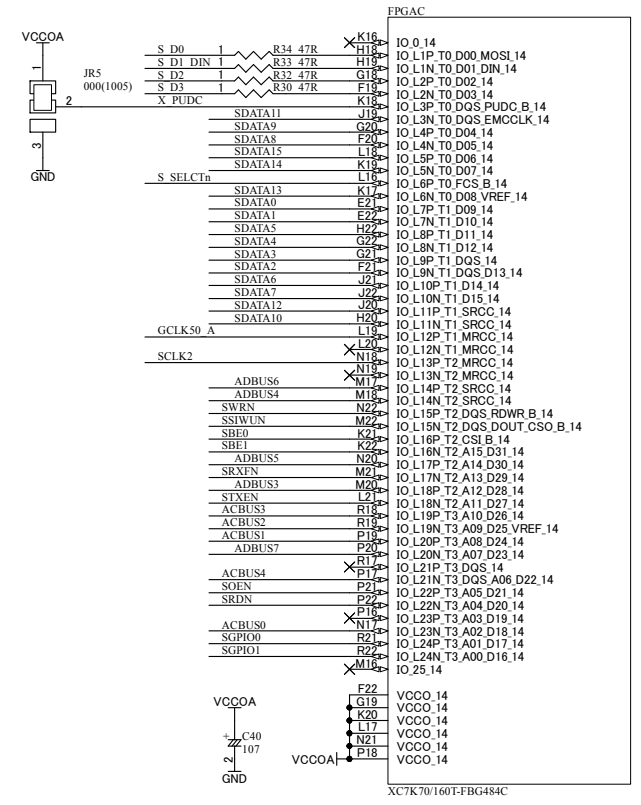
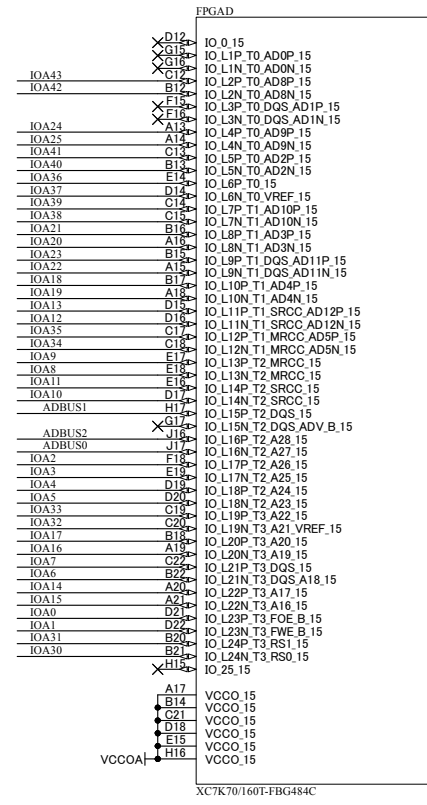
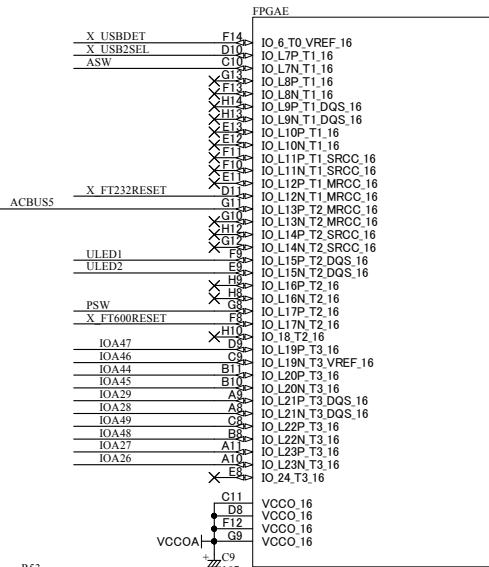

DSN:	TITLE: KINTEX-7 + FT600 FBG484 USB-FPGA board
DOC. No:	EDX-009
FILE: IOA_CONFIG.sch	DATE: 2019/11/12 17:54:59
Sheet: 4 / 6	

IOB[0..49]

1 2 3 4 5 6 7 8

A
B
C
D

A
B
C
D

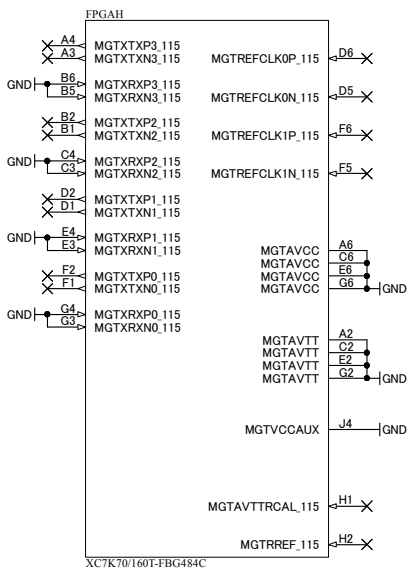

XC7K70/160T-FBG484C

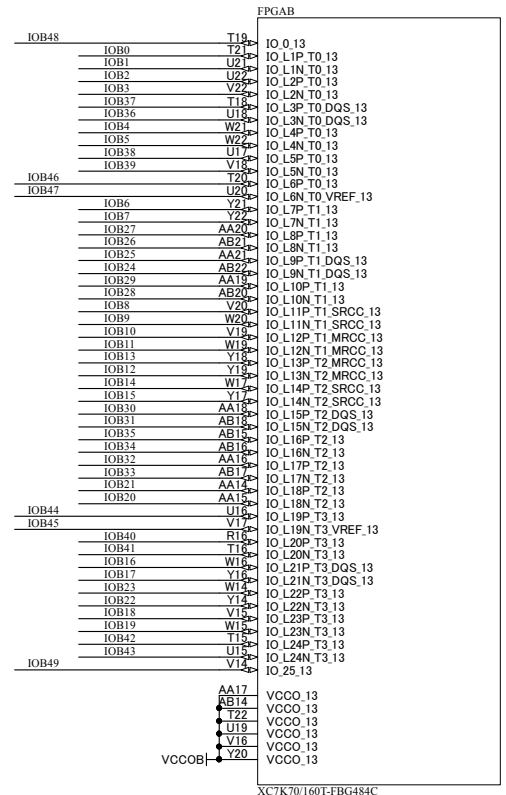

XC7K70/160T-FBG484C

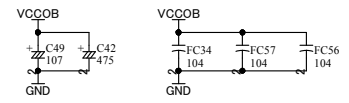

DSN:	TITLE: KINTEX-7 + FT600 FBG484 USB-FPGA board
DOC. No: EDX-009	C2
FILE: IOB.sch	DATE: 2019/11/12 17:54:59
Sheet: 5 / 6	Sheet: 5 / 6

1 2 3 4 5 6 7 8

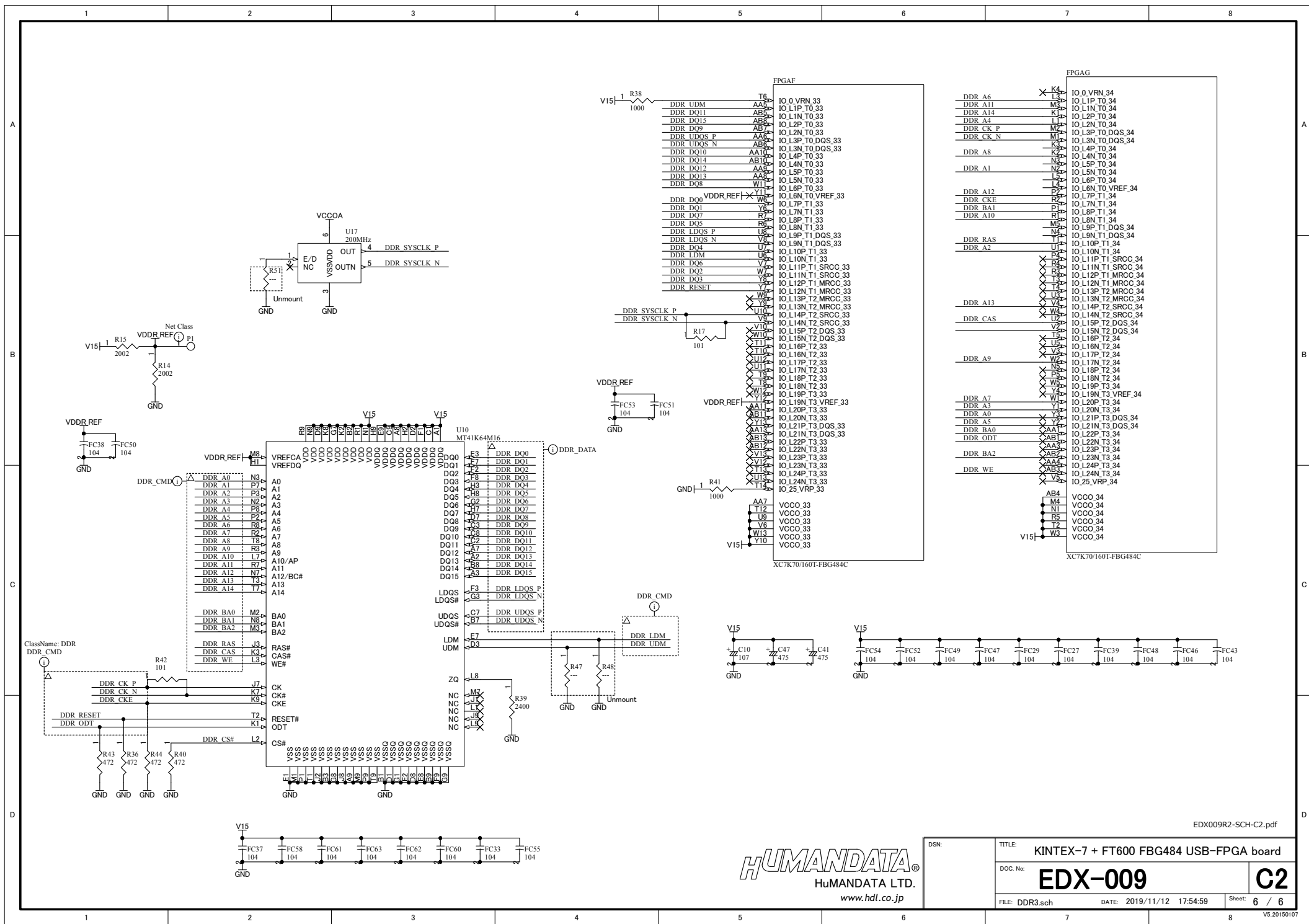

EDX009R2-SCH-C2.pdf



DSN:	TITLE: KINTEX-7 + FT600 FBG484 USB-FPGA board
DOC. No: EDX-009	C2
FILE: DDR3.sch	DATE: 2019/11/12 17:54:59
	Sheet: 6 / 6