

EDA009R1-SCH-D1.pdf

**HUMAN DATA**  
 HuMANDATA LTD.  
[www.hdl.co.jp/ \(Japan\)](http://www.hdl.co.jp/)  
[www2.hdl.co.jp/en/ \(Global\)](http://www2.hdl.co.jp/en/ (Global))

DSN:	TITLE: Altera CycloneV USB-FPGA board	D1
DOC. No.:	<b>EDA-009</b>	
FILE: EDA009D.sch	DATE: 2020/07/01 16:22:56	Sheet 1 / 5

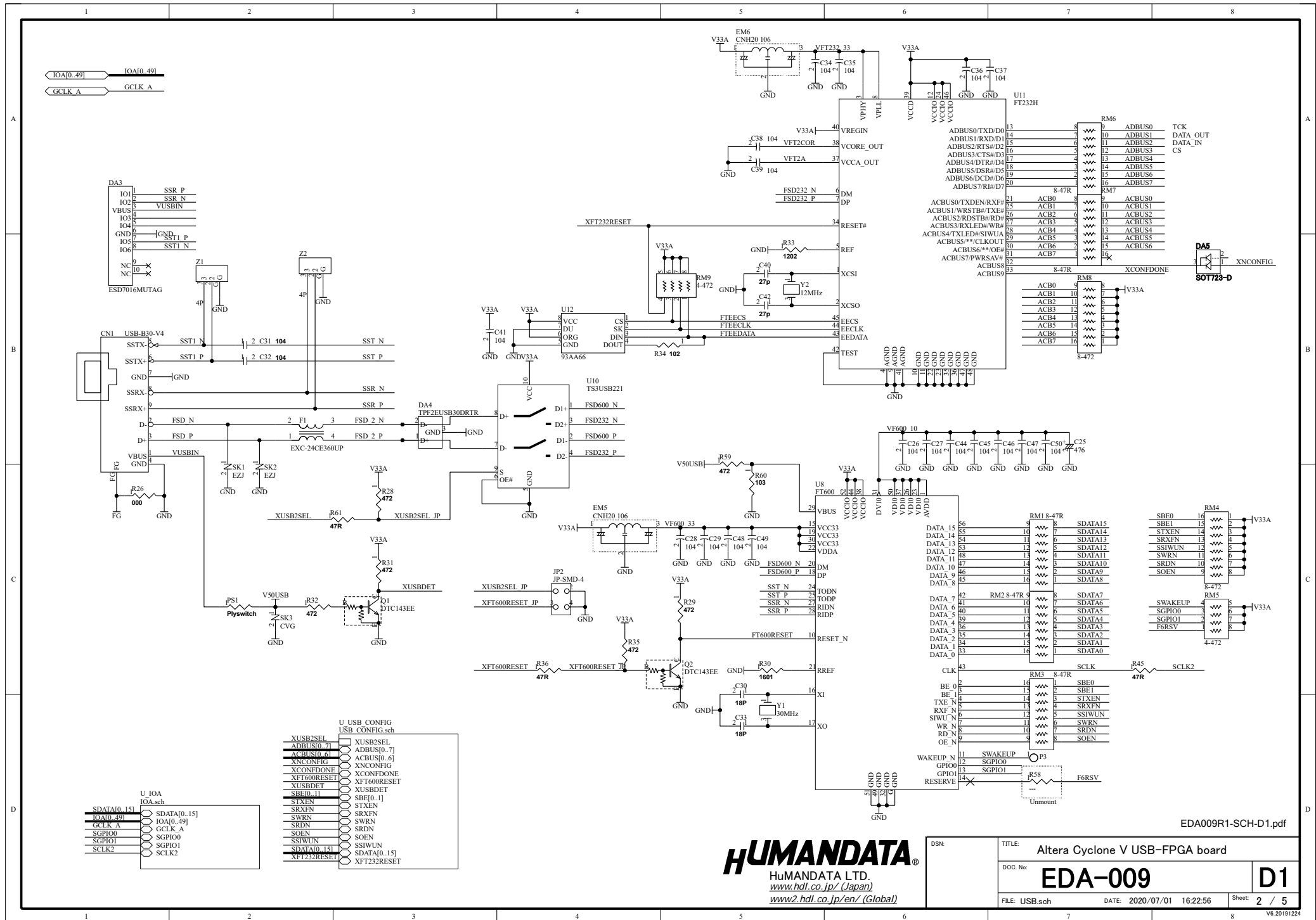

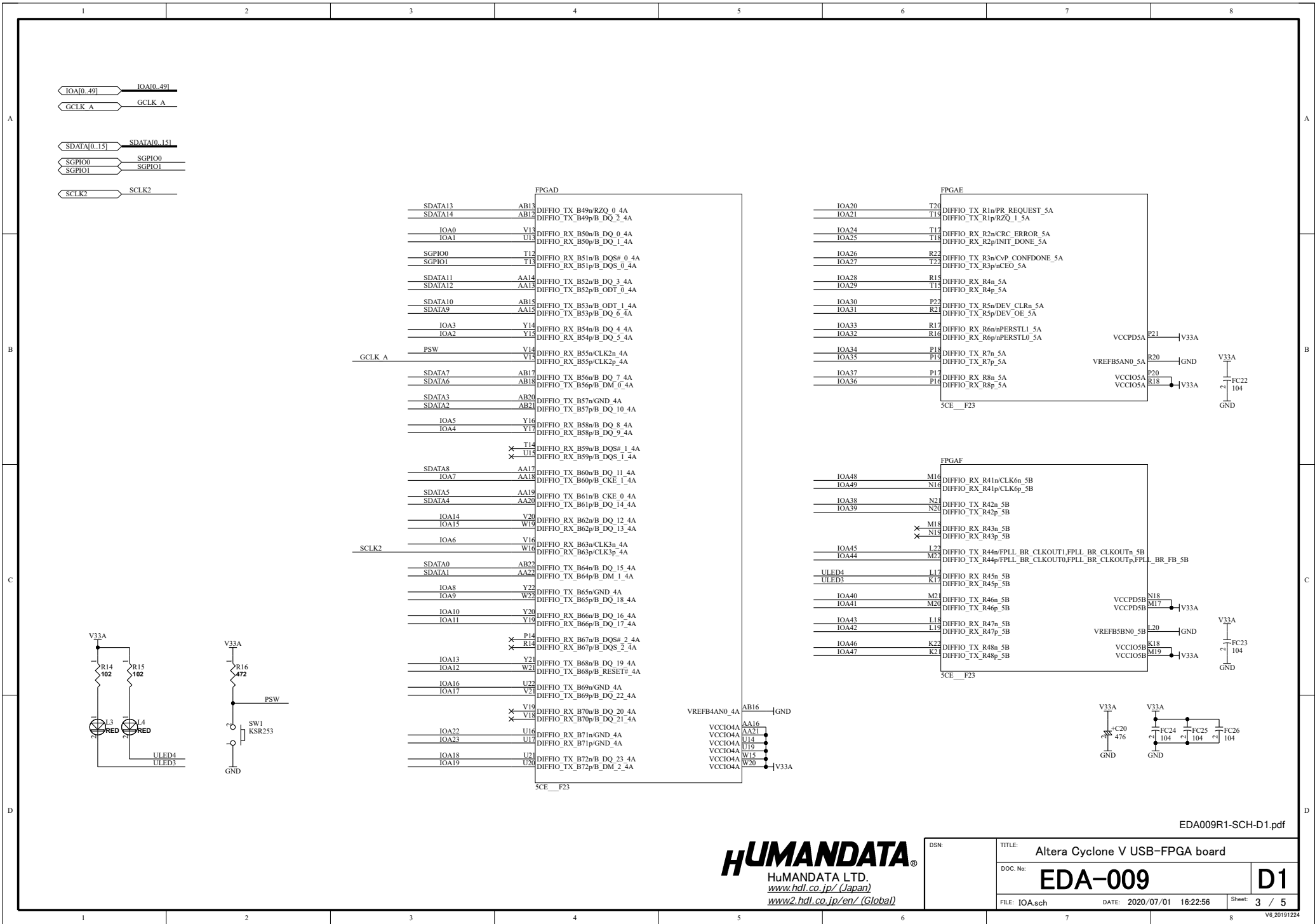

EDA009R1-SCH-D1.pdf

**HUMAN DATA**  
 HUMAN DATA LTD.  
[www.hdl.co.jp/](http://www.hdl.co.jp/) (Japan)  
[www2.hdl.co.jp/en/](http://www2.hdl.co.jp/en/) (Global)

DSN:	TITLE: Altera Cyclone V USB-FPGA board	<b>D1</b>
DOC. No:	<b>EDA-009</b>	
FILE: IOA.sch	DATE: 2020/07/01 16:22:56	Sheet: 3 / 5

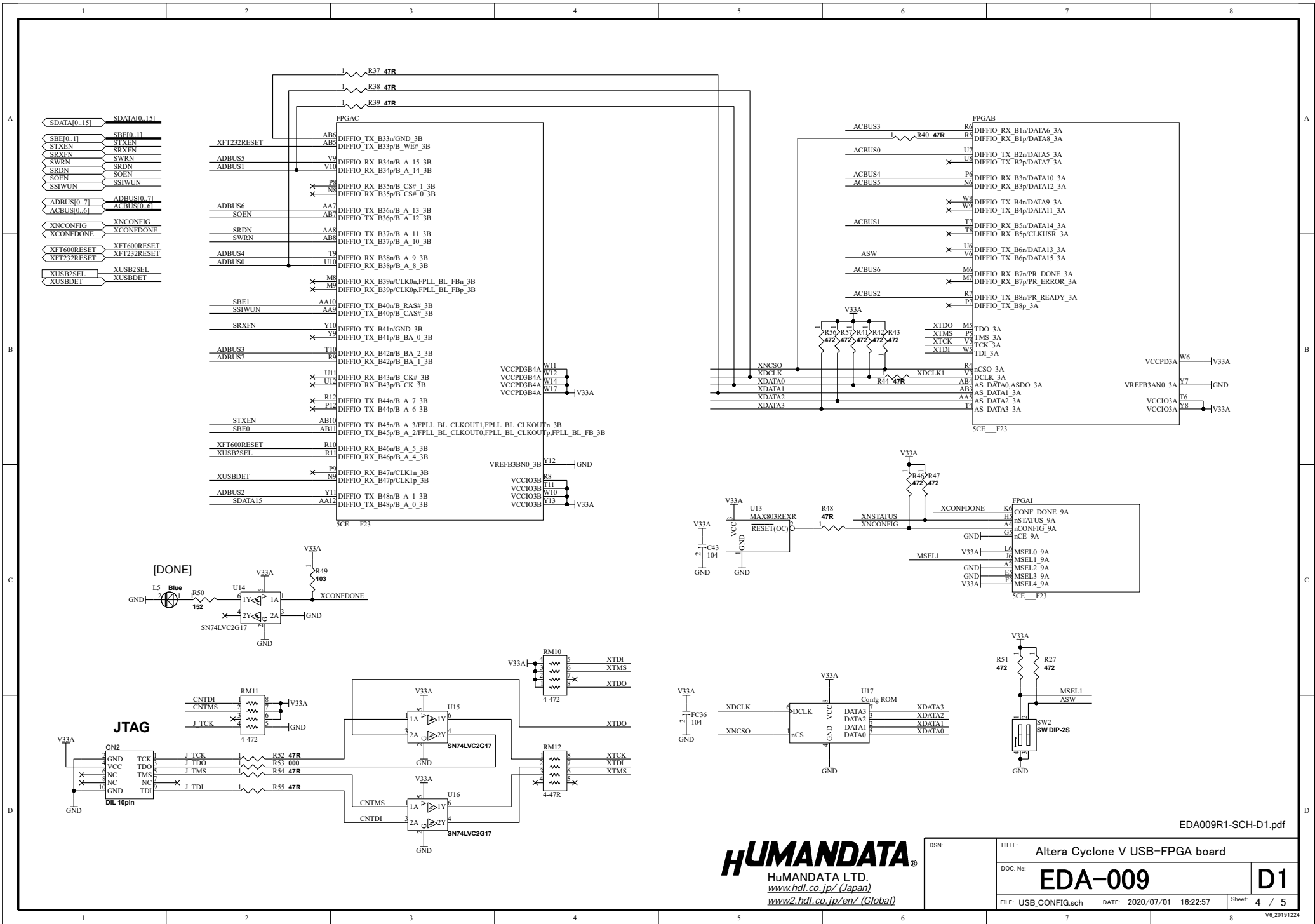

EDA009R1-SCH-D1.pdf

**HUMAN DATA**  
 HuMANDATA LTD.  
[www.hdl.co.jp/ \(Japan\)](http://www.hdl.co.jp/)  
[www2.hdl.co.jp/en/ \(Global\)](http://www2.hdl.co.jp/en/ (Global))

DSN:	TITLE: Altera Cyclone V USB-FPGA board	<b>D1</b>
DOC. No:	<b>EDA-009</b>	
FILE: USB_CONFIG.sch	DATE: 2020/07/01 16:22:57	Sheet: 4 / 5

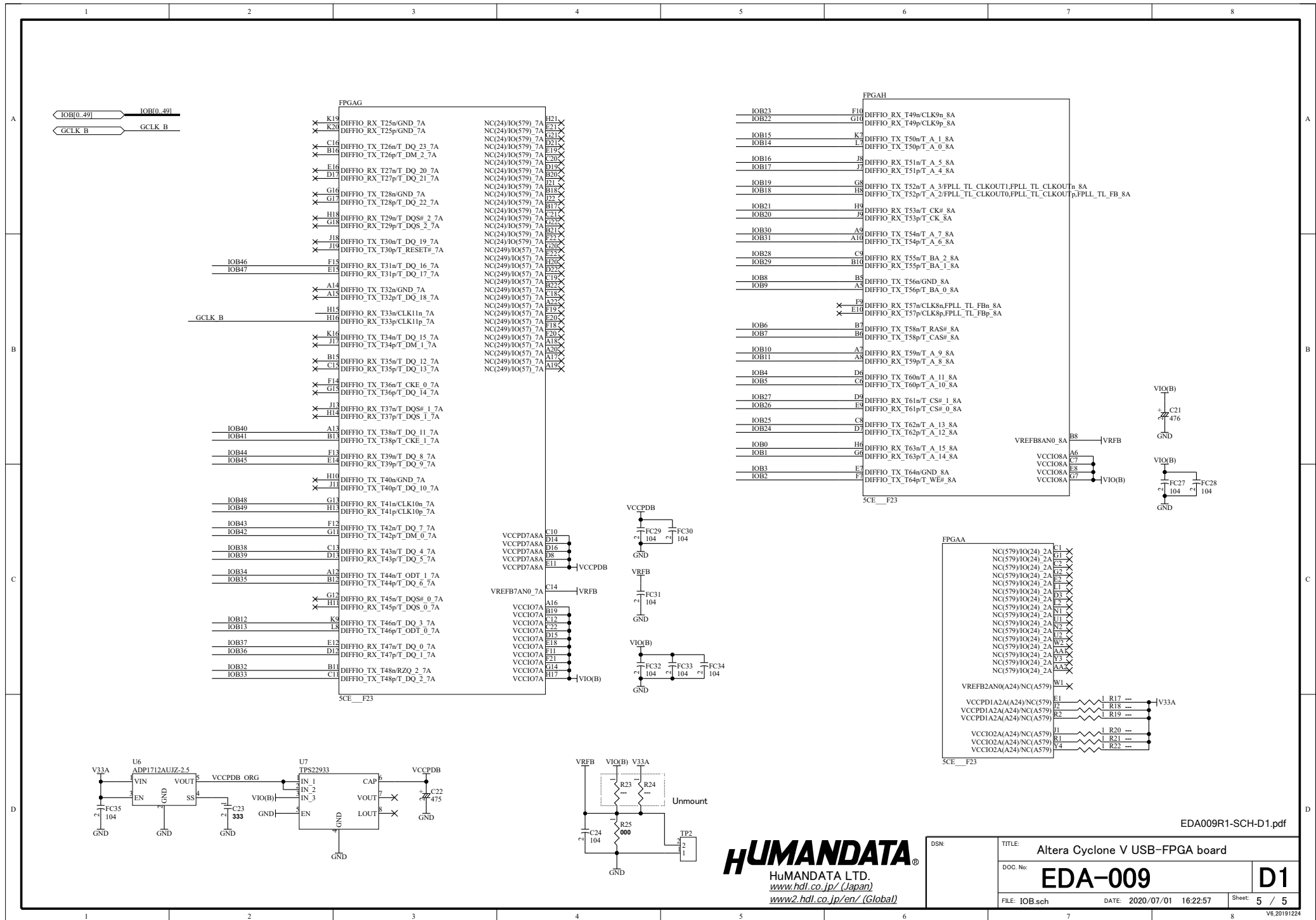

EDA009R1-SCH-D1.pdf

**HUMAN DATA**  
 HUMAN DATA LTD.  
[www.hdl.co.jp/](http://www.hdl.co.jp/) (Japan)  
[www2.hdl.co.jp/en/](http://www2.hdl.co.jp/en/) (Global)

DSN:	TITLE: Altera Cyclone V USB-FPGA board	D1
DOC. No:	EDA-009	
FILE: IOB.sch	DATE: 2020/07/01 16:22:57	Sheet 5 / 5