

TE (AMP) 製 PLCC取り外し工具 AMP8221541

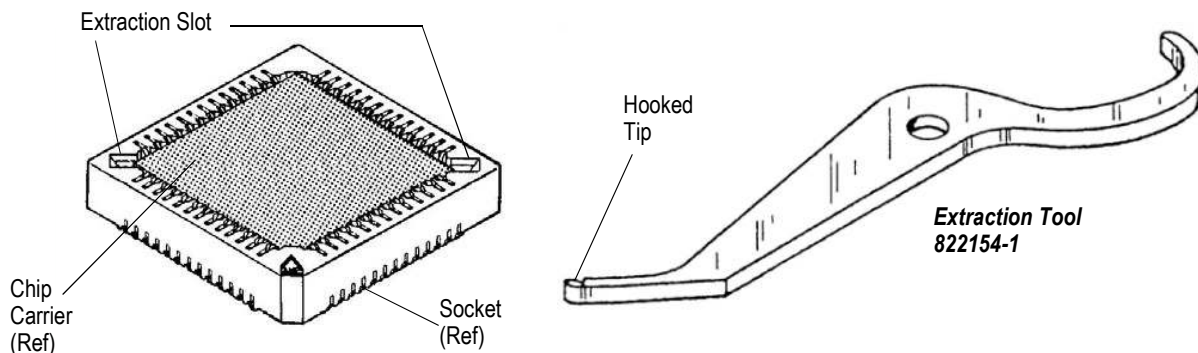

Plastic Leaded Chip Carrier (PLCC)
Extraction Tool 822154-1

Instruction Sheet
408-9695
18 OCT 13 Rev D



SOCKET TYPE AND NO. OF POSITIONS	SOLDERTAIL SOCKET PART NUMBER WITHOUT POST	LOW INSERTION FORCE SOCKET PART NUMBER		
		WITH POST	WITHOUT POST	TAPE
PLCC 20	---	822270-1	822269-1	3-822269-1
PLCC 28	822437-1	822272-1	822271-1	3-822271-1
PLCC 32	822437-2	822274-1	822273-1	3-822273-1
PLCC 44	822437-3	822276-1	822275-1	3-822275-1
PLCC 52	822437-4	822278-1	822277-1	3-822277-1
PLCC 68	822437-5	822280-1	822279-1	3-822279-1
PLCC 84	822437-6	822282-1	822281-1	3-822281-1
SOJ 28•	---	---	822372-1	3-822372-1
SOJ 28••	---	822363-1	822361-1	3-822361-1
SOJ 32•	---	---	822374-1	3-822374-1
SOJ 32••	---	822364-1	822362-1	3-822362-1
SOJ 40••	---	822267-2	822265-2	3-822265-2
SOJ 42••	---	---	822378-1	3-822378-1
SOJ 44••	---	---	822393-1	3-822393-1
SOJ 50•••	---	---	822405-1	3-822405-1

•7.62 mm [.300 in.] centerlines
 ••10.16 mm [.400 in.] centerlines
 •••10.16 mm [.400 in.] centerlines, 0.8 mm pitch

Figure 1

1. INTRODUCTION

This instruction sheet covers the use of Extraction Tool 822154-1. This tool is designed to remove chip carriers from the TE Connectivity surface mount low insertion force sockets, SOJ (Small Outline J-Leaded) sockets, and solder tail sockets listed in Figure 1.



NOTE

Dimensions are in millimeters [with inch equivalents in brackets]. Figures and illustrations are for reference only and are not drawn to scale.

Reasons for reissue of this sheet are provided in Section 5, REVISION SUMMARY.

2. DESCRIPTION

This tool is contoured for insertion into either of the two extraction cavities on the socket. By inserting the extraction tool with the correct angle (see Figure 2), and pivoting the tool on its heel against the socket, the chip carrier is easily removed.

3. EXTRACTION PROCEDURE

1. Orient the socket and tool as shown in Figure 3.
2. Insert the extraction tool into the socket so that the front angle of the tool is perpendicular to the chip carrier.



CAUTION

Insertion of the extraction tool with an incorrect angle will result in damage to the socket. This incorrect angle will bottom under the stand-off rather than the bottom of the chip carrier.

3. Lower extraction tool into extraction cavity until it bottoms.
4. With a slight downward pressure, rotate the tool away from the chip carrier until the corner of the chip carrier lifts away from the socket.
5. Repeat on opposite extraction slot and lift chip carrier out of socket.

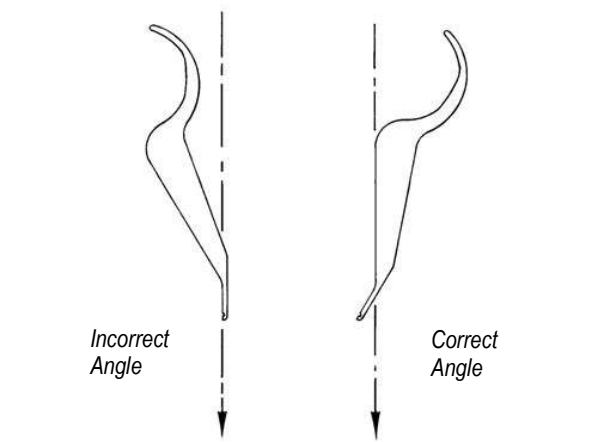
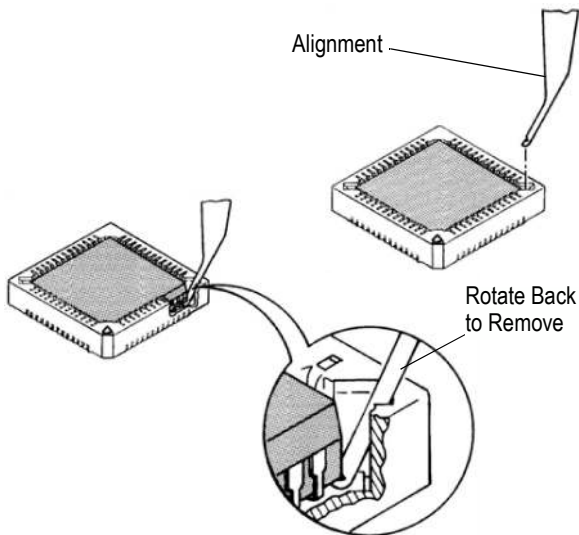

Figure 2



CAUTION

Do not attempt to completely extract chip carrier from socket on the first extraction. Lift from one side until the corner is above the socket, then repeat procedure on opposite corner.

Figure 3

4. TOOL INSPECTION

Extraction Tool 822154-1 has been inspected and should be verified with the information provided in Figure 4. It is recommended that the tool be inspected immediately upon its arrival at your facility (and at regularly scheduled intervals) to ensure that the tool has not been damaged during handling.

For additional information concerning extraction tools for PLCC and SOJ sockets, or to purchase additional tools, contact your local TE Representative or:

CUSTOMER SERVICE (038-035)
 TYCO ELECTRONICS CORPORATION
 PO BOX 3608
 HARRISBURG PA 17105-3608

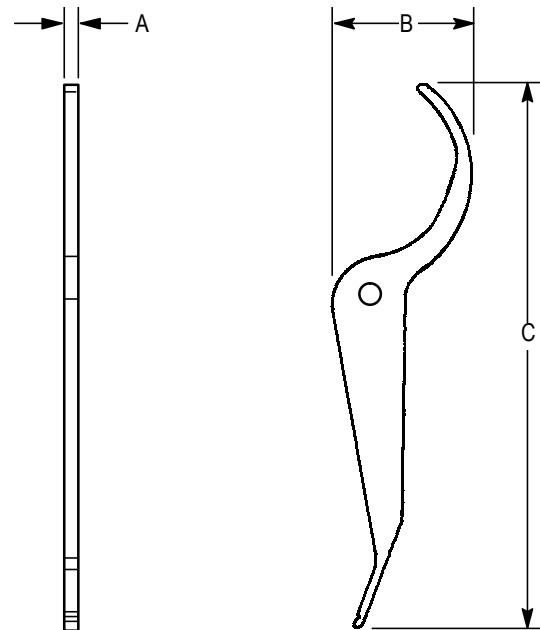

TOOL SPECIFICATIONS

PART NUMBER	DIMENSIONS		WEIGHT	MATERIAL
822154-1	A	1.27 ±0.05 [.050 ±.002]	3.1 g [.11 oz]	Spring Steel Alloy
	B	18.54 ±0.13 [.730 ±.005]		
	C	63.50 ±0.13 [2.500 ±.005]		

Figure 4

5. REVISION SUMMARY

Revisions to this document include:

- Updated document to corporate requirements
- New logo

Rev D

一回の作業で完全に取り外そうとはしないでください。
 ICの角がソケットより上がった時点で反対側も持ち上げるようにしてください。