

USB to 4-20mA Generator 
USB-034 (Rev2)
User's Manual
Ver. 1.0

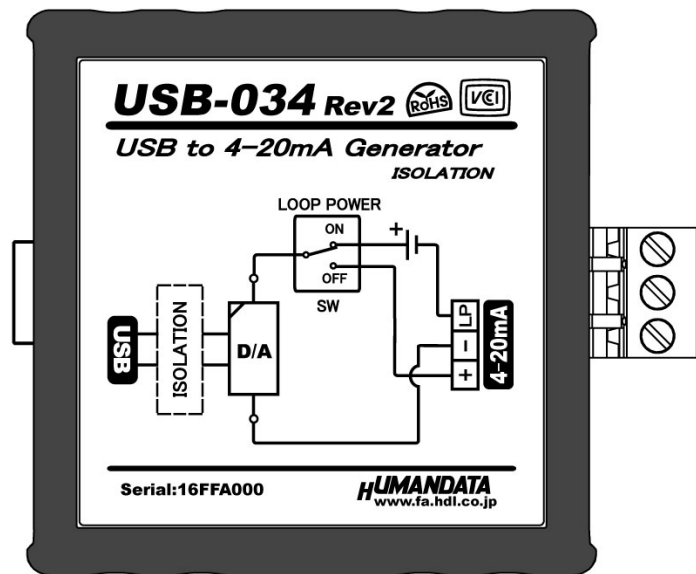



HuMANDATA LTD.

Table of Contents

I	Precautions.....	1
I	Revision History.....	1
I	Introduction.....	2
1.	Overview.....	2
1.1.	Main Power	3
1.2.	Nameplate.....	3
1.3.	Loop Power Enable Switch.....	3
1.4.	Current Output Connector.....	4
1.5.	Connection Examples	4
2.	Specifications.....	5
2.1.	Product Specification	5
2.2.	Optional Accessories.....	6
3.	CDC Class Driver Installation Guide.....	6
4.	Control Command.....	7
4.1.	Overview of Control Commands	7
4.2.	Control Sequence.....	7
4.3.	Control Command List	8
4.4.	Error Codes	14
4.5.	Example of Command Verification Using Communication Software	15
5.	Dedicated Application (USB to 4-20 mA Generator)	16
6.	Additional Documentation and User Support.....	17
7.	Warranty and Compensation.....	17

I Precautions

 Do Not	1	This product uses ordinary off-the-shelf electronic components, and is therefore inappropriate for use in applications that require special quality or reliability and are expected to protect human lives or prevent accidents, such as safety mechanisms in fields including space, aeronautics, medicine, and nuclear power.
	2	Do not be used underwater or in high-humidity environments.
	3	Do not be used in the presence of corrosive gases, combustible gases, or other flammable gases.
	4	Do not turn on power when circuit board surface is in contact with other metal.
	5	Do not apply voltage higher than rated voltage.

 Attention	6	This manual may be revised in the future without notice owing to improvements.
	7	All efforts have been made to produce the best manual possible, but if users notice an error or other problem, we ask that they notify us.
	8	Item 7 notwithstanding, HuMANDATA cannot be held liable for the consequences arising from use of this product.
	9	HuMANDATA cannot be held liable for consequences arising from using this product in a way different from the uses described herein, or from uses not shown herein.
	10	This manual, circuit diagrams, sample circuits, and other content may not be copied, reproduced, or distributed without permission.
	11	If the product emits smoke, catches fire, or becomes unusually hot, cut the power immediately.
	12	Do not install the control cables or communication cables together with the main circuit lines or power cables. In such an environment, it may result in malfunction due to noise.
	13	Be careful of static electricity.

I Revision History

Date	Revision	Description
Apr. 22, 2026	v1.0	Initial release

I Introduction

USB-034 is a generator that allows control of 4-20mA signals from a computer via USB. The USB side and the 4-20 mA output side are electrically isolated. It also includes a built-in loop power supply for the 4-20 mA side.

USB-034 can be used as a 4-20mA signal generator when utilizing a computer for instrumentation and control applications.

Dedicated control commands are also provided, allowing the 4-20 mA output to be controlled from your own custom applications.

1. Overview

USB Host side

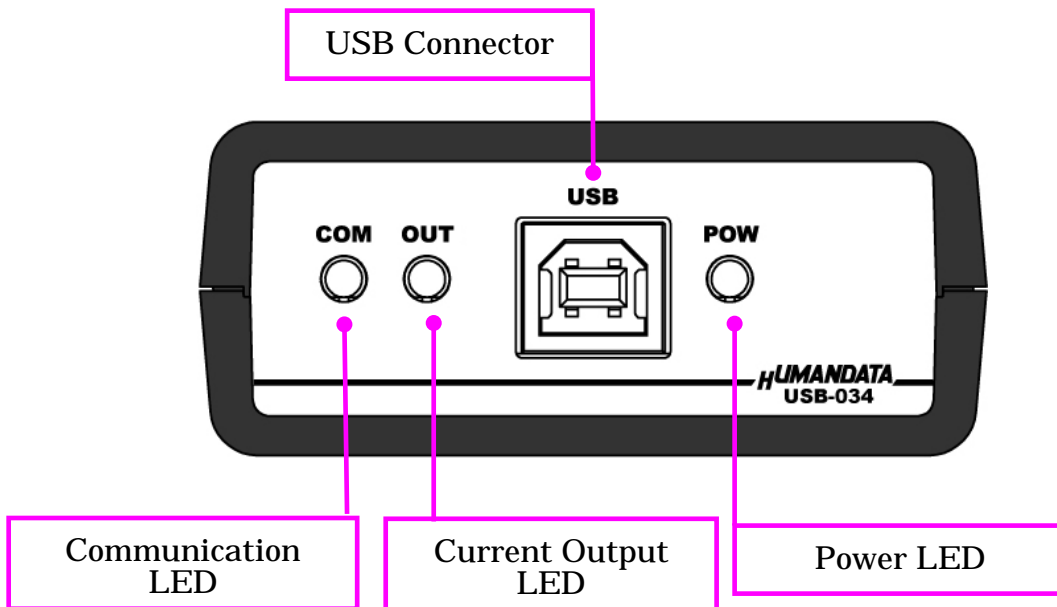

4-20mA Output side

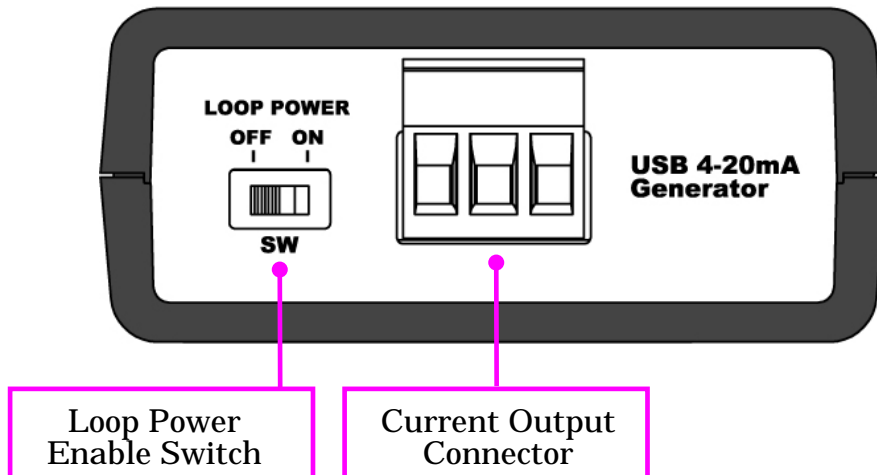

1.1. Main Power

USB-034 is powered through a computer's USB port (Bus-powered).

1.2. Nameplate

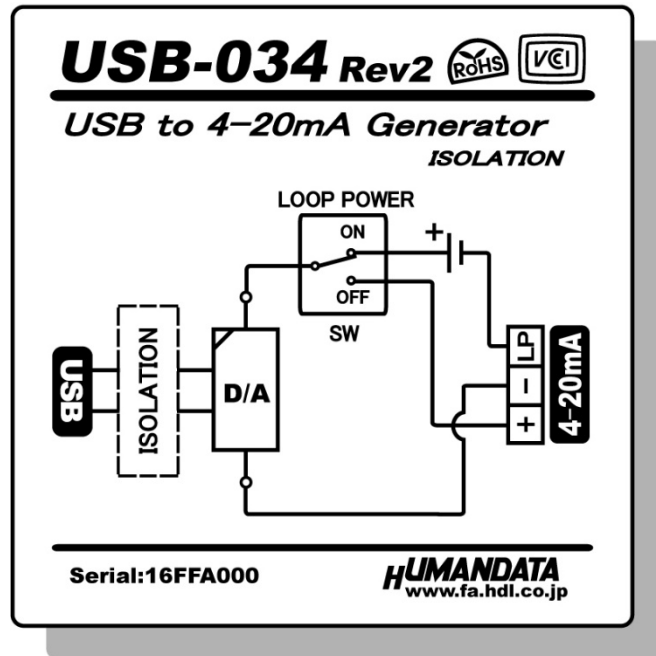

The USB side and the 4-20 mA output side are electrically isolated.

1.3. Loop Power Enable Switch

Used to configure loop power supply:

OFF: External loop power supply

ON: Internal loop power supply (built-in USB-034)

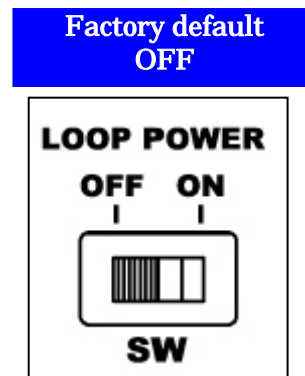

1.4. Current Output Connector

Do not connect/disconnect while powered.

Pin Assignment	Signal
1	Current Terminal (+)
2	Current Terminal (-)
3	Loop Power (LP)

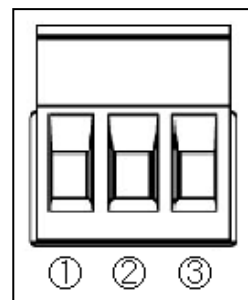

Note: Follow this document over connector manufacturer markings.

Connector: Phoenix Contact 1757022
Supported wire: AWG24 (0.2 sq) to AWG12 (3.5 sq)

1.5. Connection Examples

[When supplying loop power from an external source]

- Set the loop power switch to the OFF position
- Connect to current output connector terminals 1 and 2



[When supplying from the built-in loop power]

- Set the loop power switch to the ON position
- Connect to current output connector terminals 2 and 3



2. Specifications



2.1. Product Specification

Item	Description	Remarks
Model	USB-034	
Input Power	DC5V / 400mA max. Supplied via USB cable	
HOST interface	USB 2.0 compliant (Full-Speed supported) USB-B connector	· USB 1.1 compatible · ESD protection $\pm 11\text{KV}$
Output Connector	3-pin terminal block	Phoenix Contact Model: 1759020
Output Range	4-20mA or 3.2-24mA	Selectable by command
Resolution	16-bit D/A Converter (DAC)	
Output Accuracy	0.05% FS or less (@25°C)	When output range is 4-20 mA
Alarm Current	Downscale alarm current: 3.2 mA Upscale alarm current: 22.8 / 24 mA	Selectable by command
External Loop Power Supply	DC20-52 V	Drive capability varies depending on the supplied voltage.
Load Resistance	When using built-in loop power supply: 1200 Ω max. When using external loop power supply: 1200 Ω max. (@DC52 V) 500 Ω max. (@DC24 V)	
Isolation Method	Bus Isolation	
Isolation Protection	DC1500V	Designed value
LSI	General-purpose microcontroller 4-20mA DAC	
LED	Status LED x 2 Power LED	
Control Method	Communication control via virtual COM port	
Operating Ambient Temp.	-20 to 60[°C] (-4 to 140 [°F])	No condensation permitted
Operating Ambient Humi.	30 to 85%RH	
Storage Ambient Temp.	-20 to 60[°C] (-4 to 140 [°F])	
Storage Ambient Humi.	30 to 85%RH	
Noise Immunity	Not specified	
Compliance Standards	VCCI Class B	
Weight	Approx. 90 [g]	Only main body
Dimensions	67 x 67 x 28 [mm] (2.638" x 2.638" x 1.102")	Without projections

* There is a case to be changed to the parts of the compatibility.

* Power saving function (suspend, standby, sleep and others) is not supported.

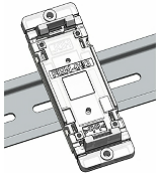
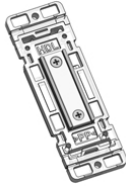
2.2. Optional Accessories

MODEL	Image	品名
PEN-003		Attachment with clamping screw JAN : 4937920800709
PEN-003-DIN		Attachment for 35mm DIN rail JAN : 4937920800716
PEN-003-MG		Attachment with neodymium magnet JAN : 4937920801201
TB-USB-3		Detachable 3P Terminal Connector 1757022 (Phoenix) JAN : 4937920801263

3. CDC Class Driver Installation Guide

USB-034 uses the CDC (Communication Device Class) driver, which is included in the operating system.

Windows 10 or later:

No driver installation required. Automatically recognized as a "USB Serial Device (COM*)".

* Driver installation is required in the following cases:

- When using Windows 8.1 or earlier
- When using Windows 10 or later, so that the device is recognized by its model name in Device Manager

The device driver and installation manual can be downloaded from the product documentation page. Please refer to Chapter 6, "Additional Documentation and User Support."

4. Control Command

4.1. Overview of Control Commands

By using control commands, you can control the 4-20 mA output from your own application. A control command consists of a command character, sequence number, parameter(s), and an end code, separated by commas. Some commands do not require parameters.

The sequence number {SQNO} is an arbitrary string (up to 5 characters).

USB-034 returns the same sequence number in its response, allowing the host to match commands with responses.

ASCII characters are assigned to the control commands, allowing operation to be verified by keyboard input using a terminal application such as Tera Term.

Use uppercase letters for command characters.

Example

	Command {CMD}	Comma {,}	Sequence number {SQNO}	Comma {,}	Parameter {PRAM}	End code <CR>
HEX	41h	2Ch	31h 32h 33h	2Ch	34h 30h 39h 36h	0Dh
ASCII	A	,	123	,	4096	CR

4.2. Control Sequence

1. The PC sends a command to the USB-034.
2. USB-034 detects the end code <CR> and returns a response. The PC checks this response to confirm that the command was received correctly. Refer to the command list for response formats.

When sending multiple commands, always wait for the response to the previous command before sending the next one.

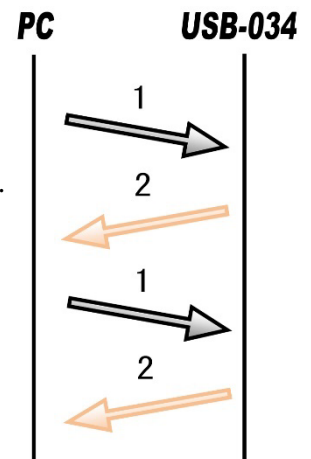

- * When the K command (wire-break detection) is enabled, the USB-034 sends “ER001” automatically if a wire-break is detected.
- * When the P command (loop-power recovery notification) is enabled, the USB-034 sends “CM001” if loop power is recovered.
- * While J (auto-step) or Y (auto-sweep) is running, the USB-034 periodically sends the current output value.

If the USB-034 does not respond

The USB-034 may not be powered

- Check the USB cable connection
- Check that the POW LED is lit

If using a USB hub

- Ensure other USB devices are not consuming too much power
- Try connecting the USB-034 directly to the PC

4.3. Control Command List

No.	Command	Function	Format
1	N	Loop power ON	N,{SQNO}<CR>
2	H	Loop power OFF	H,{SQNO}<CR>
3	C	Select alarm current	C,{SQNO},{PRAM}<CR>
4	F	Output alarm current	F,{SQNO}<CR>
5	A	Update and output current	A,{SQNO},{PRAM}<CR>
6	S	Update current value	S,{SQNO},{PRAM}<CR>
7	L	Output current	L,{SQNO}<CR>
8	D	Read current value	D,{SQNO}<CR>
9	E	Read loop voltage	E,{SQNO}<CR>
10	T	Read chip temperature	T,{SQNO}<CR>
11	R	Select output range	R,{SQNO},{PRAM}<CR>
12	K	Wire-break detection	K,{SQNO},{PRAM}<CR>
13	P	Loop-power recovery detection	P,{SQNO},{PRAM}<CR>
14	J	Start auto-step	J,{SQNO},{PRAM1}...{PRAM5}<CR>
15	Y	Start auto-sweep	Y,{SQNO},{PRAM1}...{PRAM4}<CR>
16	M	Stop auto-step/sweep	M,{SQNO}<CR>
17	O	Offset setting	O,{SQNO},{PRAM}<CR>
18	W	Watchdog timeout setting	W,{SQNO},{PRAM}<CR>
19	B	Watchdog function	B,{SQNO},{PRAM}<CR>
20	X	Watchdog trigger input	X,{SQNO}<CR>

The commands are explained below.

(The sequence number is fixed at "123", and the output range is set to "4-20 mA".)

1. N Command (Loop power ON)

Format		N,{SQNO}<CR>
Function		Turns ON the internal loop current circuit and enables current output. The default output current is 4 mA, but the current value can be preset using the S command. If the current output was disabled using the H command, sending the N command again restores the current value that was output before the shutdown.
Example	Send	N,123<CR>
	Response	OK,N,123<CR>

2. H Command (Loop power OFF)

Format		H,{SQNO}<CR>
Function		Turns OFF the internal loop current circuit and disables current output.
Example	Send	H,123<CR>
	Response	OK,H,123<CR>

3. C Command (Select alarm current)

Format		C,{SQNO},{PRAM}<CR>
Function		Selects the alarm current value. When the USB-034 power is turned OFF, the parameter returns to the default value (3.2 mA).
Parameter Range		1 (default): 3.2 mA 2 : 22.8 mA (4-20 mA range) or 24 mA (3.2-24 mA range)
Example	Send	C,123,2<CR> * When set to 2 (22.8mA or 24mA)
	Response	OK,C,123<CR>

4. F Command (Output alarm current)

Format		F,{SQNO}<CR>
Function		Forces the output of the alarm current. The alarm current value is selected using the C command (3.2 mA or 22.8 mA).
Example	Send	F,123<CR>
	Response	OK,F,123<CR>

5. A Command (Update and output current)

Format		A,{SQNO},{PRAM}<CR>
Function		Updates the current value and immediately outputs it. This command is equivalent to : S command → L command When the USB-034 power is turned OFF, the parameter returns to the default value (0).
Parameter Range		0 – 65535 (default: 0) Relationship between parameter and current value 0: <u>4mA</u> 1: <u>4.00024mA</u> ... 32767: <u>11.9997mA</u> 32768: <u>12mA</u> ... 65535: <u>19.9997mA</u>
Example	Send	A,123,4096<CR> * When set to 4096 (5 mA)
	Response	OK,A,123<CR>

6. S Command (Update current value)

Format		S,{SQNO},{PRAM}<CR>
Function		Updates the current value but does not change the output current. The new value becomes effective when the L command is sent. When the USB-034 power is turned OFF, the parameter returns to the default value (0).
Parameter Range		0 – 65535 (default: 0) Relationship between parameter and current value 0: <u> 4mA</u> 1: <u> 4.00024mA</u> ... 32767: <u> 11.9997mA</u> 32768: <u> 12mA</u> ... 65535: <u> 19.9997mA</u>
Example	Send	S,123,4096<CR> * When set to 4096 (5 mA)
	Response	OK,S,123<CR>

7. L Command (Output current)

Format		L,{SQNO}<CR>
Function		Outputs the current value set by the S command.
Example	Send	L,123<CR>
	Response	OK,L,123<CR>

8. D Command (Read current value)

Format		D,{SQNO}<CR>
Function		Reads the current parameter value.
Example	Send	D,123<CR>
	Response	OK,D,123,4096<CR> * When set to 4096 (5 mA)

9. E Command (Read loop voltage)

Format		E,{SQNO}<CR>
Function		Reads the 8-bit digital code (D) of the loop voltage. The loop voltage can be calculated from this value using the following formula. Loop Voltage [V] = (2.5 / 256) × D
Example	Send	E,123<CR>
	Response	OK,E,123,186<CR> * When D = 186

10. T Command (Read chip temperature)

Format		T,{SQNO}<CR>
Function		Reads the 8-bit digital code (D) of the chip temperature. The temperature can be calculated from this value using the following formula. Chip Temperature [°C] = 125 – (1.771 × (D – 128))
Example	Send	T,123<CR>
	Response	OK,T,123,184<CR> * When D = 184

11. R Command (Select output range)

Format		R,{SQNO},{PRAM}<CR>
Function		Selects the output current range (4-20 mA or 3.2-24 mA). When the USB-034 power is turned ON, the default range is 4-20 mA. If the 3.2-24 mA range is used, the range must be selected before sending the N command.
Parameter Range		1 (default): 4-20 mA 2 : 3.2-24 mA
Example	Send	R,123,2<CR> * When using the 3.2-24 mA range
	Response	OK,R,123<CR>

12. K Command (Wire-break detection)

Format		K,{SQNO},{PRAM}<CR>
Function		Enables or disables the wire-break detection function during current output. When this function is enabled and the wire-break is detected, the USB-034 sends ER001. When the USB-034 power is turned ON, the default setting is disabled. This function must be enabled before sending the N command.
Parameter Range		1 (default): Disabled 2 : Enabled
Example	Send	K,123,2<CR> * When the wire-break detection is enabled
	Response	OK,K,123<CR>
	Response when wire-break is detected	ER001<CR>

13. P Command (Loop-power recovery detection)

Format		P,{SQNO},{PRAM}<CR>
Function		Enables or disables the loop-power recovery detection function. When this function is enabled and the loop-power recovery is detected, the USB-034 sends CM001. When the USB-034 power is turned ON, the default setting is disabled. This function must be enabled before sending the N command.
Parameter Range		1 (default): Disabled 2 : Enabled
Example	Send	P,123,2<CR> * When the loop-power recovery detection is enabled
	Response	OK,P,123<CR>
	Response when loop-power recovery is detected	CM001<CR>

14. J Command (Start auto-step)

Format		J,{SQNO},{PRAM},{PRAM2},{PRAM3},{PRAM4},{PRAM5}<CR>
Function		Starts the auto-step operation. Step size, start value, and end value are set using 16-bit parameters.
Parameter Range		PRAM: Step size (Range : 0 – 65535) PRAM2: Start value (Range : 0 – 65535) PRAM3: End value (Range : 0 – 65535) PRAM4: Hold time [×10ms] (Range : 0 – 60000) PRAM5: Mode selection (Range : 1 – 8) 1: Increase 2: Decrease 3: Increase → Decrease 4: Increase (repeat) 5: Decrease (repeat) 6: Increase → Decrease (repeat) 7: Decrease → Increase 8: Decrease → Increase (repeat)
Example	Send	J,123,4096,0,65535,10,6<CR> * Step size: 1mA, Start value: 4mA, End value: 20mA Hold time: 100ms, Mode: Set to 6
	Response	OK,J,123<CR> OK,J,123,0<CR> OK,J,123,4096<CR> OK,J,123,8192<CR> OK,J,123,12288<CR> ...

15. Y Command (Start auto-sweep)

Format		Y,{SQNO},{PRAM},{PRAM2},{PRAM3},{PRAM4}<CR>
Function		Starts the auto-sweep operation. Step size, start value, and end value are set using 16-bit parameters.
Parameter Range		PRAM: Sweep count (Range : 0 – 999999999) PRAM2: Start value (Range : 0 – 65535) PRAM3: End value (Range : 0 – 65535) PRAM4: Hold time [×10ms] (Range : 0 – 60000)
Example	Send	Y,123,100,0,65535,10<CR> * Sweep count: 100, Start value: 4mA, End value: 20mA Hold time: 100ms
	Response	OK,Y,123<CR> OK,Y,123,0<CR> OK,Y,123,65535<CR> OK,Y,123,0<CR> OK,Y,123,65535<CR> ...

16. M Command (Stop auto-step/sweep)

Format		M,{SQNO}<CR>
Function		Stops the auto-step or auto-sweep operation.
Example	Send	M,123<CR>
	Response	OK,M,123<CR>

17. O Command (Offset setting)

Format	O,{SQNO},{PRAM}<CR>	
Function	Sets the output current offset. An offset within ± 8 mA can be applied.	
Parameter Range	Range : 0 - 65535 0 : -8 mA 32768(default) : 0 mA (no offset) 65535 : +8 mA	
Example	Send	O,123,36864<CR> * When setting the offset of 4096 (+1mA)
	Response	OK,O,123<CR>

18. W Command (Watchdog timeout setting)

Format	W,{SQNO},{PRAM}<CR>	
Function	Sets the watchdog timeout value. If the watchdog trigger (X command) is not received within this time, the current output will be turned OFF.	
Parameter Range	1 - 60000 [$\times 10$ ms] (default: 1000)	
Example	Send	W,123,1500<CR> * When set to 15 seconds
	Response	OK,W,123,1500<CR>

19. B Command (Watchdog function)

Format	B,{SQNO},{PRAM}<CR>	
Function	When the watchdog function is enabled, the output current value to be applied when the PC or application freezes can be configured. Once enabled, the USB-034 starts monitoring the watchdog input trigger. If a watchdog input trigger is received before the timer value is reached, the timer is reset. If the timer value is reached (i.e., when a freeze occurs), the loop power is turned off or an alarm current is output. If an auto-step or auto-sweep operation is in progress, the operation is stopped.	
Parameter Range	Range: 1 - 3 1 (default): Disabled 2: Enabled (loop power OFF at timeout) 3: Enabled (alarm current output at timeout)	
Example	Send	B,123,2<CR> * When enabling the watchdog function
	Response	OK,B,123,2<CR>

20. X Command (Watchdog trigger input)

Format	X,{SQNO}<CR>	
Function	Watchdog trigger command. Resets the watchdog timer. The response includes the current watchdog timer value ($\times 10$ ms).	
Example	Send	X,123<CR>
	Response	OK,X,123,500<CR> * When the watchdog timer value is 5 seconds

4.4. Error Codes

If a control command cannot be processed successfully, an error code is returned.

ER001	Loop Power OFF	The loop power is OFF. Check: <ul style="list-style-type: none"> · Whether the N command has enabled current output · Whether the loop wiring is correctly connected outside the output connector
	Response	ER001<CR>
ER002	Command Error	The command is invalid. This error also occurs if: <ul style="list-style-type: none"> · The SQNO length exceeds the limit · SQNO data is missing Maximum SQNO length : 5 characters
	Response	ER002<CR>
ER003	Parameter Setting Error	The parameter is outside the allowed range or the parameter data is missing.
	Response	ER003<CR>
ER031	Loop Voltage Low	The loop voltage is too low. Check: <ul style="list-style-type: none"> · Whether the connected load is too large · Whether the external loop power supply voltage is within the specified range The loop voltage can be read using the E command. This error occurs when : Loop voltage ≤ 0.3 V The error clears when : Loop voltage ≥ 0.4 V The 8-bit digital code (D) of the loop voltage is also returned.
	Response	ER031, 21<CR> * When D = 21 (0.21V)
ER032	Chip Temperature Error	The internal chip temperature of the USB-034 exceeds 140°C. Check that the device is used within the specified operating temperature range. The chip temperature can be read using the T command. Error condition : Temperature $\geq 140^\circ\text{C}$ The error clears when : Temperature $\leq 125^\circ\text{C}$ The 8-bit digital code (D) is also returned.
	Response	ER032, 117<CR> * When D = 117 (145°C)
ER033	Loop Current Error	The actual current differs from the value specified by the A command.
	Response	ER033<CR>
ER034	Watchdog Trigger Invalid	The watchdog trigger (X command) was received in one of the following states: <ul style="list-style-type: none"> · Loop power OFF · Alarm current output active · Watchdog function disabled
	Response	ER034<CR>

4.5. Example of Command Verification Using Communication Software

The communication software Tera Term is a terminal application for Microsoft Windows that sends characters entered from the keyboard to the connected device and displays the characters returned from the device.

1. Connect the Device

Connect the USB-034 to the PC. Start Tera Term and select “New connection”. Select the serial port and click OK.

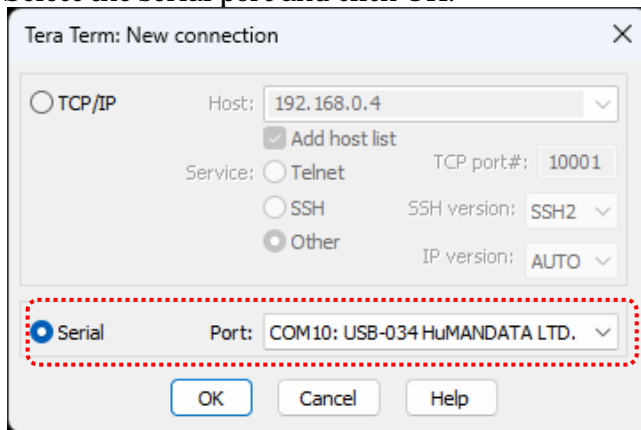

2. Enable Local Echo

Open Terminal Setup > Terminal... and check Local echo so that the characters entered from the keyboard are displayed on the screen. Click OK.

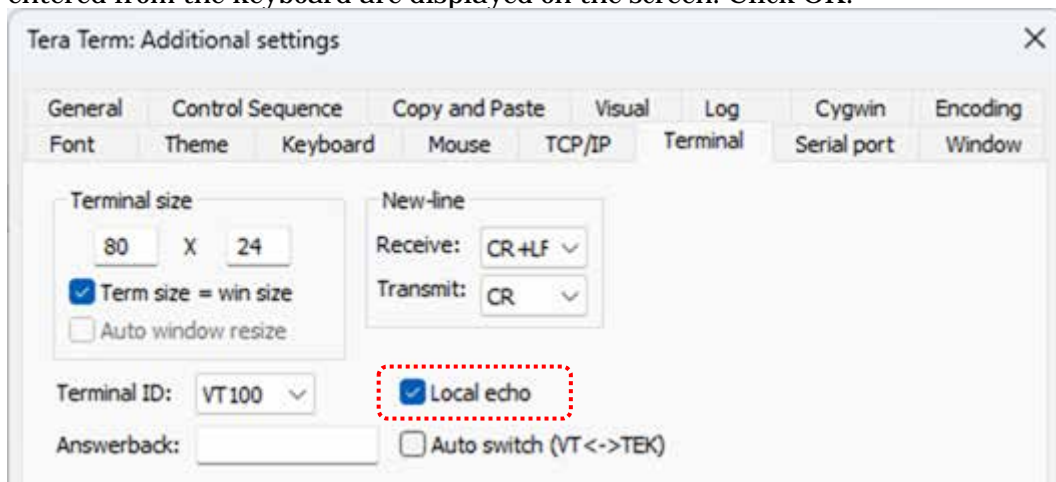

3. Enter Commands

Enter commands in the terminal and confirm the operation of the USB-034.

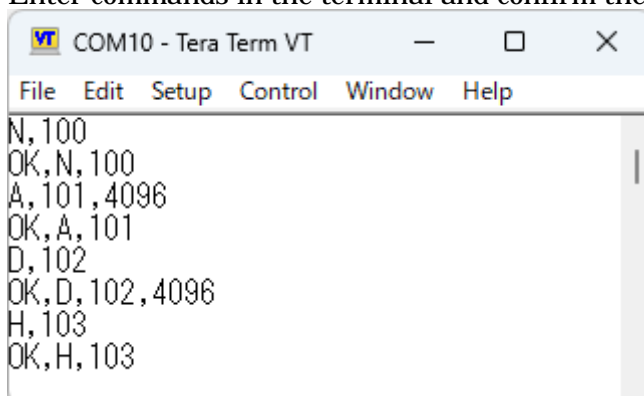

5. Dedicated Application (USB to 4-20 mA Generator)

The dedicated application USB to 4-20mA Generator is available for USB-034. This application sends control commands to the USB-034 and outputs a 4-20 mA current signal. It provides functions such as current output with scaling settings, Auto Step, and Auto Sweep operations.

This application software and the user's manual can be downloaded from the documentation page. Please refer to Chapter 6, "Additional Documentation and User Support."

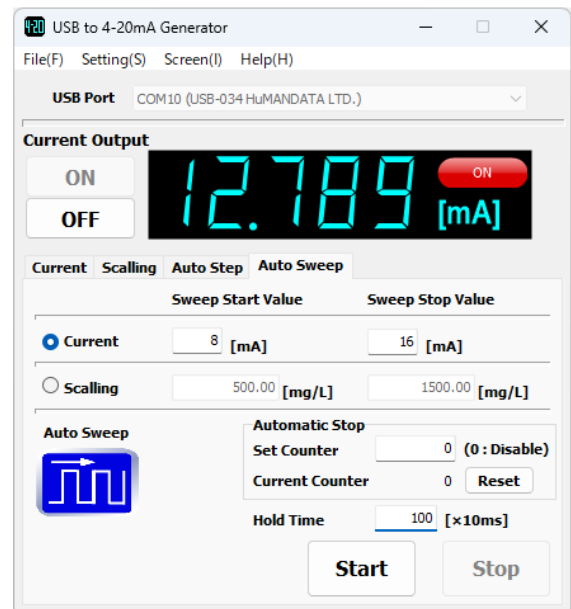
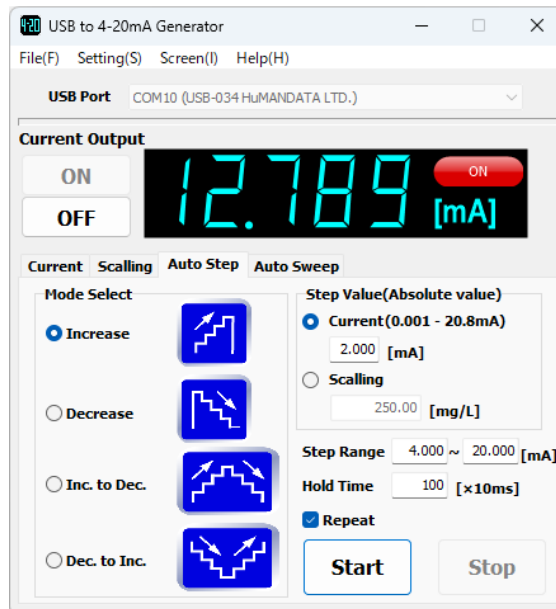
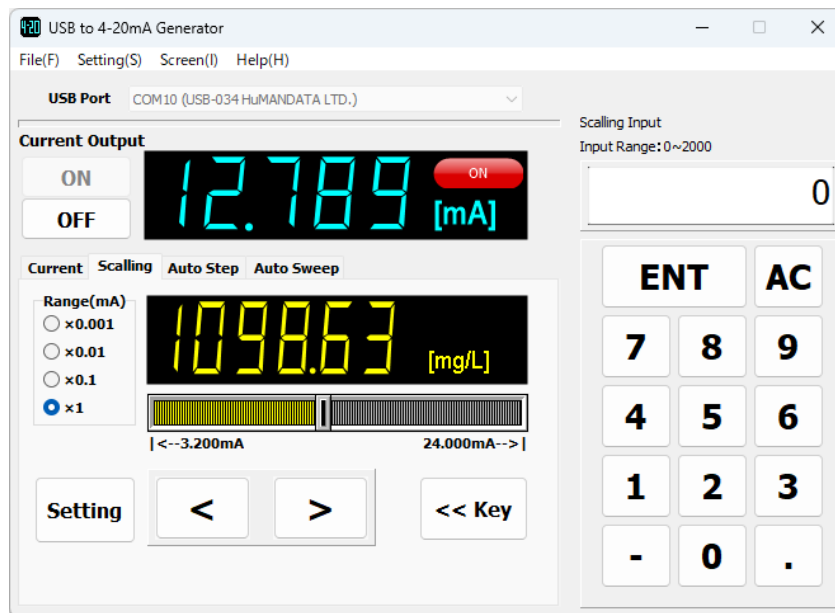

6. Additional Documentation and User Support

The following documents and other supports are available at

<https://www.hdl.co.jp/en/faspc/USB/usb-034>

- | Dedicated Application (USB to 4-20 mA Generator)
 - | User's Manual
 - | Outline Drawing
 - | Device Driver
- ... and more.

7. Warranty and Compensation

Please refer to the following URL for the warranty.

<https://www.fa.hdl.co.jp/en/fa-warranty.html>

USB to 4-20mA Generator

USB-034 Rev2

User's Manual

Ver. 1.0Apr. 22, 2026

HuMANDATA LTD.

Address: 1-2-10-2F, Nakahozumi, Ibaraki
Osaka, Japan
ZIP 567-0034

Tel: 81-72-620-2002 (Japanese)

Fax: 81-72-620-2003 (Japanese/English)

URL: <https://www.fa.hdl.co.jp/en/> (Global)

<https://www.fa.hdl.co.jp> (Japan)
