



USB Isolator Compact

USB-029L (Rev3)

User's Manual

Ver. 2.0

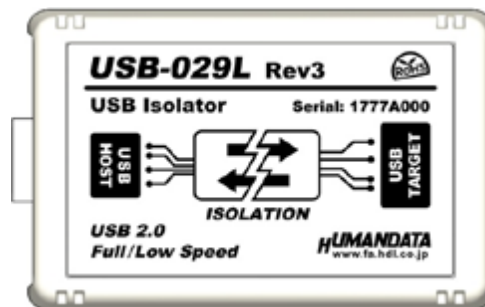



HUMANDATA LTD.

Table of Contents

● Precautions	1
● Revision History	2
● Introduction	2
1. Overview	3
2. Feature	4
3. Connection	4
4. Power Supply	4
5. Specifications	5
5.1. Product Specification	5
6. Additional Documentation and User Support	6
7. Warranty and Compensation.....	6

● Precautions

 Do Not	1	This product uses ordinary off-the-shelf electronic components, and is therefore inappropriate for use in applications that require special quality or reliability and are expected to protect human lives or prevent accidents, such as safety mechanisms in fields including space, aeronautics, medicine, and nuclear power.
	2	Do not be used underwater or in high-humidity environments.
	3	Do not be used in the presence of corrosive gases, combustible gases, or other flammable gases.
	4	Do not turn on power when circuit board surface is in contact with other metal.
	5	Do not apply voltage higher than rated voltage.

 Attention	6	This manual may be revised in the future without notice owing to improvements.
	7	All efforts have been made to produce the best manual possible, but if users notice an error or other problem, we ask that they notify us.
	8	Item 7 notwithstanding, HuMANDATA cannot be held liable for the consequences arising from use of this product.
	9	HuMANDATA cannot be held liable for consequences arising from using this product in a way different from the uses described herein, or from uses not shown herein.
	10	This manual, circuit diagrams, sample circuits, and other content may not be copied, reproduced, or distributed without permission.
	11	If the product emits smoke, catches fire, or becomes unusually hot, cut the power immediately.
	12	Do not install the control cables or communication cables together with the main circuit lines or power cables. In such an environment, it may result in malfunction due to noise.
	13	Be careful of static electricity.

- **Revision History**

Date	Revision	Description
Apr. 11, 2017	v2.0	Upgrade product version to Rev 3.

- **Introduction**

Thank you very much for purchasing our product USB-029L.

USB-029L is a USB 2.0 Full Speed (12Mbps) and Low Speed (1.5Mbps) compliant isolator that isolates between a USB host and a USB peripheral device.

1. Overview

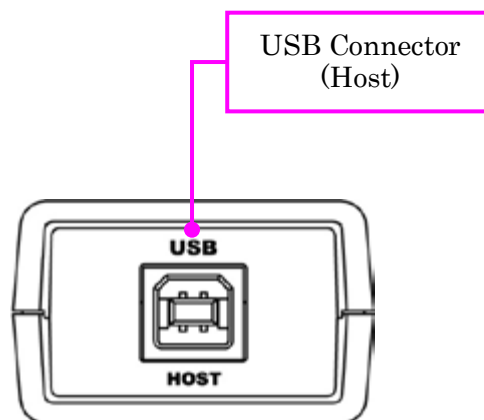

USB Host side

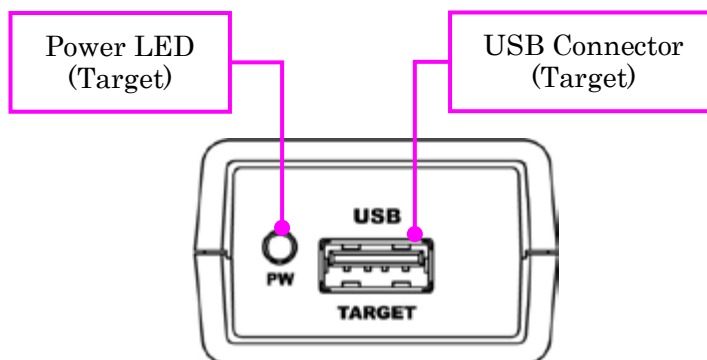

USB Target side

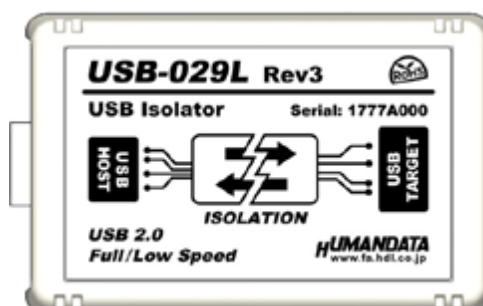

TOP side

2. Feature

USB-029L is a USB 2.0 Full Speed (12Mbps) and Low Speed (1.5Mbps) compliant isolator which isolates between a USB host and a USB peripheral device.

With USB-029L, it can be expected to eliminate ground loops that can cause measurement errors and equipment from surges, common-mode voltage, static discharge, magnetic fields, and radio frequency interference.

There is no need to install any drivers. It works with every operating system such as Windows, Linux, Mac OS X.

3. Connection

You can use an included USB cable to the host side connector to the host (such as a personal computer), and connect a USB peripheral device to the target side connector.

4. Power Supply

USB-029L is powered through a USB port (Bus-powered).

5. Specifications

5.1. Product Specification

Item	Description	Remarks
Model	USB-029L	
Input Power	5VDC Supplied through a USB port (Bus-powered)	No external power supply required
Current Consumption	Less than 100mA + current of the target device	Target device: 400mA max. (Lower than the supply capacity of the host side)
HOST interface	USB 2.0 Compliant (Supports Full and Low Speed)	USB 1.1 compatible High Speed is not supported ESD protection
Isolation Method	Bus isolation	
Isolation Protection	2500VDC	Designed value
Support OS	OS-Independent (No drivers required)	
LED	PW: Power	
Operating Ambient Temperature	-20 to 60 [°C] (-4 to 140 [°F])	No condensation permitted
Operating Ambient Humidity	30 to 85%RH	
Storage Ambient Temperature	-20 to 60 [°C] (-4 to 140 [°F])	
Storage Ambient Humidity	30 to 85%RH	
Weight	Approx. 50 [g]	Only main body
Dimensions	67 x 43.5 x 27 [mm] (2.638" x 1.713" x 1.063")	Without projections

6. Additional Documentation and User Support

The following documents and other supports are available at

<http://www.hdl.co.jp/en/faspc/USB/usb-029l>

- User's Manual
- Outline drawing
- ... and more.

7. Warranty and Compensation

Please refer to the following URL for the warranty.

<http://www.fa.hdl.co.jp/en/fa-warranty.html>

USB Isolator Compact

USB-029L Rev3

User's Manual

Ver. 2.0Apr. 11, 2017

HuMANDATA LTD.

Address: 1-2-10-2F, Nakahozumi, Ibaraki
Osaka, Japan
ZIP 567-0034

Tel: 81-72-620-2002 (Japanese)

Fax: 81-72-620-2003 (Japanese/English)

URL: <http://www.fa.hdl.co.jp> (Japan)

<http://www.fa.hdl.co.jp/en> (Global)
