

LAN Multiplexer 2:1 x 2CH



LNX-205

User's Manual

Ver. 1.1

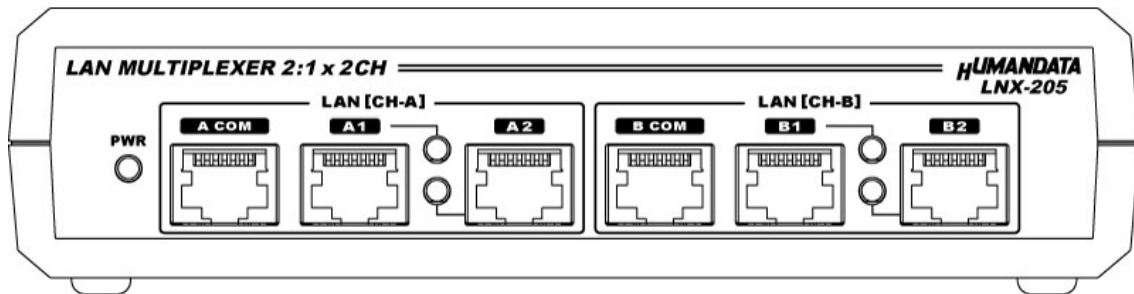



Table of Contents

| | |
|--|----|
| ● Precautions | 2 |
| ● Revision History..... | 1 |
| ● Introduction | 1 |
| 1. Product Configuration | 1 |
| 2. Product Summary | 2 |
| 3. Overview | 2 |
| 3.1. Block Diagram | 2 |
| 3.2. Front Side..... | 3 |
| 3.3. Rear Side | 4 |
| 4. Specifications | 5 |
| 4.1. AC adapter (Japan's specifications) | 6 |
| 4.2. Optional Accessories..... | 6 |
| 4.3. Power Supply | 7 |
| 4.4. FG Terminal..... | 7 |
| 4.5. Selecting Switch..... | 7 |
| 5. External Contact Connector | 8 |
| 6. Connection examples | 9 |
| 7. Setting Tool | 10 |
| 7.1. Access Flow of microSD card | 11 |
| 7.2. Function | 12 |
| 7.3. Write Setting Data..... | 17 |
| 7.4. Read Setting Data | 19 |
| 7.5. Write or Read setting data over the network | 21 |
| 8. Controller Command..... | 22 |
| 9. Virtual COM Port..... | 25 |
| 10. Additional Documentation and User Support | 26 |
| 11. Warranty and Compensation..... | 26 |

● **Precautions**

| | | |
|--|---|---|
|  Do Not | 1 | This product uses ordinary off-the-shelf electronic components, and is therefore inappropriate for use in applications that require special quality or reliability and are expected to protect human lives or prevent accidents, such as safety mechanisms in fields including space, aeronautics, medicine, and nuclear power. |
| | 2 | Do not be used underwater or in high-humidity environments. |
| | 3 | Do not be used in the presence of corrosive gases, combustible gases, or other flammable gases. |
| | 4 | Do not turn on power when circuit board surface is in contact with other metal. |
| | 5 | Do not apply voltage higher than rated voltage. |

| | | |
|---|----|--|
|  Attention | 6 | This manual may be revised in the future without notice owing to improvements. |
| | 7 | All efforts have been made to produce the best manual possible, but if users notice an error or other problem, we ask that they notify us. |
| | 8 | Item 7 notwithstanding, HuMANDATA cannot be held liable for the consequences arising from use of this product. |
| | 9 | HuMANDATA cannot be held liable for consequences arising from using this product in a way different from the uses described herein, or from uses not shown herein. |
| | 10 | This manual, circuit diagrams, sample circuits, and other content may not be copied, reproduced, or distributed without permission. |
| | 11 | If the product emits smoke, catches fire, or becomes unusually hot, cut the power immediately. |
| | 12 | Do not install the control cables or communication cables together with the main circuit lines or power cables. In such an environment, it may result in malfunction due to noise. |
| | 13 | Be careful of static electricity. |

● Revision History

| Date | Revision | Description |
|------------------|----------|--|
| August 30, 2021 | v1.0 | Initial release |
| February 5, 2026 | v1.1 | Change: Specifications of AC adaptor Update: 4.2.Optional Accessories |

● Introduction

Thank you very much for purchasing our product LNX-205.

LNX-205 is a LAN multiplexer to switch 2 LAN ports of 2 individual channels.

1. Product Configuration

The following lists the product configuration of the LNX-205.

| | |
|--|---|
| LAN multiplexer (LNX-205) | 1 |
| microSD card with USB adapter | 1 |
| D-Sub 9pin M2.6 screw (#4-40 UNC is mounted) | 2 |
| AC adapter (DC5V) | 1 |
| Driver & Application CD | 1 |

2. Product Summary

LNX-205 is a LAN multiplexer to switch 2 LAN ports of 2 individual channels. LNX-205 can change the LAN port by three ways: send simple command from PC via LAN, input control signal from an external no-voltage contact (dry contact) or change switches of the product body. This is very useful to switch external network to internal network, and to connect with the network only when required. It can promote labor-saving for inspection process and auto-inspection system of LAN devices.

LNX-205 supports PoE. That makes it possible to be powered via a LAN cable (PoE compatible HUB or other is required). It can also be powered by the AC adapter. Network setting can be saved to and restored from a microSD card. Restoring the setting information from a microSD card is very convenient when replacing LNX-205.

3. Overview

3.1. Block Diagram

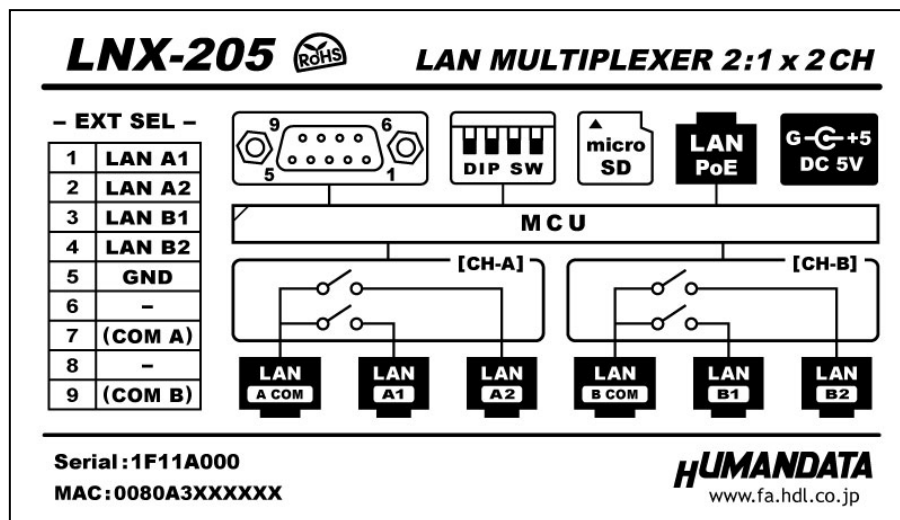

3.2. Front Side

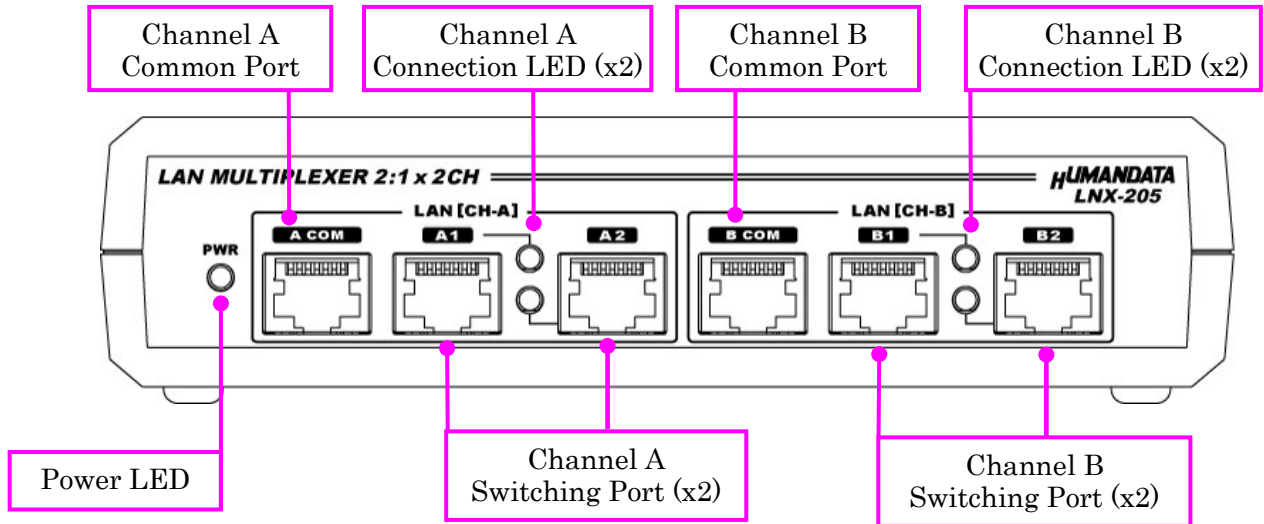

LEDs

| | Name (color) | Function |
|-----------------------|----------------------|--|
| PWR | Power LED (red) | Turn on during the power is supplied. |
| LAN A1, A2, B1, B2 | Connection LED (red) | Turn on during connecting with channel A or B common Port. |

3.3. Rear Side

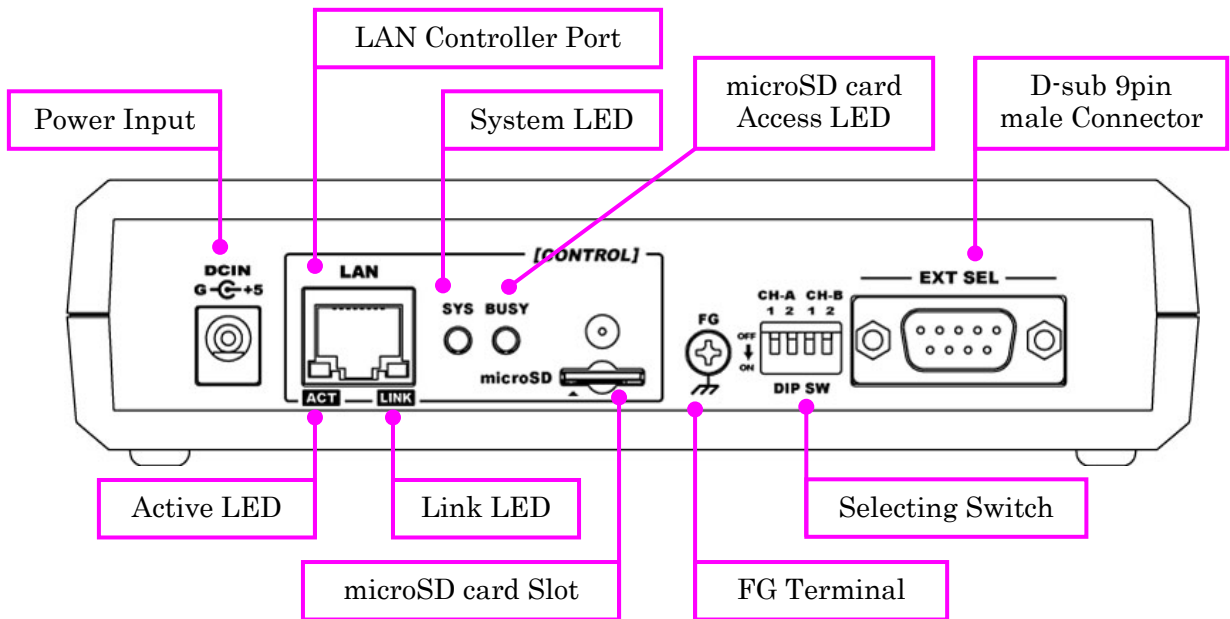

LEDs

| | Name (color) | Function |
|------|-------------------------------|---|
| ACT | Active LED (green) | Turn on during network port communication. |
| LINK | Link LED (yellow) | Turn on when the power is supplied and LAN cable is connected normally. |
| SYS | System LED (red) | Blink few seconds during reading process. Turn on when system is ready. |
| BUSY | microSD card access LED (red) | Turn on during accessing microSD card. When it turned off, you can extract the card. |

4. Specifications

| Item | Description | Remarks |
|-------------------------|---|---|
| Model | LNX-205 | |
| Power | 5VDC, Supplied by AC adapter or LAN connector (PoE function) | PoE function supports both mode A and B |
| Current Consumption | Less than 300mA | |
| Network Interface | IEEE802.3 (10Base-T) IEEE802.3u (100Base-TX) half-duplex / full-duplex (auto detected) | |
| Common/Switching Port | 10/100/1000 Base-T *1 | |
| Switching Port Number | 2 port x 2 channel | |
| LAN Connector | RJ45 x 7 | ESD protection ±11KV |
| Protocol | TCP / UDP / Telnet | |
| RS-232C Connector | D-Sub 9pin Male (#4-40 UNC screws are mounted) | M2.6 screws are also attached for accessory |
| Setting Memory Card | microSD card | For save and restore the product setting SPI mode |
| LED | Power LED, Connection LED x 4 System LED, microSD card access LED LINK Status LED (RJ45 Connector) ACT Status LED (RJ45 Connector) | |
| Operating Ambient Temp. | -20 to 60 [°C] (-4 to 140 [°F]) | No condensation permitted |
| Operating Ambient Hum. | 10 to 85 %RH | |
| Storage Ambient Temp. | -20 to 60 [°C] (-4 to 140 [°F]) | |
| Storage Ambient Hum. | 10 to 85 %RH | |
| Weight | Approx. 250 [g] | Only main body |
| Dimensions | 165 x 80.5 x 39 [mm] (6.496" x 3.169" x 1.535") | Without projections |

*1 The operation of this product is confirmed with 10/100/100 BASE-T. But the product is inserted between LAN cables, speed reduction can be occurred. The communication speed is not guaranteed. When the LAN cable is long, using giga bit corresponding switching hub may improve the speed reduction.

* There may be cases that these parts and specifications are changed.

* Power saving function (suspend, standby, sleep and others) is not supported

* Please use the microSD card that is included in the package.





4.1. AC adapter (Japan's specifications)

| Item | Description | Remarks |
|-------------------------|---|---------------------------|
| Input | AC100 to 240V, 50/60Hz 0.45A | |
| Output | 5VDC 2.0A | |
| Plug | 2.1mm inner diameter | Positive Tip |
| Compatible DC Jack | 2.1mm inner diameter | |
| Operating Ambient Temp. | 0 to 40 [°C] (32 to 104 [°F]) | No condensation permitted |
| Operating Ambient Hum. | 10 to 90 %RH | |
| Storage Ambient Temp. | -20 to 80 [°C] (-4 to 176 [°F]) | |
| Storage Ambient Hum. | 5 to 95 %RH | |
| Wire Length | 1.6m | |
| Weight | approx. 70 [g] | |
| Dimensions | 46 x 37 x 22 [mm] 1.811" x 1.457" x 0.866" | Without projections |

* This AC adapter is attached for use mainly in Japan. If you use in the other countries, please check the specifications above and plug shape.

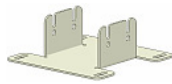
* There may be cases that this part and specifications are changed.

4.2. Optional Accessories

| Model Name | Image | Description |
|------------|---|---|
| ACC-027 |  | Attachment for vertical direction JAN: 4937920801096 |
| ACC-028 |  | Attachment for horizontal direction JAN: 4937920801102 |
| ACC-048 |  | Attachment for DIN rail type B JAN: 4937920801829 |
| ACC-036 |  | Neodymium magnet set JAN: 4937920801539 |

4.3. Power Supply

LNX-205 supports PoE function both A and B type as standard which make it possible to be powered via a LAN cable (PoE compatible HUB is required). It also can be powered by the AC adapter.

4.4. FG Terminal

Please connect FG terminal with earth ground as necessary.



4.5. Selecting Switch

You can change the LAN port manually by setting selecting switch. When power on, the setting is recognized as the default port setting.

If sending changing port command after setting this switch, the command is prior.

External contact point is also prior to this switch.

When you need to disable the selecting switch, set all the switches to ON.

| Select No Port | Select A1 | Select A2 | Select B1 | Select B2 |
|---|--|--|--|--|
| <p>CH-A CH-B 1 2 1 2</p> <p>DIP SW</p> <p>Factory Setting</p> | <p>CH-A CH-B 1 2 1 2</p> <p>DIP SW</p> | <p>CH-A CH-B 1 2 1 2</p> <p>DIP SW</p> | <p>CH-A CH-B 1 2 1 2</p> <p>DIP SW</p> | <p>CH-A CH-B 1 2 1 2</p> <p>DIP SW</p> |

5. External Contact Connector

D-sub 9 pin connector is mounted as external contact. When LAN A1-B2 is shorted with GND, the LAN port is switched.

e.g. Short LAN B1 (pin no. 3) with GND (pin no.5): channel B common port (B COM) and channel B switching port (B1) is connected.

Notice

To prevent the damage, for LAN A1 to B2 please use no-voltage contact (dry contact) like relay contact or switches.

| Pin No | Name | Direction | Remarks |
|--------|---------|-----------|---------------------------|
| 1 | LAN A1 | IN | Select LAN A1 |
| 2 | LAN A2 | IN | Select LAN A2 |
| 3 | LAN B1 | IN | Select LAN B1 |
| 4 | LAN B2 | IN | Select LAN B2 |
| 5 | GND | - | GND |
| 6 | NC | - | - |
| 7 | (COM A) | - | CH-A Power Input (option) |
| 8 | NC | - | - |
| 9 | (COM B) | - | CH-B Power Input (option) |
| CASE | FG | - | Connect with FG Terminal |

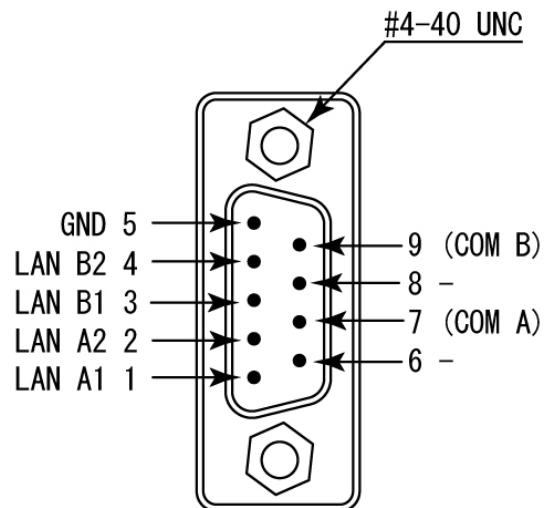

D-Sub 9pin Male

* #4-40 UNC screws are mounted by factory setting. You can change them to attached M2.6 screws.

* COM A (pin No.7), COM B (pin No.9) is an option for DC 5V to 24V power input. If you need to change LAN port directly from open collector or transistor, please contact us.

6. Connection examples

Change common port LAN or external network to LAN1 or LAN2. Channel A and B is independent from each other.

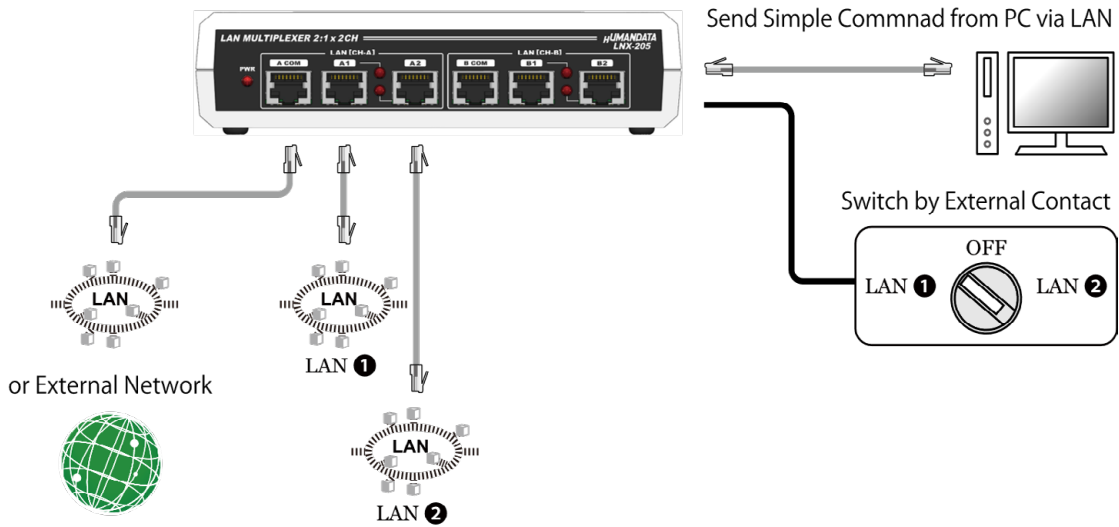

7. Setting Tool

Setting tool supports to save and read network setting by a microSD card. This tool does not require installation.

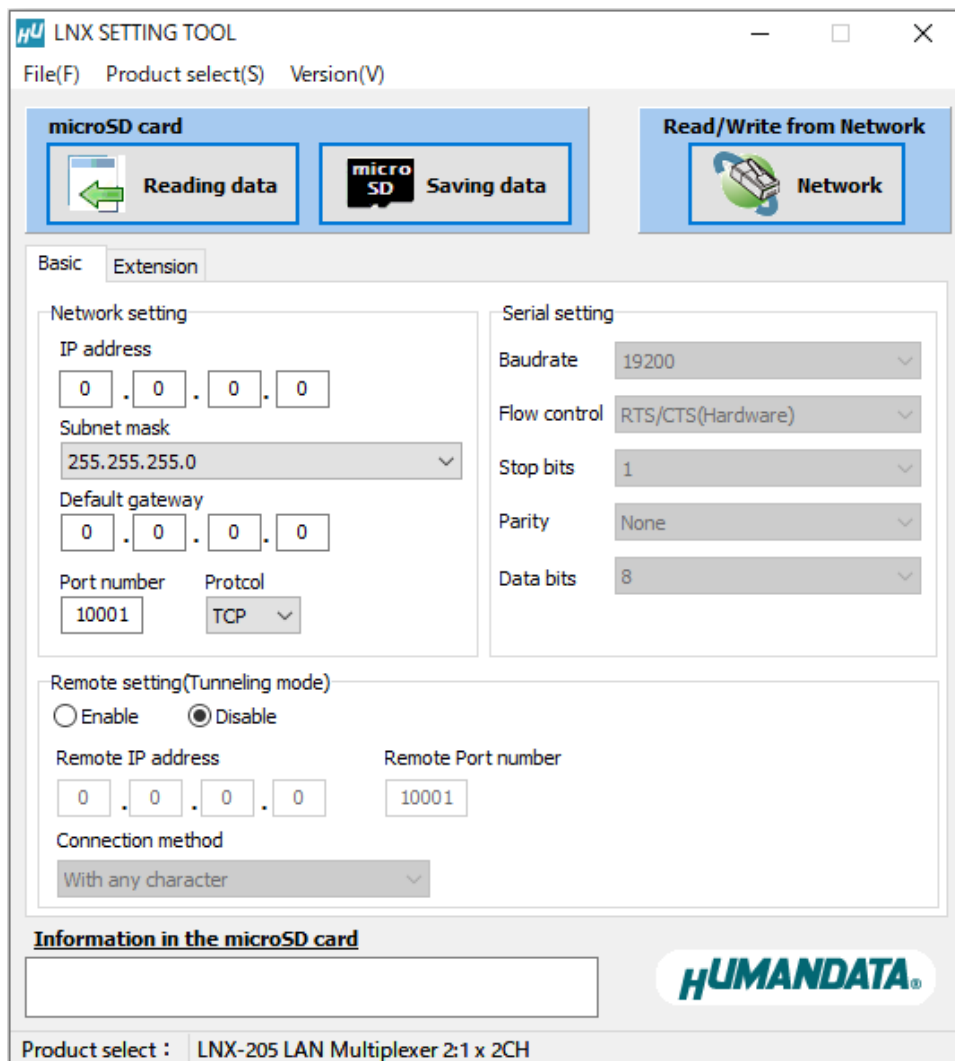

This is a screenshot from version 2.8

7.1. Access Flow of microSD card

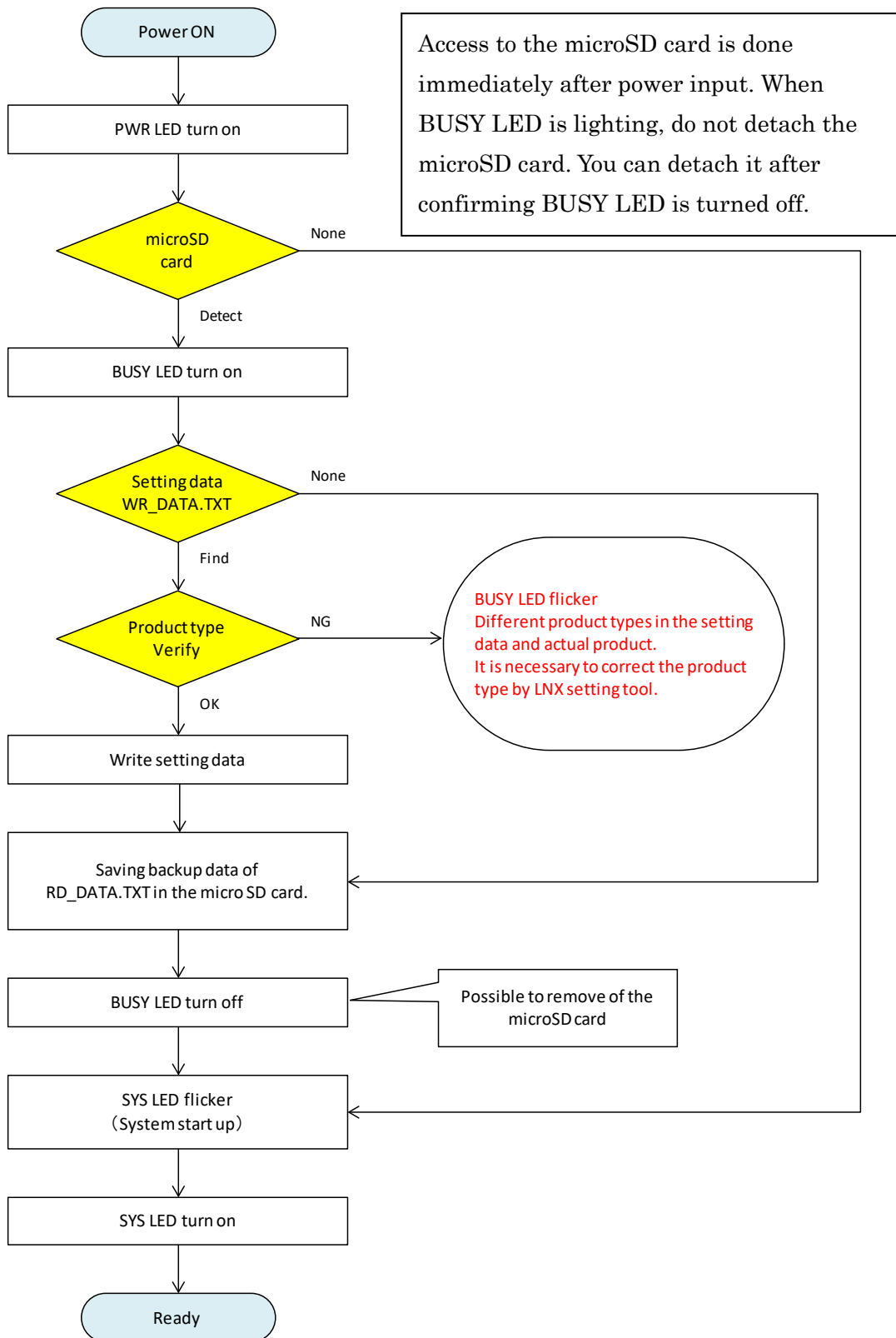

7.2. Function

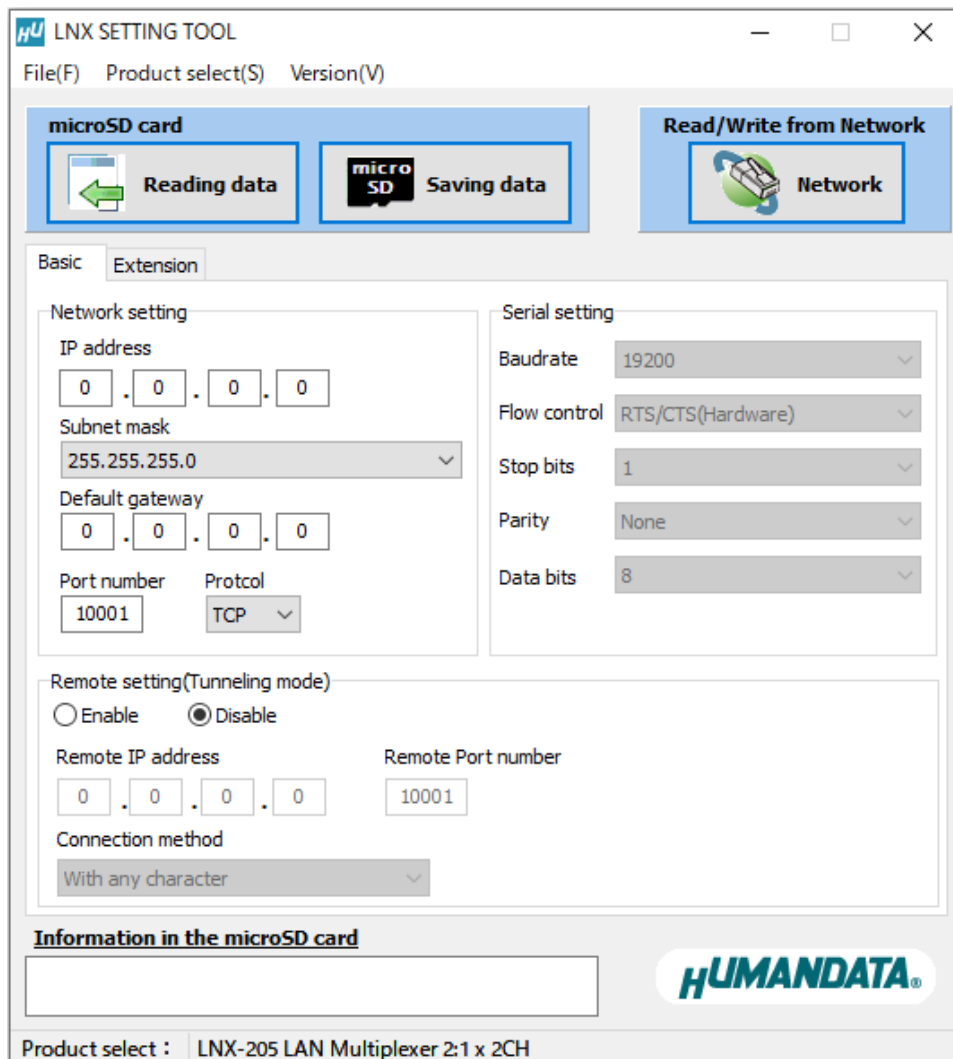

| Item | Contents |
|---------------------------------|--|
| Reading data | Read setting data (RD_DATA.txt) from microSD card. |
| Saving data | Save setting data (WR_DATA.txt) to microSD card. |
| Network | Read or write setting data over the network. LNX product and PC must be connected to the same network segment. |
| Product select(S) | Display product select window. |
| File(F) -> Copy to clipboard | Copy a display image to clipboard. |
| File(F) -> Exit | Terminate the application. |
| Version(V) | Display application version. |

[Basic Setting]

| Item | Contents | | | | | | | | | | |
|------------------------|--|--------|-------------------------------|------|---------------------------|-------------|-----------------------------|-------|--|-------|----------------------------|
| IP address | If DHCP is not used to assign an IP address, enter it manually. Unique IP address must be used in the network. The default setting is 0.0.0.0 (DHCP is enabled) | | | | | | | | | | |
| Subnet mask | A subnet mask defines the number of bits taken from the IP address that are assigned for the host part. | | | | | | | | | | |
| Default gateway | A gateway address of a router which is allowed to communicate to other LAN segments. This address should be an IP address of the router which is in the same LAN segment. | | | | | | | | | | |
| Port number | <p>Enter the local port number. The default setting is 10001. If you change the value, please avoid the following numbers. They are allocated to other function.</p> <table border="1" style="width: 100%; border-collapse: collapse;"> <tbody> <tr> <td style="width: 30%;">1-1024</td> <td>Reserved for well-known ports</td> </tr> <tr> <td>9999</td> <td>Reserved for telnet setup</td> </tr> <tr> <td>14000-14009</td> <td>Reserved for old redirector</td> </tr> <tr> <td>30704</td> <td>Reserved for remote control of user I/Os</td> </tr> <tr> <td>30718</td> <td>Reserved for configuration</td> </tr> </tbody> </table> | 1-1024 | Reserved for well-known ports | 9999 | Reserved for telnet setup | 14000-14009 | Reserved for old redirector | 30704 | Reserved for remote control of user I/Os | 30718 | Reserved for configuration |
| 1-1024 | Reserved for well-known ports | | | | | | | | | | |
| 9999 | Reserved for telnet setup | | | | | | | | | | |
| 14000-14009 | Reserved for old redirector | | | | | | | | | | |
| 30704 | Reserved for remote control of user I/Os | | | | | | | | | | |
| 30718 | Reserved for configuration | | | | | | | | | | |

| | |
|---|--|
| Protocol | From the drop-down menu, select TCP or UDP. Normally TCP is used, but when one-to-multiple communication like broadcast or sensitive-responsiveness is needed, please select UDP. The default setting is TCP. |
| Remote Setting (Tunneling mode) Enable/Disable | Select to enable remote connection (tunneling). The default setting is disable. |
| Remote IP address | Enter the remote IP address of tunneling target. |
| Remote Port number | Enter the remote port number of tunneling target. |
| Connection method | Select connection method to the target. |

* Serial setting of LNX-205 is fixed.

[Extension]

| Item | Contents |
|------------------------------------|---|
| Pack control Enable/Disable | <p>Select to enable pack control.</p> <p>Two packing algorithms define how and when packets are sent to the network. The standard algorithm is optimized for applications in which the unit is used in a local environment, allowing for very small delays for single characters, while keeping the packet count low. The alternate packing algorithm minimizes the packet count on the network and is especially useful in applications in a routed Wide Area Network (WAN). Adjusting parameters in this mode can economize the network data stream.</p> <p>The default setting is disable.</p> |
| Idle gap time | <p>Select idle gap time from 12, 52, 250 or 5000 msec.</p> <p>After this idle gap time with no response from a serial device, data is packetized and transmitted to the target. The default setting is 12.</p> |
| Trigger character | <p>Select packet size and set trigger character (hexadecimal digits).</p> |
| Check sum | <p>Select check sum size.</p> |

| | |
|---|---|
| <p>TCP keepalive</p> | <p>TCP keepalive time defines how many seconds LNX-205 waits during an inactive connection before checking its status. If the unit does not receive a response 7 consecutive times, it drops that connection. Enter a value between 0 and 65 seconds. 0 disables keepalive.</p> <p>The default setting is 5.</p> |
| <p>Telnet Com port control (RFC2217)</p> | <p>Set to enable when control COM port using Telnet.</p> <p>The product enables a RFC2217 function to use a control signal used in a serial port on a network. When it is not used this function, set to disable.</p> |
| <p>I/O buffer clear setting</p> | <p>Set it whether input/output buffer clear at the time of network connection or disconnection.</p> |
| <p>Password setting</p> | <p>If you set a password for TCP connection, you must enter the password before connecting. If you set a configuration password, you can restrict access to the setting screen that is displayed by entering the IP address from the browser.</p> <p>TCP connection: half-width characters (up to 15 characters) Configuration: half-width characters (up to 16 characters)</p> <p>*Password is not read even if [Reading Data] or [Read from Network] is performed with this tool.</p> <p>* Password setting supported in product version 1.2 or later.</p> |

7.3. Write Setting Data

1. Open Setting Tool for LNX series (LNX SETTING TOOL Ver*.*)
2. Select “LNX-205 LAN Multiplexer 2:1 x 2CH”, and click “OK”.

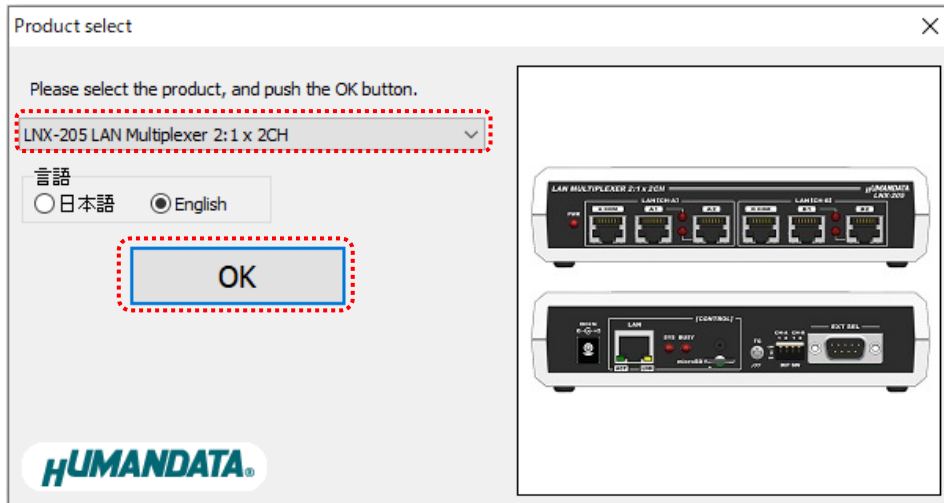

3. Enter the setting such as network or serial.
4. Insert a microSD card to PC (A USB adapter is included with the product)
5. Click “Saving data”.

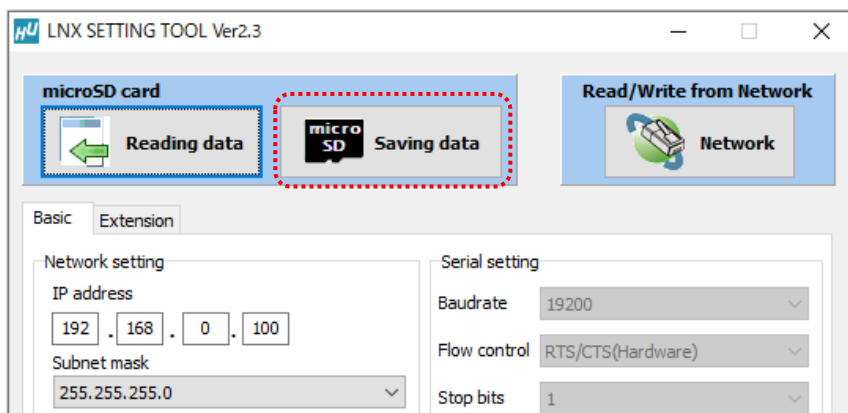

6. Click “OK” in the confirmation dialog.

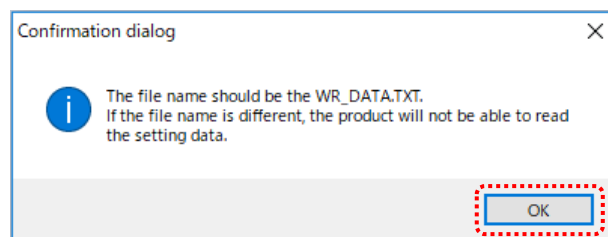

7. Specify the microSD card as saving destination. Please do not change the file name from “WR_DATA.TXT”.
8. Remove the microSD card from PC and insert it to the product. Please confirm that the product power is turned off.
9. When the product is powered on, the setting data is configured to the product automatically. After the data is stored in the product, microSD card is not needed any more. The start-up time can be shortened if the microSD card is removed from the product.

Please be careful not to detach the microSD card before BUSY LED is turned off.

7.4. Read Setting Data

1. After confirming the power is off, insert the microSD card to the product.
2. When the product is powered on, the setting data will be reserved to the microSD card automatically. The data file name is “RD_DATA.TXT”.

Please be careful not to detach the microSD card before BUSY LED is turned off.

* If there is the same file name in the microSD card, the data will be overwritten.

3. Insert a microSD card to PC (A USB adapter is included with the product)
4. Start the setting tool and click “Reading data”.

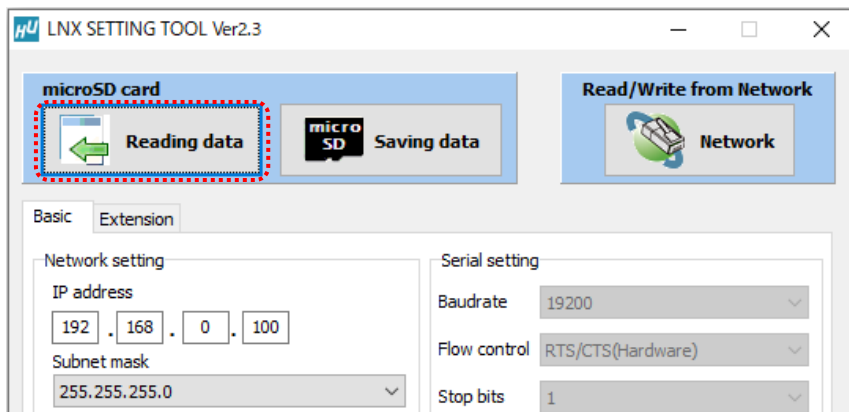

5. Click “OK” in the confirmation dialog.

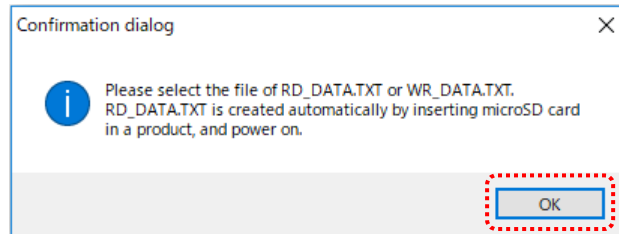

6. Open the “RD_DATA.TXT” in the microSD card.

7. Setting data is loaded.

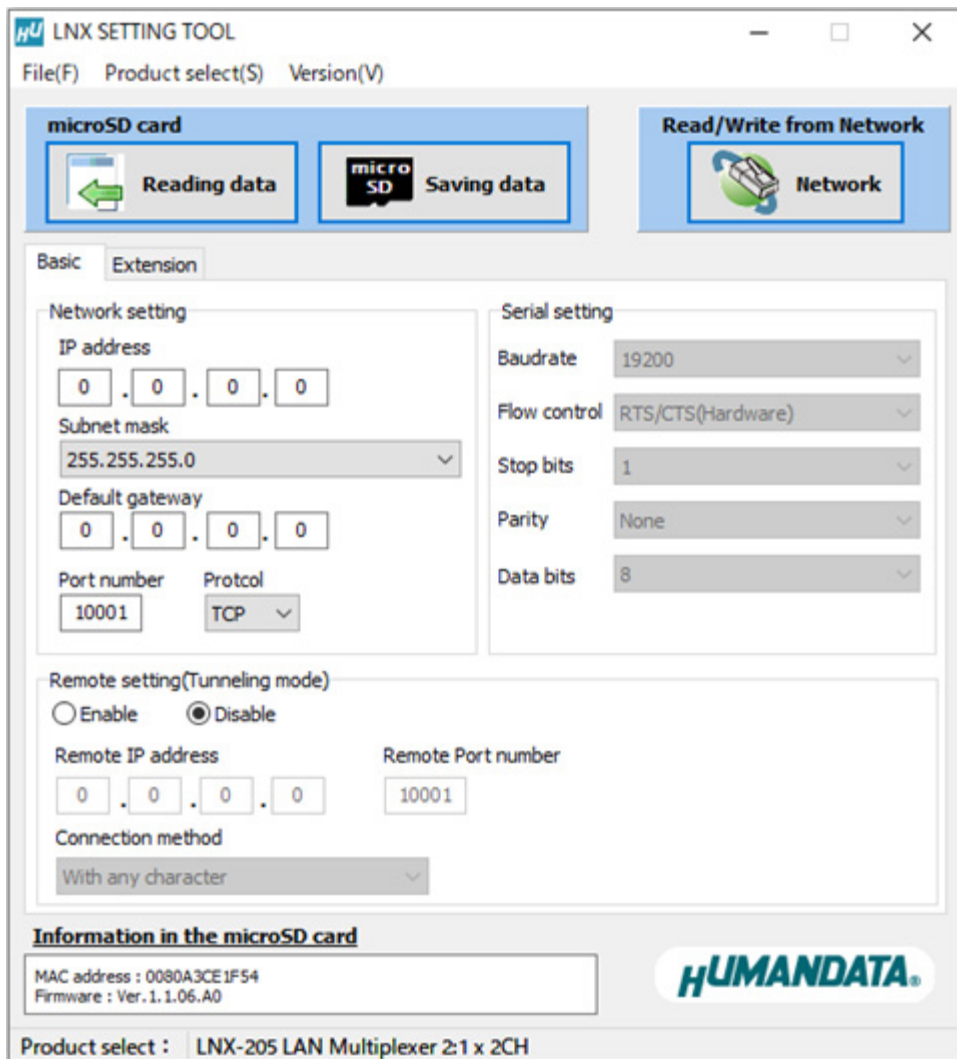

7.5. Write or Read setting data over the network

1. Enter the setting such as network or serial and click “Network”.
 - * Please confirm that microSD card is not inserted in a product.

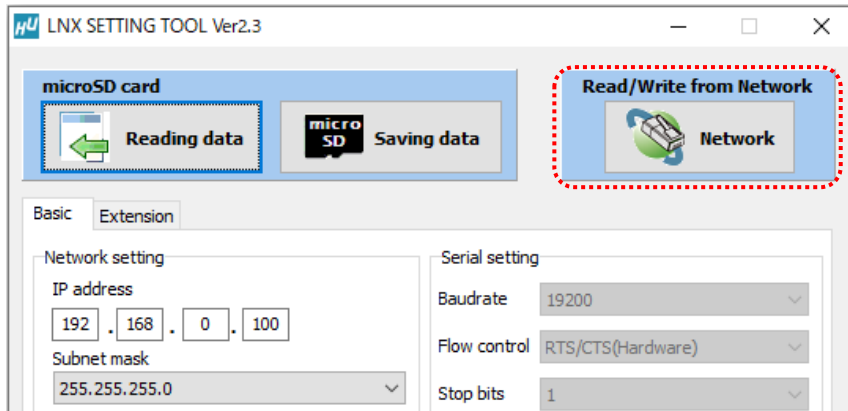

2. Enter an IP address manually or click “Search”. When some products are found, please select a number from a list.

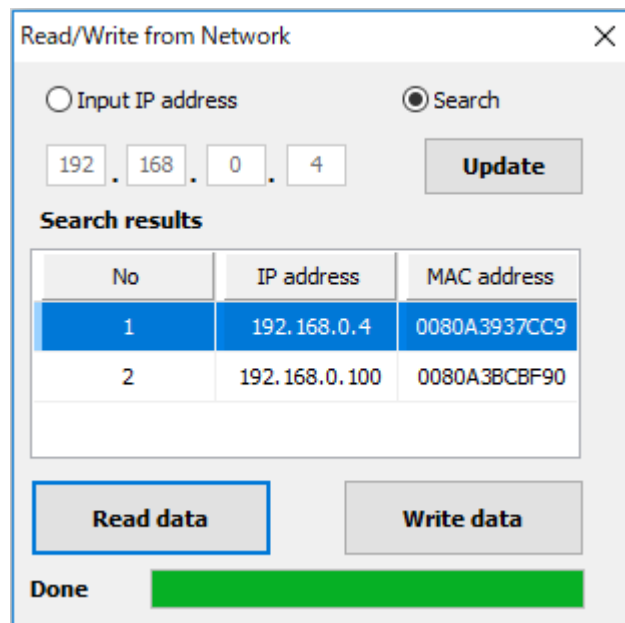

3. Click “Read data” or “Write data”
 - * Even if some devices will be listed in the list and occur process time out. In this case, please change the PCs’ network setting to the same network segment as the product or using microSD card.

8. Controller Command

You can control with simple single character command shown in the following table by using terminal software and keyboard. Each controller command is an ASCII text. The command is case sensitive.

| | Command | Function | Format |
|----|---------|-----------------------------------|------------------------|
| 1 | 'A0' | Deselect Ch.A LAN port | A0<CR> |
| 2 | 'A1' | Select Ch.A LAN port 1 | A1<CR> |
| 3 | 'A2' | Select Ch.A LAN port 2 | A2<CR> |
| 4 | 'AP' | Get active Ch.A LAN port | AP<CR> |
| 5 | 'B0' | Deselect Ch.B LAN port | B0<CR> |
| 6 | 'B1' | Select Ch.B LAN port 1 | B1<CR> |
| 7 | 'B2' | Select Ch.B LAN port 2 | B2<CR> |
| 8 | 'BP' | Get active Ch.B LAN port | BP<CR> |
| 9 | 'VE' | Get product version | VE<CR> |
| 10 | 'PS' | Set a password for port selection | PS,{PRAM1},{PRAM2}<CR> |
| 11 | 'EP' | Enable port selection | EP,{PRAM}<CR> |
| 12 | 'DP' | Disable port selection | DP<CR> |

1. 'A0': Deselect Ch.A LAN port

| | | |
|---|-----------------|---|
| Format | | A0<CR> |
| Function | | Ch.A LAN port is not selected. |
| e.g. | Send | A0<CR> |
| | Response | A0,0<CR> * When no selection of Ch.A LAN port is completed. |
| Password required<CR> *When port selection is disabled. | | |

2. 'A1': Select Ch.A LAN port 1

| | | |
|---|-----------------|--|
| Format | | A1<CR> |
| Function | | Ch.A LAN port 1(A1) is selected. |
| e.g. | Send | A1<CR> |
| | Response | A1,1<CR> * When selection of Ch.A LAN port 1 is completed. |
| Password required<CR> *When port selection is disabled. | | |

3. 'A2': Select Ch.A LAN port 2

| | | |
|-----------------|-----------------|--|
| Format | | A2<CR> |
| Function | | Ch.A LAN port 2(A2) is selected. |
| e.g. | Send | A2<CR> |
| | Response | A2,2<CR> * When selection of Ch.A LAN port 2 is completed. |
| | | Password required<CR> *When port selection is disabled. |

4. 'AP': Get active Ch.A LAN port

| | | |
|-----------------|-----------------|--|
| Format | | AP<CR> |
| Function | | Get the active Ch.A LAN port. |
| e.g. | Send | AP<CR> |
| | Response | AP,1<CR> * When Ch.A LAN port 1 is selected. |

5. 'B0': Deselect Ch.B LAN port

| | | |
|-----------------|-----------------|---|
| Format | | B0<CR> |
| Function | | Ch.B LAN port is not selected. |
| e.g. | Send | B0<CR> |
| | Response | B0,0<CR> * When no selection of Ch.B LAN port is completed. |
| | | Password required<CR> *When port selection is disabled. |

6. 'B1': Select Ch.B LAN port 1

| | | |
|-----------------|-----------------|--|
| Format | | B1<CR> |
| Function | | Ch.B LAN port 1(B1) is selected. |
| e.g. | Send | B1<CR> |
| | Response | B1,1<CR> * When selection of Ch.B LAN port 1 is completed. |
| | | Password required<CR> *When port selection is disabled. |

7. 'B2': Select Ch.B LAN port 2

| | | |
|-----------------|-----------------|--|
| Format | | B2<CR> |
| Function | | Ch.B LAN port 2(B2) is selected. |
| e.g. | Send | B2<CR> |
| | Response | B2,2<CR> * When selection of Ch.B LAN port 2 is completed. |
| | | Password required<CR> *When port selection is disabled. |

8. 'BP': Get active Ch.B LAN port

| | | |
|-----------------|-----------------|--|
| Format | | BP<CR> |
| Function | | Get the active Ch.B LAN port. |
| e.g. | Send | BP<CR> |
| | Response | BP,1<CR> * When Ch.B LAN port 1 is selected. |

9. 'VE': Get product version

| | | |
|-----------------|-----------------|---|
| Format | | VE<CR> |
| Function | | Get the product version. |
| e.g. | Send | VE<CR> |
| | Response | LNX-205 Ver.1.0<CR> *When version is 1.0. |

10. 'PS': Set a password for port selection

| | | |
|------------------|-----------------|--|
| Format | | PS,{PRAM1},{PRAM2}<CR> |
| Function | | Set a password for port selection. The default password is set to "0000". After setting a password other than "0000", enable the port selection with the E command to enable the 0 to 4 command. |
| Parameter | | PRAM1: Enter the old password. half-width characters (up to 4 characters) PRAM2: Enter the new password. half-width characters (up to 4 characters) |
| e.g. | Send | PS,0000,1234<CR> *When changing the password from 0000 to 1234. |
| | Response | Password setting completed<CR> |
| | | * When password change is completed Password do not match<CR> *When password do not match. |

11. 'EP': Enable port selection

| | | |
|------------------|-----------------|---|
| Format | | EP,{PRAM}<CR> |
| Function | | Port selection is enabled. The default password is set to "0000". After setting a password other than "0000", E command is enabled. |
| Parameter | | PRAM: Enter the password. half-width characters (up to 4 characters) |
| e.g. | Send | EP,1234<CR> *When a password is set to "1234". |
| | Response | Enable LAN port control<CR> *When port selection is enabled. |
| | | Password do not match<CR> *When password do not match. |

12. 'DP': Disable port selection

| | | |
|-----------------|-----------------------------|------------------------------|
| Format | DP<CR> | |
| Function | Port selection is disabled. | |
| e.g. | Send | DP<CR> |
| | Response | Disable LAN port control<CR> |

*If the product receives an undefined command, "Undefined command<CR>" will be returned.

* <CR>: Carriage Return (0x0D)

9. Virtual COM Port

You can use the software that creates Virtual COM ports on your PC. You can use the COM port to communicate to an IP address of LNX-205.

Please refer to the "LNX series virtual COM port User's Manual" that are stored on the product supplied CD for details.

10. Additional Documentation and User Support

The following documents and other supports are available at

<https://www.hdl.co.jp/en/faspc/LNX/lrx-205>

- LNX SETTING TOOL
 - Virtual COM Port
 - Outline Drawing
- ... and more.

11. Warranty and Compensation

Please refer to the following URL for the warranty.

<https://www.fa.hdl.co.jp/en/fa-warranty.html>

LAN Multiplexer 2:1 x 2ch

LNX-205

User's Manual

Ver. 1.1 February 6, 2026

HuMANDATA LTD.

Address: 1-2-10-2F, Nakahozumi, Ibaraki
Osaka, Japan
ZIP 567-0034

Tel: 81-72-620-2002 (Japanese)

Fax: 81-72-620-2003 (Japanese/English)

URL: <https://www.fa.hdl.co.jp> (Japan)

<https://www.fa.hdl.co.jp/en/> (Global)
