

V50	V50
V33	V33
V12	V12
GND	GND

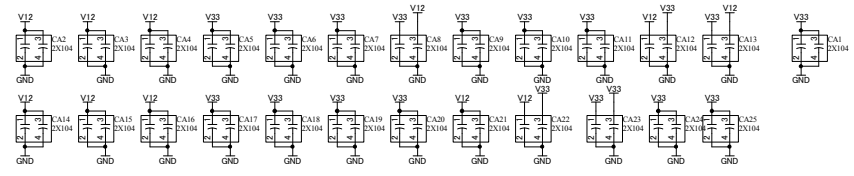

XCM019R1-SCH-A1.pdf

	2011/2/14		
	HuMANDATA LTD. OSAKA JAPAN www.hdl.co.jp/en/(Global) www.hdl.co.jp/(Japan)	SPARTAN-6 FG484 FPGA Board (5V I/F)	
Date: 14-Feb-2011 17:01:01	DOC. No. XCM-019	File: XCM019A.sch	Sheet 1 of 3

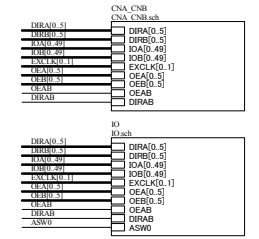
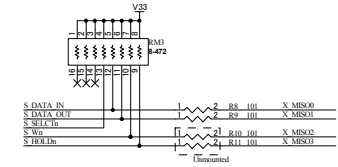
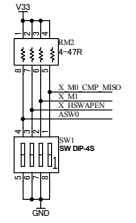
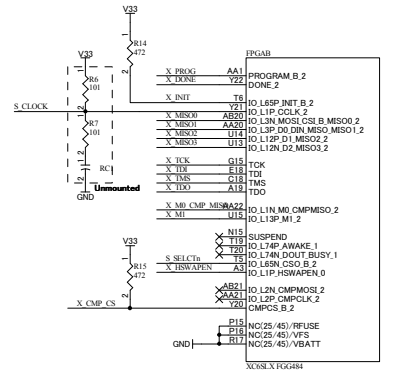
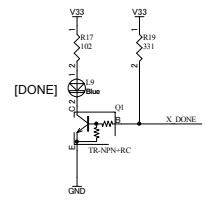
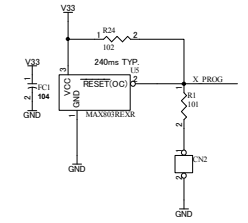
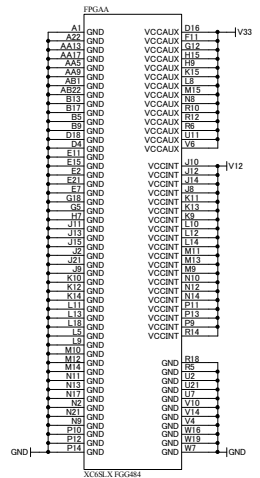
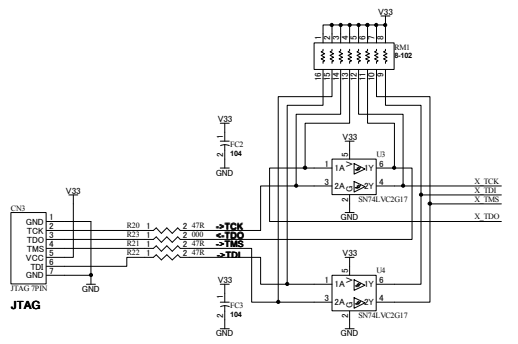
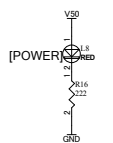
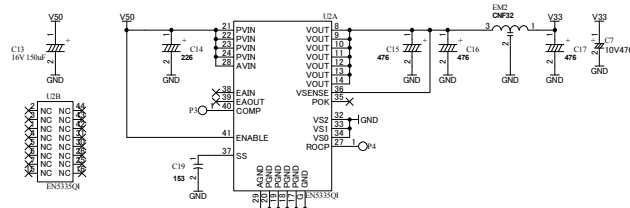
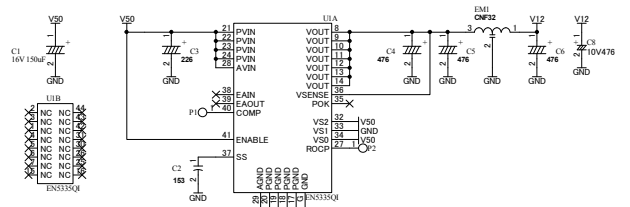
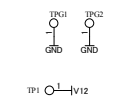