

Vaux|
V33A|
V33B|
V12|
GND|

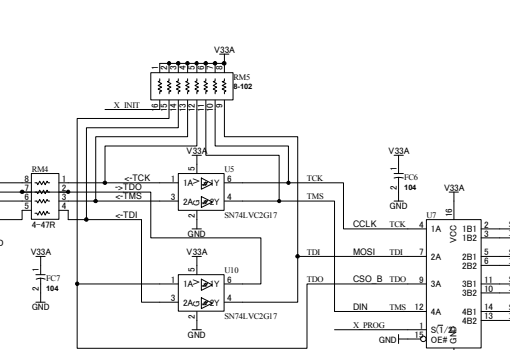

[xxx] is FPGA PIN NAME of 700/1400

A1	GND	VCCAU[VCCAUX]	E11	Vaux
A16	GND	VCCAU[VCCAUX]	F5	
A31	GND	VCCAU[VCCAUX]	F8	
A37	GND	VCCAU[VCCAUX]	F9	
G14	GND	VCCAU[VCCAUX]	M8	
G21	GND			
G12	GND			
G13	GND			
G14	GND			
G15	GND			
G16	GND			
G17	GND			
G18	GND			
G19	GND			
G20	GND			
G21	GND			
G22	GND			
G23	GND			
G24	GND			
G25	GND			
G26	GND			
G27	GND			
G28	GND			
G29	GND			
G30	GND			
G31	GND			
G32	GND			
G33	GND			
G34	GND			
G35	GND			
G36	GND			
G37	GND			
G38	GND			
G39	GND			
G40	GND			
G41	GND			
G42	GND			
G43	GND			
G44	GND			
G45	GND			
G46	GND			
G47	GND			
G48	GND			
G49	GND			
G50	GND			
G51	GND			
G52	GND			
G53	GND			
G54	GND			
G55	GND			
G56	GND			
G57	GND			
G58	GND			
G59	GND			
G60	GND			
G61	GND			
G62	GND			
G63	GND			
G64	GND			
G65	GND			
G66	GND			
G67	GND			
G68	GND			
G69	GND			
G70	GND			
G71	GND			
G72	GND			
G73	GND			
G74	GND			
G75	GND			
G76	GND			
G77	GND			
G78	GND			
G79	GND			
G80	GND			
G81	GND			
G82	GND			
G83	GND			
G84	GND			
G85	GND			
G86	GND			
G87	GND			
G88	GND			
G89	GND			
G90	GND			
G91	GND			
G92	GND			
G93	GND			
G94	GND			
G95	GND			
G96	GND			
G97	GND			
G98	GND			
G99	GND			
G100	GND			

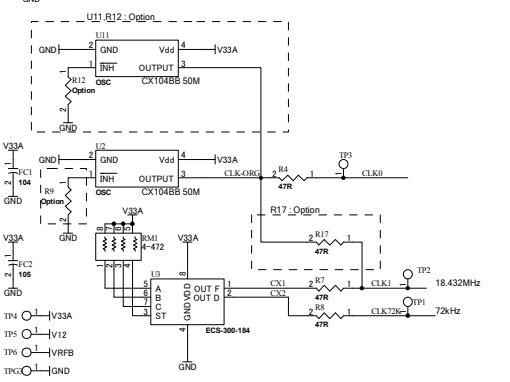
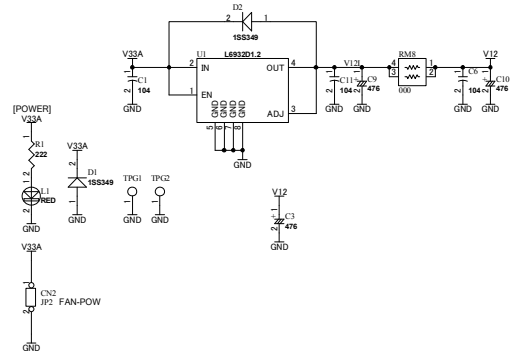
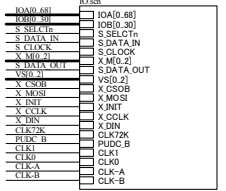
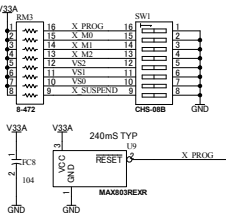
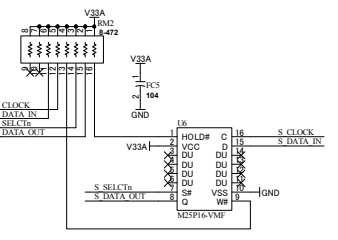
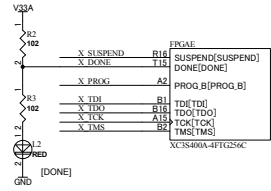
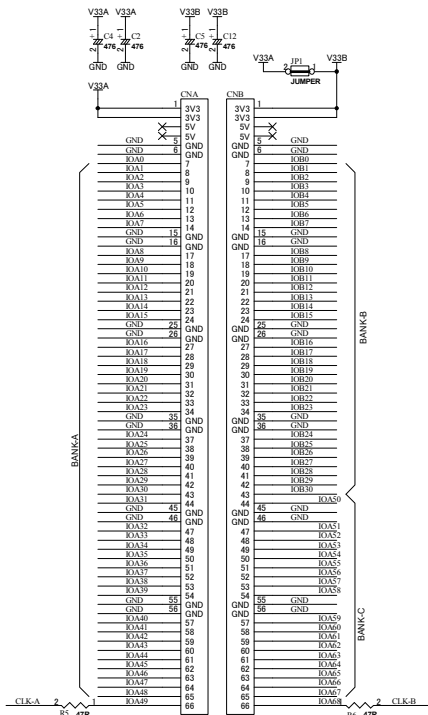
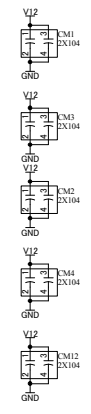

XCM014A2.sch.pdf

		HuMANDATA LTD. OSAKA JAPAN www.hdl.co.jp/en/ (Global) www.hdl.co.jp/ (Japan)		Xilinx Spartan-3A FTG256 FPGA board		DOC. No. XCM-014	A2

