

Top Overlay
Top Solder Mask

L1 : Signal Top		0.5oz
L2 : Signal mid1		0.5oz
L3 : Signal mid2		0.5oz
L4 : Signal mid3		0.5oz
L5 : GND		1oz
L6 : U33_A		1oz
L7 : Signal mid4		0.5oz
L8 : Signal mid5		0.5oz
L9 : Signal mid6		0.5oz
L10 : Signal Bottom		0.5oz

HuMANDATA LTD.	HuMANDATA	出力ファイル名
TITLE: ACM-201		ACM201C .GT9
PART NO: ACM-201C	Design: S.ushiro	
FILE NAME: ACM201C.Pcb	DATE: 4-Oct-2005	2005/10/04

有限会社ヒューマンデータ

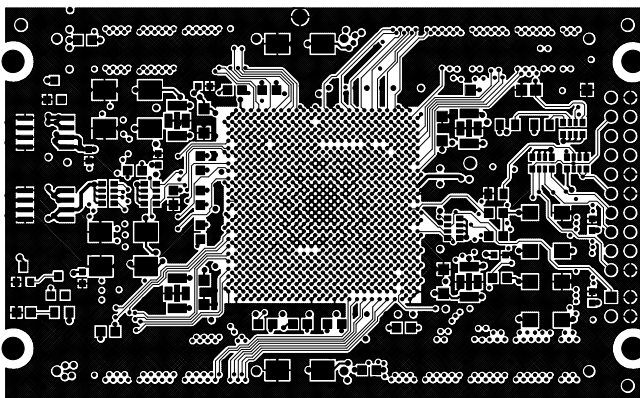

L1 : Signal Top	TopLayer	0.5oz
L2 : Signal mid1		0.5oz
L3 : Signal mid2		0.5oz
L4 : Signal mid3		0.5oz
L5 : GND		1oz
L6 : V33_A		1oz
L7 : Signal mid4		0.5oz
L8 : Signal mid5		0.5oz
L9 : Signal mid6		0.5oz
L10 : Signal Bottom		0.5oz

HuMANDATA LTD.	HuMANDATA	出カファイル名
TITLE: ACM-201		ACM201C .GTL
PART NO.: ACM-201C	Design: S.ushiro	
FILE NAME: ACM201C.Pcb	DATE: 4-Oct-2005	2005/10/04

有限会社ヒューマンデータ

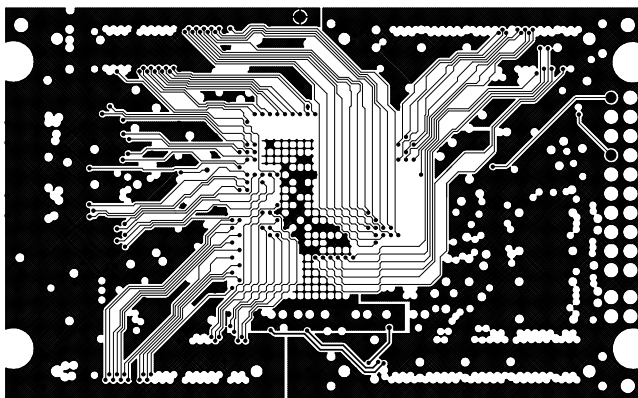

L1 : Signal Top		0.5oz
L2 : Signal mid1	MidLayer1	0.5oz
L3 : Signal mid2		0.5oz
L4 : Signal mid3		0.5oz
L5 : GND		1oz
L6 : V33_A		1oz
L7 : Signal mid4		0.5oz
L8 : Signal mid5		0.5oz
L9 : Signal mid6		0.5oz
L10 : Signal Bottom		0.5oz

HuMANDATA LTD.	HuMANDATA	出カファイル名
TITLE: ACM-201		ACM201C .G1
PART NO.: ACM-201C	Design: S.ushiro	
FILE NAME: ACM201C.Pcb	DATE: 4-Oct-2005	2005/10/04

有限会社ヒューマンデータ

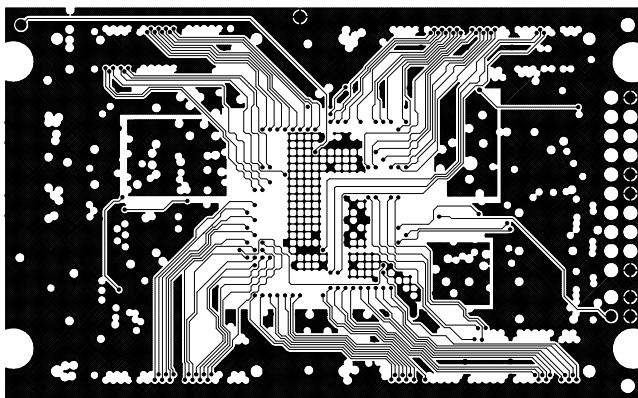

L1 : Signal Top		0.5oz
L2 : Signal mid1		0.5oz
L3 : Signal mid2	MidLayer 2	0.5oz
L4 : Signal mid3		0.5oz
L5 : GND		1oz
L6 : U33_A		1oz
L7 : Signal mid4		0.5oz
L8 : Signal mid5		0.5oz
L9 : Signal mid6		0.5oz
L10 : Signal Bottom		0.5oz

HuMANDATA LTD.	HuMANDATA	出力ファイル名
TITLE: ACM-201		ACM201C .G2
PART NO.: ACM-201C	Design: S.ushiro	
FILE NAME: ACM201C.Pcb	DATE: 4-Oct-2005	2005/10/04

有限会社ヒューマンデータ

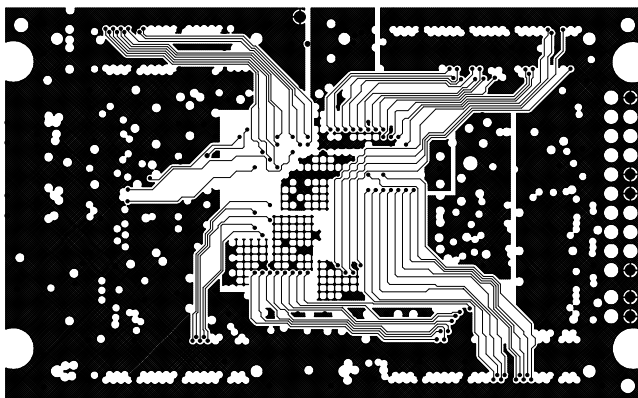

L1 : Signal Top		0.5oz
L2 : Signal mid1		0.5oz
L3 : Signal mid2		0.5oz
L4 : Signal mid3	MidLayer3	0.5oz
L5 : GND		1oz
L6 : V33_A		1oz
L7 : Signal mid4		0.5oz
L8 : Signal mid5		0.5oz
L9 : Signal mid6		0.5oz
L10 : Signal Bottom		0.5oz

HuMANDATA LTD.	HuMANDATA	出カファイル名
TITLE: ACM-201		ACM201C .G3
PART NO.: ACM-201C	Design: S.ushiro	
FILE NAME: ACM201C.Pcb	DATE: 4-Oct-2005	2005/10/04

有限会社ヒューマンデータ

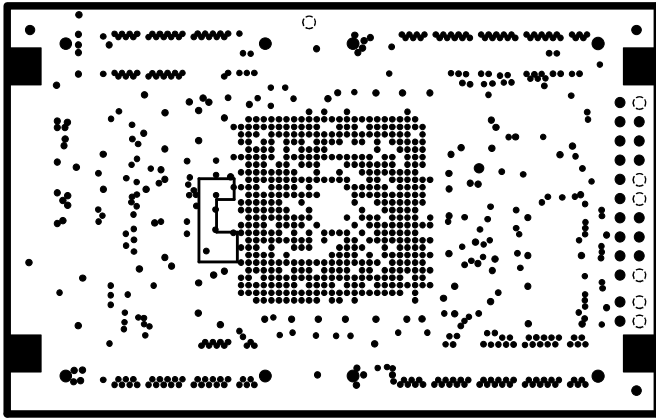

L1 : Signal Top		0.5oz
L2 : Signal mid1		0.5oz
L3 : Signal mid2		0.5oz
L4 : Signal mid3		0.5oz
L5 : GND	InternalPlane1	1oz
L6 : V33_A		1oz
L7 : Signal mid4		0.5oz
L8 : Signal mid5		0.5oz
L9 : Signal mid6		0.5oz
L10 : Signal Bottom		0.5oz

HuMANDATA LTD.	HuMANDATA	出カファイル名
TITLE: ACM-201		ACM201C .GP1
PART NO.: ACM-201C	Design: S.ushiro	
FILE NAME: ACM201C.Pcb	DATE: 4-Oct-2005	2005/10/04

有限会社ヒューマンデータ

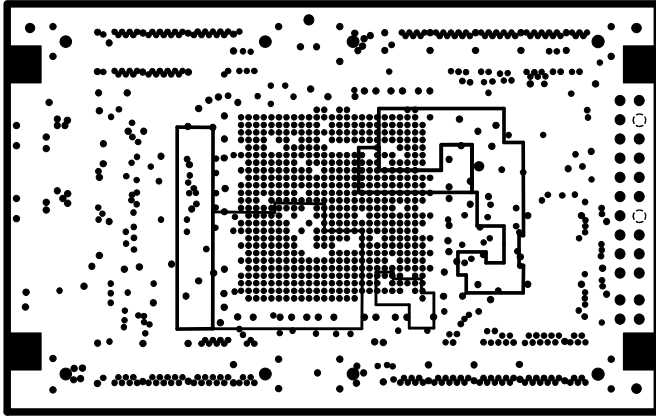

L1 : Signal Top		0.5oz
L2 : Signal mid1		0.5oz
L3 : Signal mid2		0.5oz
L4 : Signal mid3		0.5oz
L5 : GND		1oz
L6 : V33_A	InternalPlane2	1oz
L7 : Signal mid4		0.5oz
L8 : Signal mid5		0.5oz
L9 : Signal mid6		0.5oz
L10 : Signal Bottom		0.5oz

HuMANDATA LTD.	HuMANDATA	出カファイル名
TITLE: ACM-201		ACM201C .GP2
PART NO.: ACM-201C	Design: S.ushiro	
FILE NAME: ACM201C.Pcb	DATE: 4-Oct-2005	2005/10/04

有限会社ヒューマンデータ

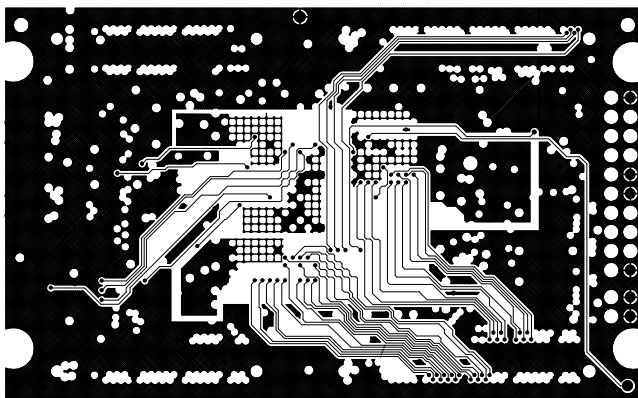

L1 : Signal Top		0.5oz
L2 : Signal mid1		0.5oz
L3 : Signal mid2		0.5oz
L4 : Signal mid3		0.5oz
L5 : GND		1oz
L6 : U33_A		1oz
L7 : Signal mid4	MidLayer 4	0.5oz
L8 : Signal mid5		0.5oz
L9 : Signal mid6		0.5oz
L10 : Signal Bottom		0.5oz

HuMANDATA LTD.	HuMANDATA	出カファイル名
TITLE: ACM-201		ACM201C .G4
PART NO.: ACM-201C	Design: S.ushiro	
FILE NAME: ACM201C.Pcb	DATE: 4-Oct-2005	2005/10/04

有限会社ヒューマンデータ

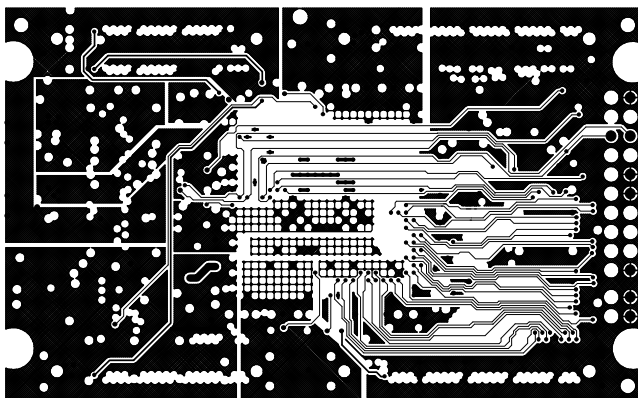

L1 : Signal Top		0.5oz
L2 : Signal mid1		0.5oz
L3 : Signal mid2		0.5oz
L4 : Signal mid3		0.5oz
L5 : GND		1oz
L6 : U33_A		1oz
L7 : Signal mid4		0.5oz
L8 : Signal mid5	MidLayer5	0.5oz
L9 : Signal mid6		0.5oz
L10 : Signal Bottom		0.5oz

HuMANDATA LTD.	HuMANDATA	出カファイル名
TITLE: ACM-201		ACM201C .G5
PART NO.: ACM-201C	Design: S.ushiro	
FILE NAME: ACM201C.Pcb	DATE: 4-Oct-2005	2005/10/04

有限会社ヒューマンデータ

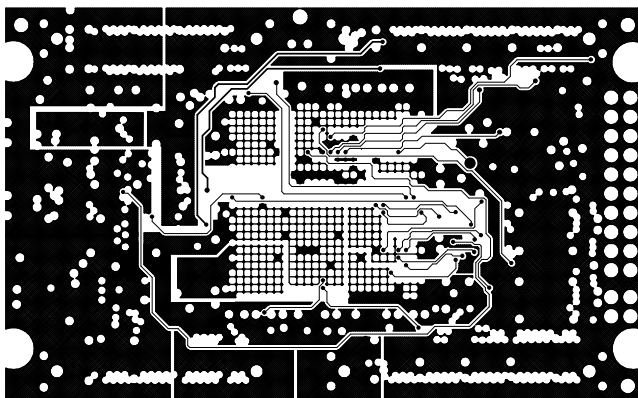

L1 : Signal Top		0.5oz
L2 : Signal mid1		0.5oz
L3 : Signal mid2		0.5oz
L4 : Signal mid3		0.5oz
L5 : GND		1oz
L6 : U33_A		1oz
L7 : Signal mid4		0.5oz
L8 : Signal mid5		0.5oz
L9 : Signal mid6	MidLayer 6	0.5oz
L10 : Signal Bottom		0.5oz

HuMANDATA LTD.	HuMANDATA	出カファイル名
TITLE: ACM-201		ACM201C .G6
PART NO.: ACM-201C	Design: S.ushiro	
FILE NAME: ACM201C.Pcb	DATE: 4-Oct-2005	2005/10/04

有限会社ヒューマンデータ

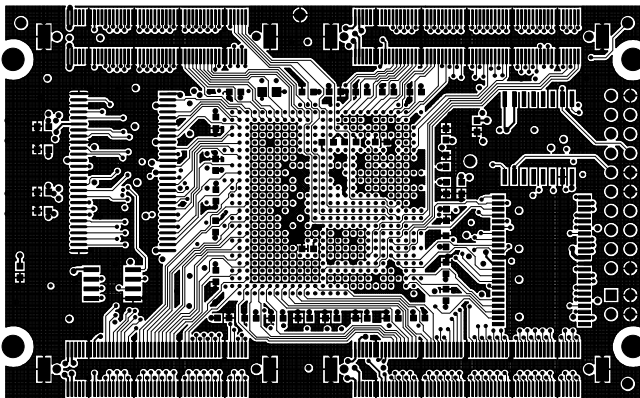

L1 : Signal Top		0.5oz
L2 : Signal mid1		0.5oz
L3 : Signal mid2		0.5oz
L4 : Signal mid3		0.5oz
L5 : GND		1oz
L6 : V33_A		1oz
L7 : Signal mid4		0.5oz
L8 : Signal mid5		0.5oz
L9 : Signal mid6		0.5oz
L10 : Signal Bottom	BottomLayer	0.5oz

HuMANDATA LTD.	HuMANDATA	出カファイル名
TITLE: ACM-201		ACM201C .GBL
PART NO.: ACM-201C	Design: S.ushiro	
FILE NAME: ACM201C.Pcb	DATE: 4-Oct-2005	2005/10/04

有限会社ヒューマンデータ

2005/10/04

HUMANDATA

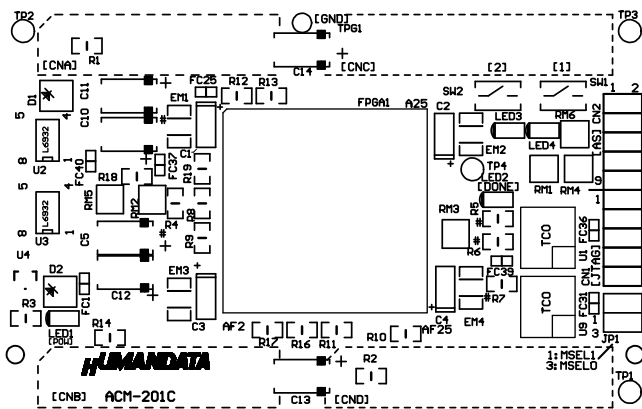

HuMANDATA LTD.

ACM-201C

Top Overlay

L1 : Signal Top	0.5oz
L2 : Signal mid1	0.5oz
L3 : Signal mid2	0.5oz
L4 : Signal mid3	0.5oz
L5 : GND	1oz
L6 : V33_A	1oz
L7 : Signal mid4	0.5oz
L8 : Signal mid5	0.5oz
L9 : Signal mid6	0.5oz
L10 : Signal Bottom	0.5oz

HuMANDATA LTD.	HUMANDATA	出カファイル名
TITLE: ACM-201		ACM201C .GTO
PART NO.: ACM-201C	Design: S.ushiro	
FILE NAME: ACM201C.Pcb	DATE: 4-Oct-2005	2005/10/04

有限会社ヒューマンデータ

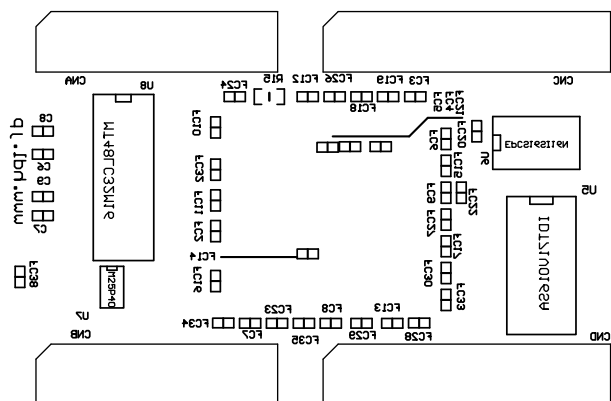

L1 : Signal Top	0.5oz
L2 : Signal mid1	0.5oz
L3 : Signal mid2	0.5oz
L4 : Signal mid3	0.5oz
L5 : GND	1oz
L6 : V33_A	1oz
L7 : Signal mid4	0.5oz
L8 : Signal mid5	0.5oz
L9 : Signal mid6	0.5oz
L10 : Signal Bottom	0.5oz

Bottom Overlay

HuMANDATA LTD.	HuMANDATA	出カファイル名
TITLE: ACM-201		ACM201C .GBO
PART NO.: ACM-201C	Design: S.ushiro	
FILE NAME: ACM201C.Pcb	DATE: 4-Oct-2005	2005/10/04

有限会社ヒューマンデータ