

IOA[0..49]	IOA[0..49]
CLKA	CLKA
XNCONFIG	XNCONFIG
CLK_EXAP	CLK_EXAP
CLK_EXAN	CLK_EXAN
SDADD[0..12]	SDADD[0..12]
SDADD[13]	SDADD[13]
SDADD[14]	SDADD[14]
MRAM_A[1..18]	MRAM_A[1..18]
MRAM_DQ[0..7]	MRAM_DQ[0..7]
MRAM_DQ[8..15]	MRAM_DQ[8..15]
MRAM_WE	MRAM_WE

IOB[0..49]	IOB[0..49]
CLK_EXBP	CLK_EXBP
CLK_EXBN	CLK_EXBN
SDADD[0..12]	SDADD[0..12]
SDADD[13]	SDADD[13]
SDADD[14]	SDADD[14]
MRAM_A[1..18]	MRAM_A[1..18]
MRAM_DQ[0..7]	MRAM_DQ[0..7]
MRAM_DQ[8..15]	MRAM_DQ[8..15]
MRAM_WE	MRAM_WE

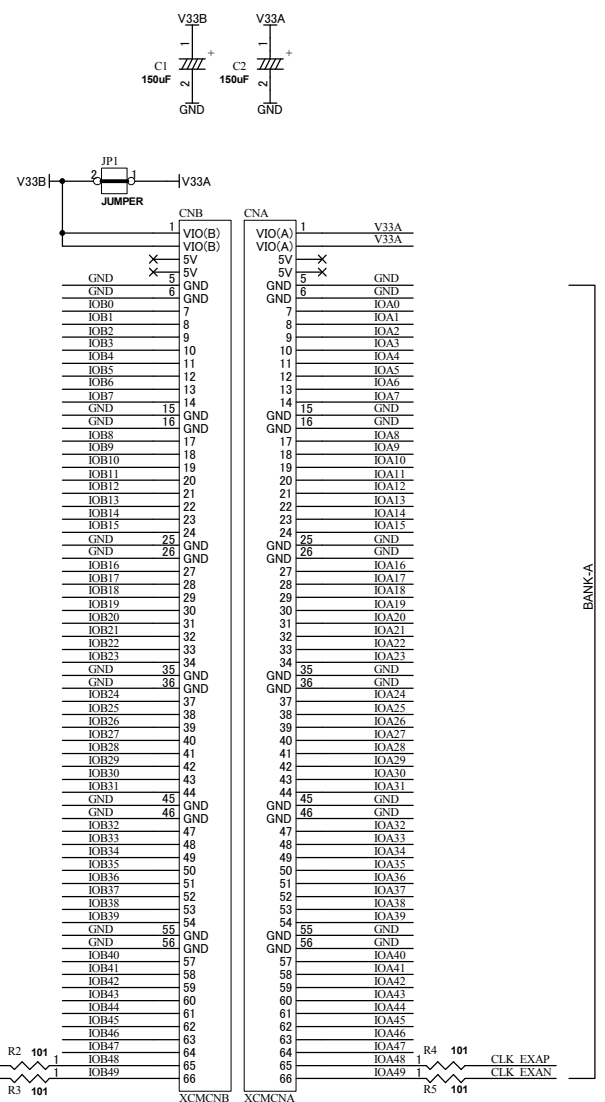
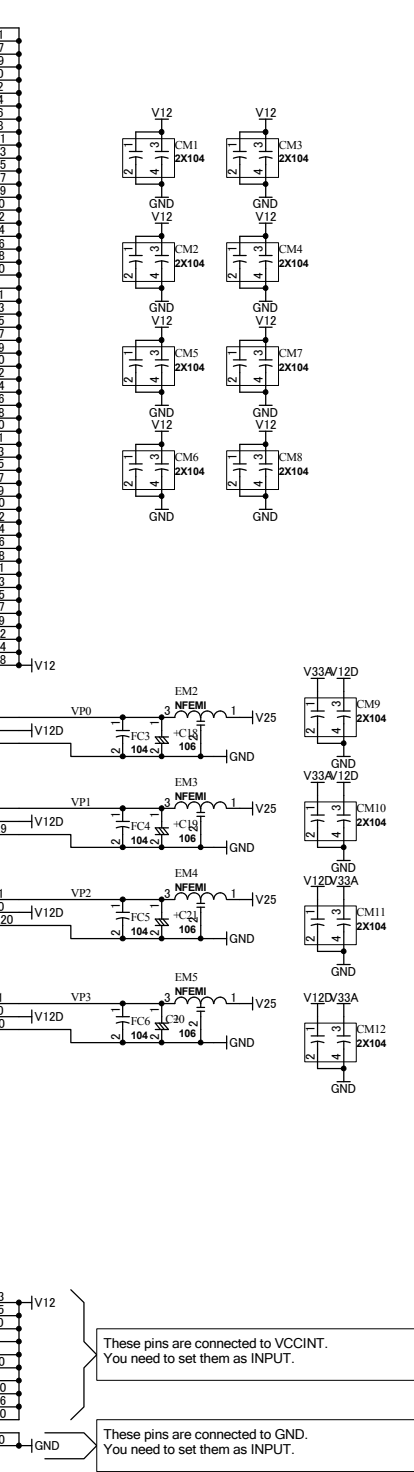
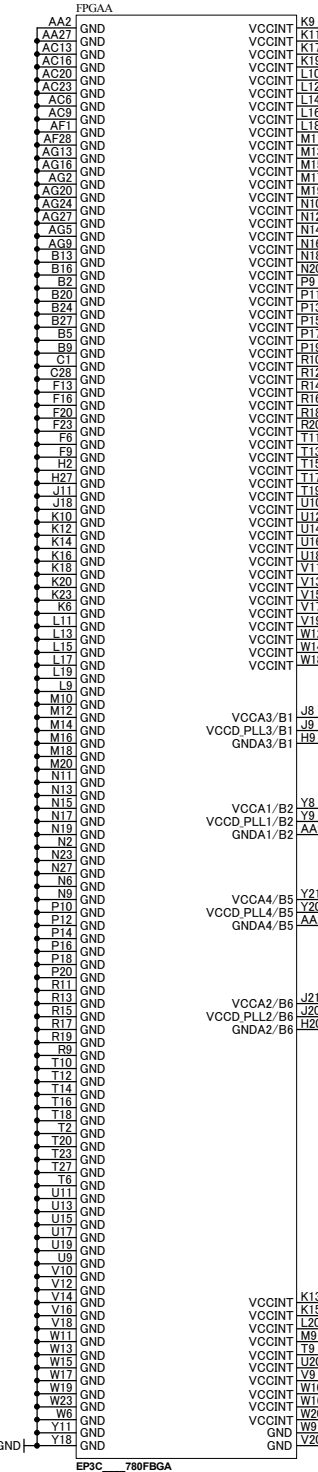

ACM022A1.sch.pdf

	HuMANDATA LTD. OSAKA JAPAN www.hdl.co.jp/en/ (Global) www.hdl.co.jp/ (Japan)		Altera CycloneIII F780 FPGA board	
	Date: 13-Nov-2009 15:27:38	DOC. No. ACM-022	File: ACM022A.sch	Sheet 1 of 3

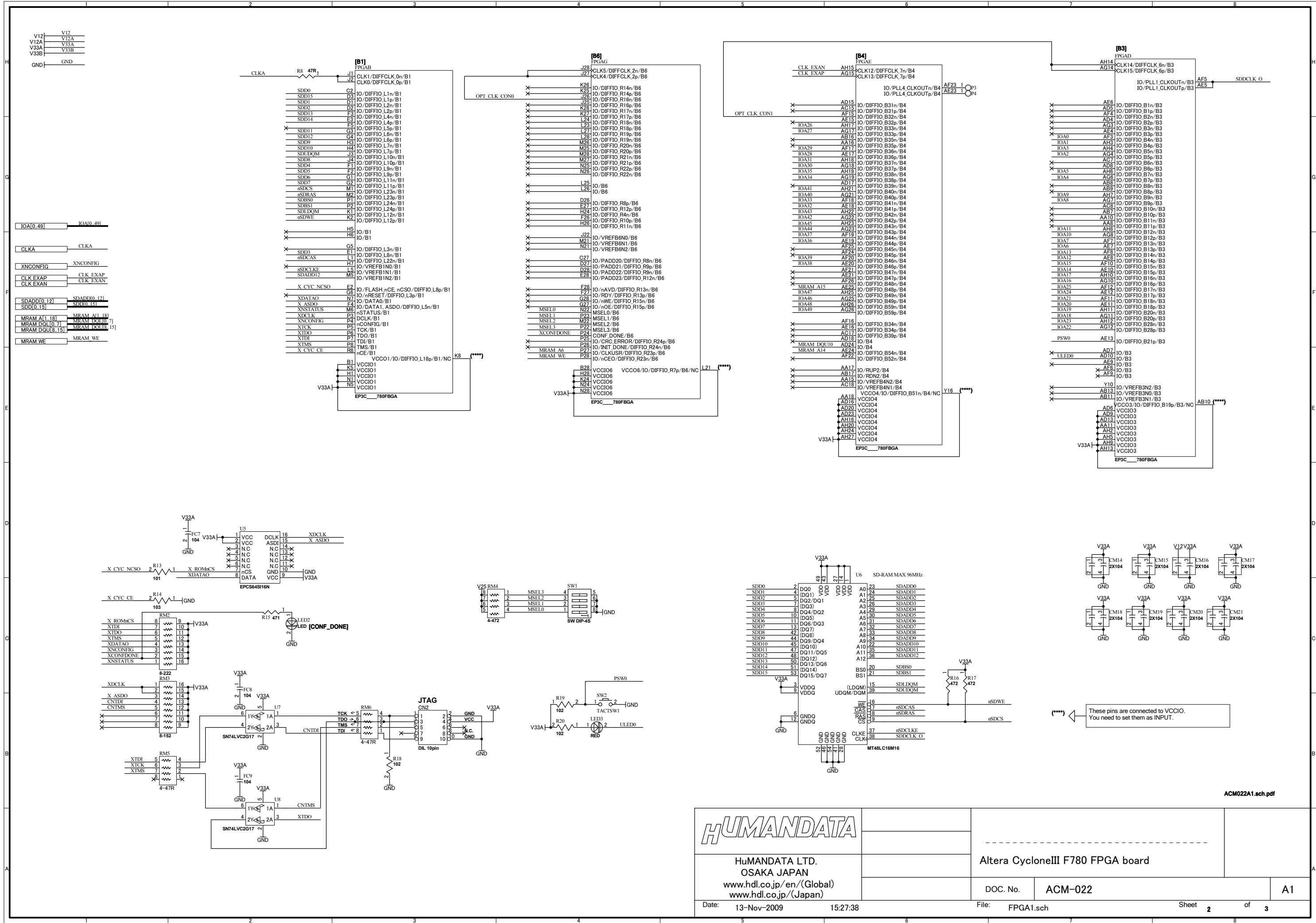



HuMANDATA LTD.
OSAKA JAPAN
www.hdl.co.jp/en/(Global)
www.hdl.co.jp/(Japan)

Altera CycloneIII F780 FPGA board

Date:	13-Nov-2009	15:27:38	File:	FPGA1.sch	Sheet 2 of 3
DOC. No.	ACM-022		A1		

ACM022A1.sch.pdf

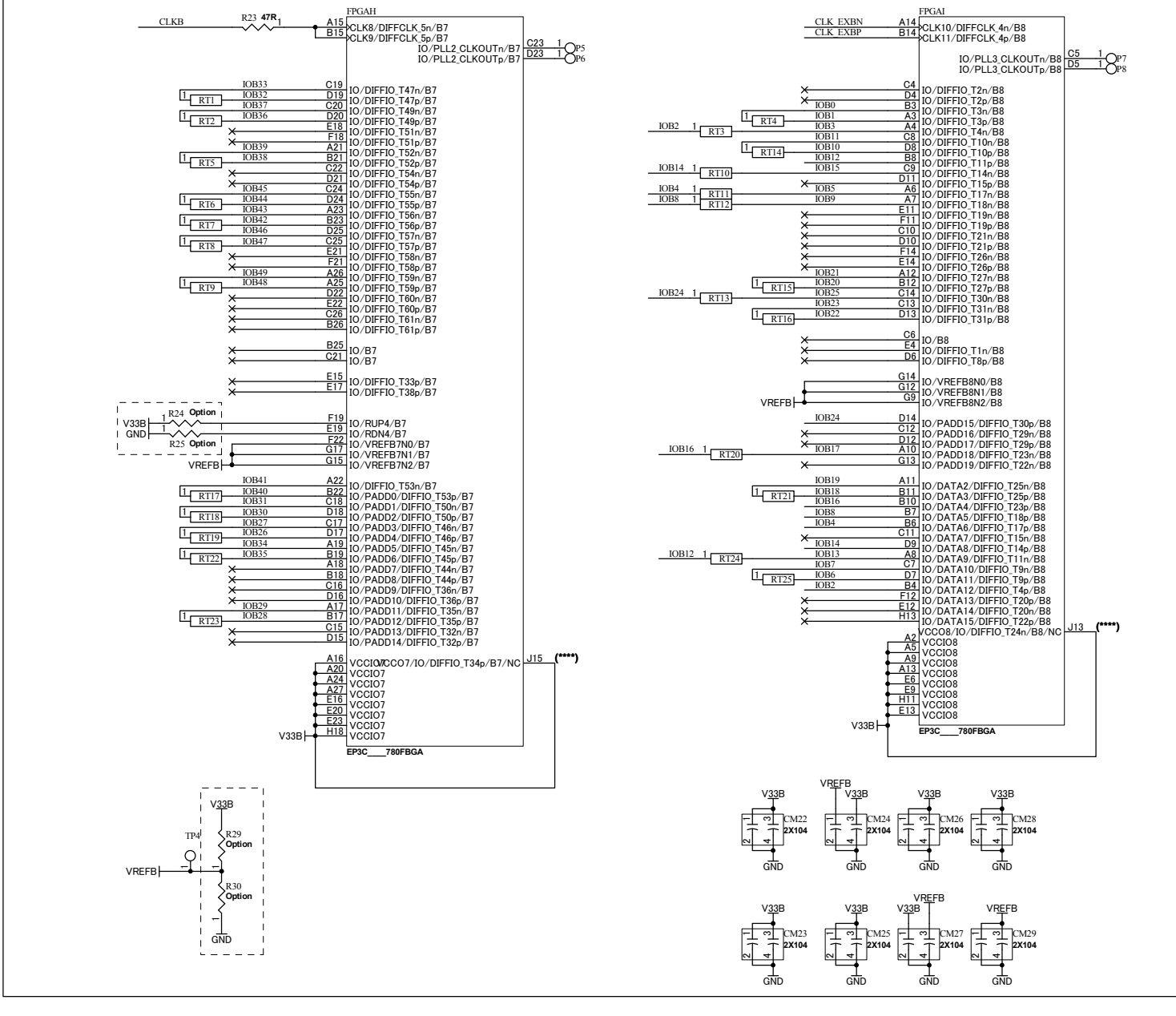
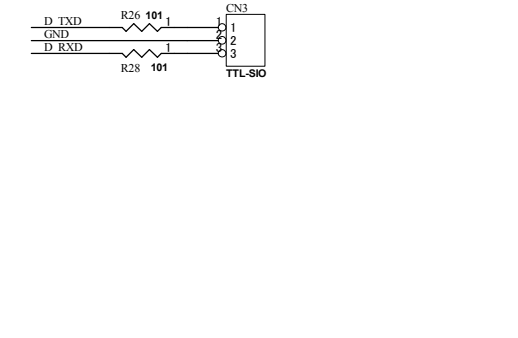
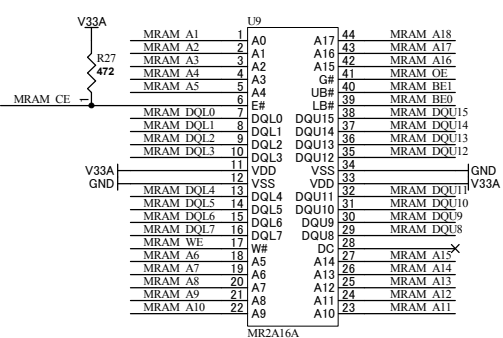
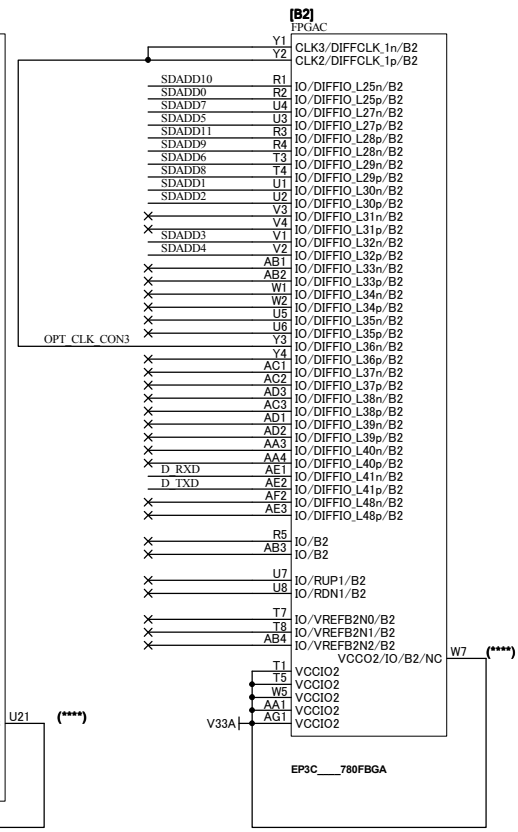
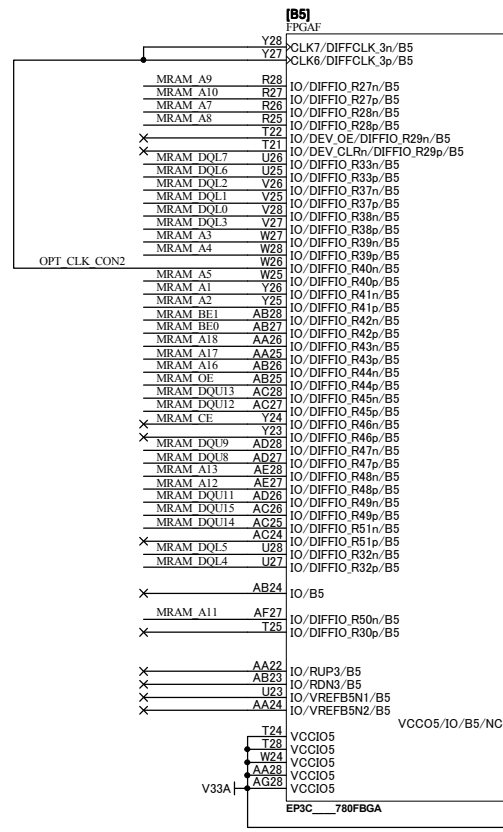
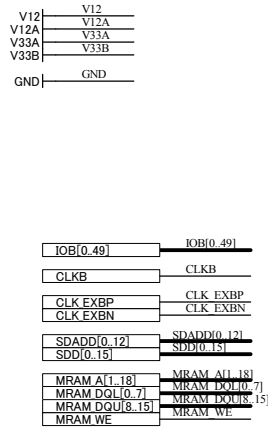

(****) These pins are connected to VCCIO. You need to set them as INPUT.

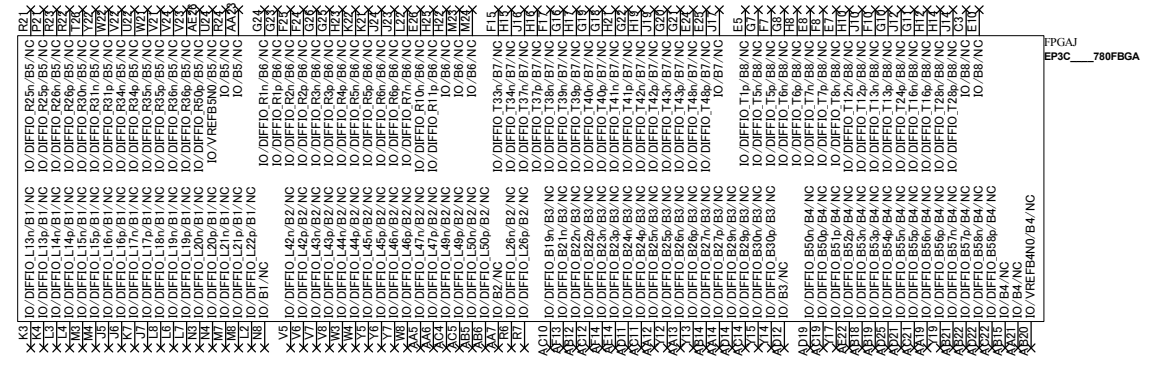

HUMANDATA LTD.
OSAKA JAPAN
www.hdl.co.jp/en/ (Global)
www.hdl.co.jp/ (Japan)

Altera CycloneIII F780 FPGA board

DOC. No.	ACM-022	A1
Date:	13-Nov-2009 15:27:38	
File:	FPGA2.sch	Sheet 3 of 3

ACM022A1.sch.pdf