

HuMANDATA LTD.  
OSAKA JAPAN  
www.hdl.co.jp/en/(Global)  
www.hdl.co.jp/(Japan)

2011/02/24  
Date: 24-Feb-2011 09:50:27

Cyclone3 Bread Board( F484 )  
DOC. No. ACM-021  
File: ACM021A.sch  
Sheet 1 of 3



V12 V12A  
V124 V12B  
V33A V33B

GND GND

IOB(0..49) IOB0..49I

CLKB CLKB

CLK2 CLK2

CLK3 CLK3

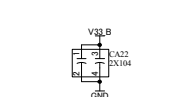
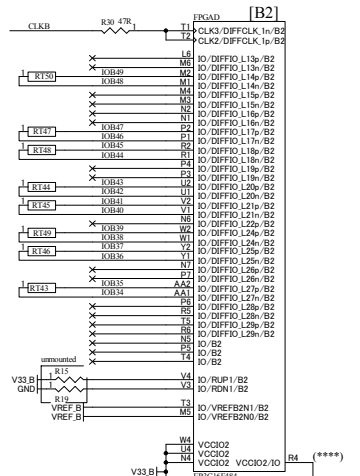
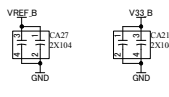
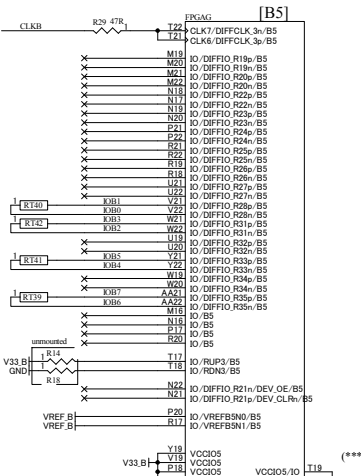
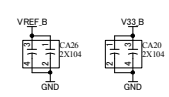
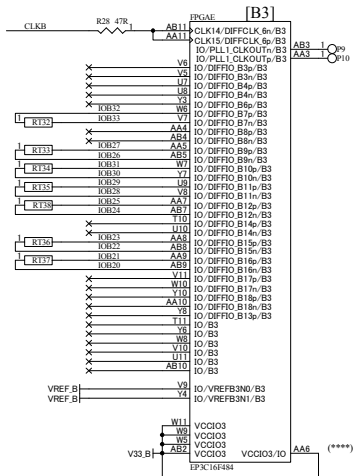
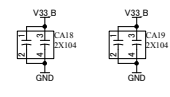
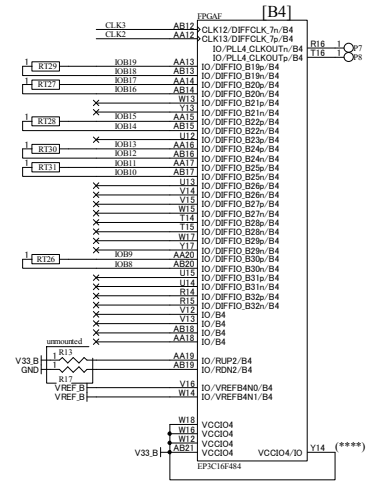

\*\*\*\* These pins are connected to GND or VCCINT. You need to set them as INPUT.

ACM021R1-SCH-A2.pdf

	2011/02/24			
	HuMANDATA LTD. OSAKA JAPAN <a href="http://www.hdl.co.jp/en/">www.hdl.co.jp/en/</a> (Global) <a href="http://www.hdl.co.jp/">www.hdl.co.jp/</a> (Japan)	Cyclone3 Bread Board( F484 )		
Date:	24-Feb-2011	DOC. No.	ACM-021	A2
	09:50:28	File:	FPGA2.sch	Sheet 3 of 3