

WIRING STRUCTURE :

P1	SIGNAL NAME	AWG	COLOR	P1
1	VCC	24	RED	1
2	D-	28	WHITE	2
3	D+	28	GREEN	3
4	GND	24	BLACK	4
5	SHIELD WIRE			5

型番	L寸法
P112-S	305mm
P112-M	610mm

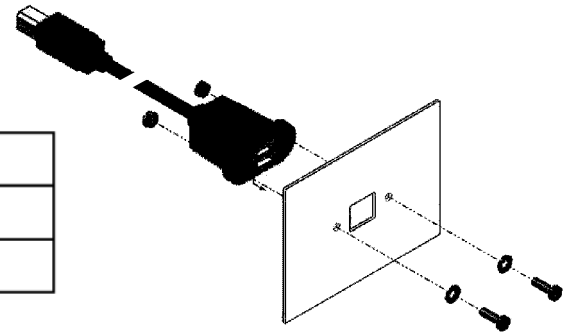

(寸法は公称値です)

ケーブル : USB SHIELDED HIGH SPEED CABLE 2.0 28AWG/1P + 24AWG/2C
 MOULDING MATERIAL : PVC BLACK

パネルカット寸法例

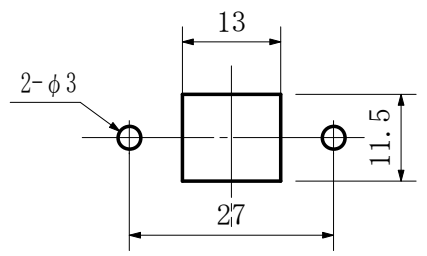

HUMANDATA		UNIT mm	TITLE P112シリーズ Outline Drawing	
CHK	DWG	SCALE 1/1	DWG NO P112-DWG-E	REV E

