

REVISION AY

PATENT NUMBER
7172438

DO NOT
SCALE FROM
THIS PRINT

FIG. 1 SEAM-10-07.0-S-04-2-A-K-TR SEAM-XX-XX.X-XX-XX-X-A-XX-K-TR
 -08: 8 ROW
 (SEAM-30-02.0-XX-08-1-A-XX-K-TR SHOWN)
 (SOME CENTER FEATURES, INCLUDING -K, NOT SHOWN FOR CLARITY)

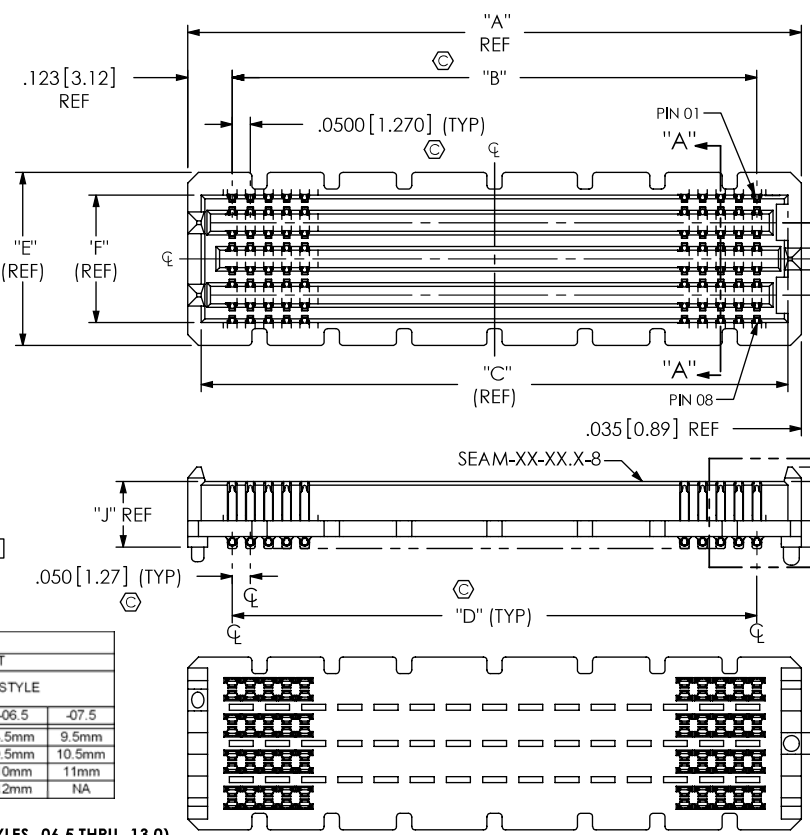

- No OF POSITIONS**
 -10,*-15****-19-20,
 *****-25,-30,-40,-50
 (PER ROW)
- LEAD STYLE**
 -02.0 (SEE TABLE 1 & 2)
 -03.0 (SEE TABLE 1 & 2)
 -03.5 (SEE TABLE 1 & 2)
 *-05.5 (SEE TABLE 1 & 2)
 ☒ -06.5 (SEE TABLE 9 & 10)
 -07.0 (SEE TABLE 9 & 10)
 -09.0 (SEE TABLE 9 & 10)
 -11.0 (SEE TABLE 9 & 10)
 * -13.0 (SEE TABLE 9 & 10)

- PLATING SPECIFICATION**
 -L: LIGHT GOLD IN CONTACT AREA, MATTE TIN ON TAIL
 -(LEAD STYLE -02.0 THRU-03.5: USE SUB-T-1M36-XX-X-L-X)
 -(LEAD STYLE -06.5 THRU-13.0: USE SUB-T-1M38-XX-X-L-X)
 -SM: SELECTIVE GOLD IN CONTACT AREA, MATTE TIN ON TAIL
 -(LEAD STYLE -02.0 THRU-03.5: USE SUB-T-1M36-XX-X-S-X)
 -(LEAD STYLE -06.5 THRU-13.0: USE SUB-T-1M38-XX-X-S-X)
- S: SELECTIVE GOLD IN CONTACT AREA, MATTE TIN ON TAIL**
 -(LEAD STYLE -02.0 THRU-03.5: USE SUB-T-1M36-XX-X-S-X)
 -(LEAD STYLE -06.5 THRU-13.0: USE SUB-T-1M38-XX-X-S-X)
- ROW**
 -04: 4 ROWS (SEE FIG 13, SHT 6)
 (NOT AVAILABLE IN -13.0 LEAD STYLE)
 -05: 5 ROWS (SEE FIG. 7, SHT 4)
 -06: 6 ROWS (SEE FIG. 6, SHT 4)
 -08: 8 ROWS (SEE FIG. 1)
 -10: 10 ROWS (SEE FIG. 2, SHT 2)

- TAPE & REEL**
 (SEE NOTES 9, 10 & 11)
- POLYIMIDE PAD**
 (SEE FIG. 4, SHT 2)
 (SEE NOTE 8)
- DOT APPLICATOR-KAPTON TAPE**
 -04 ROW: USE K-DOT-138-250-005
 -05/-06 ROW: USE K-DOT-236-343-005
 -08 ROW: USE K-DOT-325-450-005
 -10 ROW: USE K-DOT-404-500-005
- OPTION**
 -GP: GUIDE POST (SEE FIG. 8, SHT 5)
 (ONLY AVAILABLE WITH -02.0 LEAD STYLE, 20, 30, 40, & 50 POSITION)
 -EP: EXTENDED GUIDE POST (SEE FIG. 10, SHT 5)
 (ONLY AVAILABLE WITH -02.0 & -03.5 LEAD STYLE, 20, 30, 40, & 50 POSITION)
- ALIGNMENT PIN**
 (SEE FIG. 3, SHT 2)
 (SEE NOTE 7)
 (SEE NOTE 14)
- SOLDER COMPOSITION & STYLE**
 -1: 63% TIN / 37% LEAD
CHARGE TAIL
 (USE SUB-T-1M3X-XX-X-X-1)
 -2: 95.5% TIN / 3.8% SILVER / .7% COPPER **CHARGE TAIL**
 (USE SUB-T-1M3X-XX-X-X-2)
 -3: 63% TIN / 37% LEAD
CRIMP TAIL
 (USE SUB-T-1M85-XX-X-X-1)
 (SEE FIG. 12, SHT 8)
 (ONLY AVAILABLE ON -02.0, -03.0 & -03.5 LEAD STYLES)
 -4: 95.5% TIN / 3.8% SILVER / .7% COPPER **CRIMP TAIL**
 (USE SUB-T-1M85-XX-X-X-2)
 (SEE FIG. 12, SHT 8)
 (ONLY AVAILABLE ON -02.0, -03.0 & -03.5 LEAD STYLES)

TABLE 12

LEAD STYLE	"AA"
-02.0	0.270 [0.686]
-03.0	0.690 [1.676]
-03.5	0.890 [2.184]
-05.5	1.640 [4.166]
-06.5	0.430 [1.092]
-07.0	0.430 [1.092]
-09.0	0.430 [1.092]
-11.0	0.430 [1.092]

TABLE 2
STACK HEIGHT

SEAM LEAD STYLE	-05.0	-06.0	-06.5	-07.5
-02.0	7mm	8mm	8.5mm	9.5mm
-03.0	8mm	9mm	9.5mm	10.5mm
-03.5	8.5mm	9.5mm	10mm	11mm
-05.5	NA	NA	12mm	NA

* = NOT TOOLED
 (SEE SHEET 3 FOR LEAD STYLES -06.5 THRU -13.0)

TABLE 1

STYLE	"J"	BODY CALLOUT	TERMINAL
-02.0	0.181 [4.60]	SEAM-XX-02.0-XX-X	SUB-T-1M36-02.0-X-X
-03.0	0.220 [5.59]	SEAM-XX-03.0-XX-X	SUB-T-1M36-03.0-X-X
-03.5	0.240 [6.10]	SEAM-XX-03.5-XX-X	SUB-T-1M36-03.5-X-X
-05.5	0.319 [8.10]	SEAM-XX-05.5-XX-X	SUB-T-1M36-05.5-X-X

TABLE 13

LEAD STYLE	"U"		
	10-30 POS.	40 POS.	50 POS.
-02.0, -03.0			
-03.5, -05.5, -06.5, -07.0, -09.0, *-13.0	.006 [0.152]	.009 [0.229]	.009 [0.229]
-11.0	.0085 [0.216]	.009 [0.229]	.009 [0.229]

TABLE 4

No. OF ROWS	"E"	"F"	"G"	"H"
-04	.278 [7.06]	.152 [3.86]	.100 [2.54]	.050 [1.27]
-05, -06	.378 [9.60]	.252 [6.40]	.100 [2.54]	.050 [1.27]
-08	.478 [12.14]	.352 [8.94]	.200 [5.08]	.100 [2.54]
-10	.578 [14.68]	.452 [11.48]	.300 [7.62]	.150 [3.81]

TABLE 3

No. OF POS	"A"	"B"	"C"	"D"
***-10	.696 [17.68]	.450 [11.43]	.622 [15.80]	.450 [11.43]
****-15	.946 [24.03]	.700 [17.78]	.872 [22.15]	.700 [17.78]
****-19	1.146 [29.11]	.900 [22.86]	1.072 [27.23]	.900 [22.86]
-20	1.196 [30.38]	.950 [24.13]	1.122 [28.50]	.950 [24.13]
*****-25	1.446 [36.73]	1.200 [30.48]	1.372 [34.85]	1.200 [30.48]
-30	1.696 [43.08]	1.450 [36.83]	1.622 [41.20]	1.450 [36.83]
-40	2.196 [55.78]	1.950 [49.53]	2.122 [53.90]	1.950 [49.53]
-50	2.696 [68.48]	2.450 [62.23]	2.622 [66.60]	2.450 [62.23]

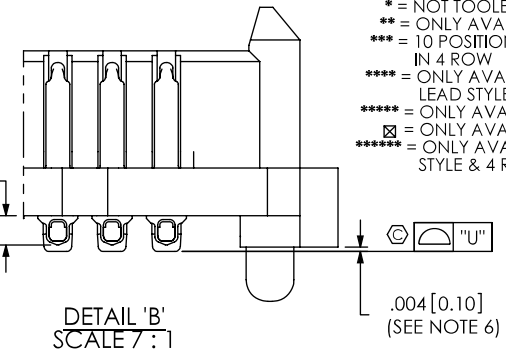

- * = NOT TOOLED
- ** = ONLY AVAILABLE WITH 19 POSITION, 6 ROWS
- *** = 10 POSITION ONLY AVAILABLE IN 4 ROW
- **** = ONLY AVAILABLE IN 6 ROW WITH -03.5 OR -05.5 LEAD STYLE
- ***** = ONLY AVAILABLE IN A 10 ROW
- ☒ = ONLY AVAILABLE IN 8 & 10 ROW
- ***** = ONLY AVAILABLE WITH -02.0 OR -03.5 LEAD STYLE & 4 ROW

- NOTES:
- ⊙ REPRESENTS A CRITICAL DIMENSION.
 - MINIMUM PUSHOUT FORCE: 0.75 LBS.
 - NOTE DELETED.
 - 5 ROW SOLDER TAILS ARE NOT SYMMETRICAL WITH BODY WIDTH (.378 [9.60]); SEE FIG. 7, SHEET 4.
 - C18 TO BE INSPECTED OPTICALLY WHILE FOCUSED ON THIS SURFACE.
 - DIMENSION TO BE MEASURED IN ALL FOUR CORNERS.
 - WITHOUT -A AVAILABLE FOR EXISTING CUSTOMERS ONLY AS OF REVISION AD.
 - POLYIMIDE PAD WILL BE SUPPLIED WHETHER OR NOT -K IS SPECIFIED.
 - TAPE & REEL WILL BE SUPPLIED WHETHER OR NOT -TR IS SPECIFIED.
 - FOR QUANTITIES UP TO 49 PIECES, NO LEADER, TRAILER, OR REEL WILL BE SUPPLIED. FOR QUANTITIES 50 - 124, NO LEADER OR TRAILER WILL BE SUPPLIED.
 - ATTACH LABEL "SEAX-0001" TO EACH TAPE & REEL PACKAGE.
 - SEE RECOMMENDED FOOTPRINT DRAWING FOR STENCIL REQUIREMENTS.
 - SOLDER CHARGE VOLUME IS 0.891 x 10^-5 IN ^3 REF.
 - FOR VITA REQUIREMENTS, -A PIN SHOULD NOT BE ORDERED.

UNLESS OTHERWISE SPECIFIED, DIMENSIONS ARE IN INCHES.

TOLERANCES ARE:
 DECIMALS .XX: ±.01 [3]
 .XXX: ±.005 [13]
 .XXXX: ±.0020 [051]

ANGLES 2°

PROPRIETARY NOTE
 THIS DOCUMENT CONTAINS INFORMATION CONFIDENTIAL AND PROPRIETARY TO SAMTEC, INC. AND SHALL NOT BE REPRODUCED OR TRANSFERRED TO OTHER DOCUMENTS OR DISCLOSED TO OTHERS OR USED FOR ANY PURPOSE OTHER THAN THAT WHICH IT WAS OBTAINED WITHOUT THE EXPRESSED WRITTEN CONSENT OF SAMTEC, INC.

MATERIAL: DO NOT SCALE DRAWING
 INSULATOR: LCP, COLOR: BLACK
 TERMINAL: COPPER ALLOY

SHEET SCALE: 2:1

samtec

520 PARK EAST BLVD, NEW ALBANY, IN 47150
 PHONE: 812-944-6733 FAX: 812-948-5047
 e-Mail info@SAMTEC.com code 55322

DESCRIPTION:
 .050 PITCH TERMINAL ARRAY ASSEMBLY
 DWG. NO.
SEAM-XX-XX.X-XX-XX-X-A-XX-K-TR
 BY: BRATCHER 08-09-2010 SHEET 1 OF 8

REVISION AY

FIG. 2
 -10: 10 ROW
 (SAME AS FIG. 1, EXCEPT AS SHOWN)
 (SEAM-30-02.0-XX-10-1-A-XX-K-TR SHOWN)
 (SOME CENTER FEATURES, INCLUDING -K, NOT SHOWN FOR CLARITY)

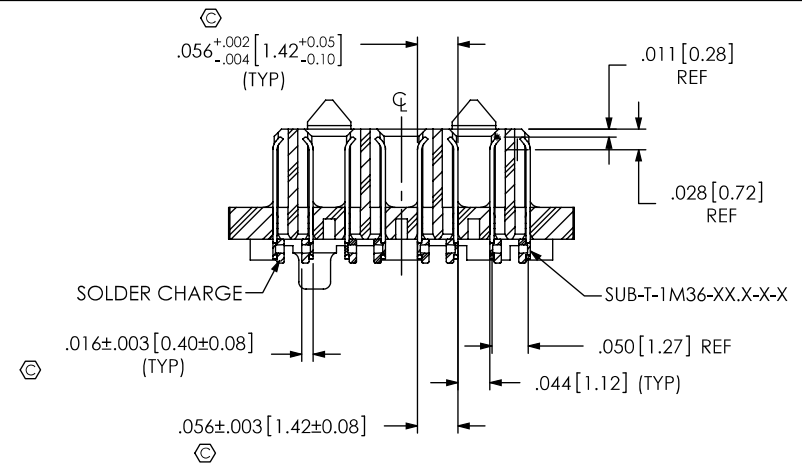
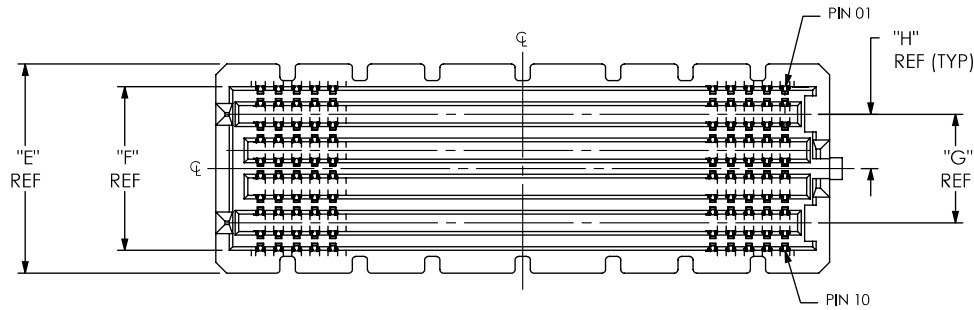
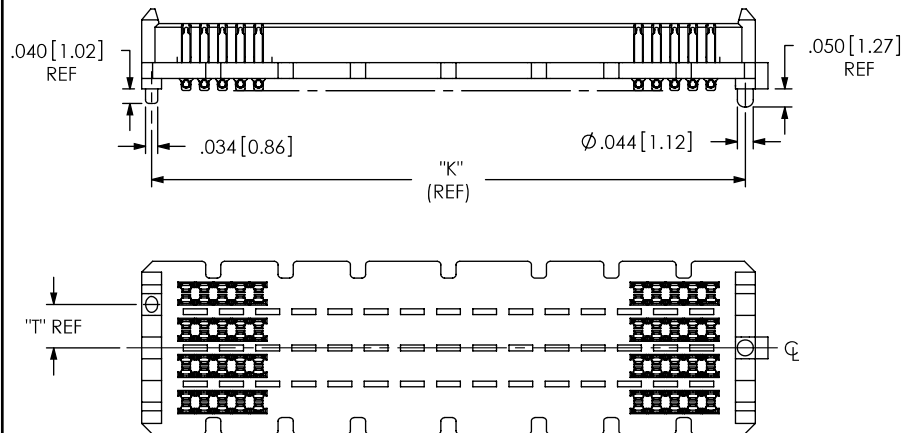

FIG. 3
 -A: ALIGNMENT PINS
 APPLIES TO ALL -A OPTION PART NUMBERS
 (SAME AS FIG. 1, EXCEPT AS SHOWN)
 (SEAM-30-02.0-XX-08-1-A-XX-K-TR SHOWN)
 (SOME CONTACTS NOT SHOWN FOR CLARITY)



No. OF ROWS	"T"
-04	.079[2.01]
-05	.120[3.05]
-06	.120[3.05]
-08	.120[3.05]
-10	.120[3.05]

No. OF POS	"K"
***-10	.641[16.28]
*****-15	.891[22.63]
-20	1.141 [28.98]
*****-25	1.391[35.33]
-30	1.641 [41.68]
-40	2.141 [54.38]
-50	2.641 [67.08]

*** = 10 POSITION ONLY AVAILABLE IN 4 ROW
 ***** = ONLY AVAILABLE IN A 10 ROW
 ***** = ONLY AVAILABLE WITH -02.0 OR -03.5 LEAD STYLE AND A 4 ROW.

FIG. 4
 -K: POLYIMIDE PAD
 (SEAM-30-02.0-XX-08-1-A-XX-K-TR SHOWN)
 (SAME AS FIG. 1, EXCEPT AS SHOWN)
 (ALL CONTACTS NOT SHOWN FOR CLARITY)

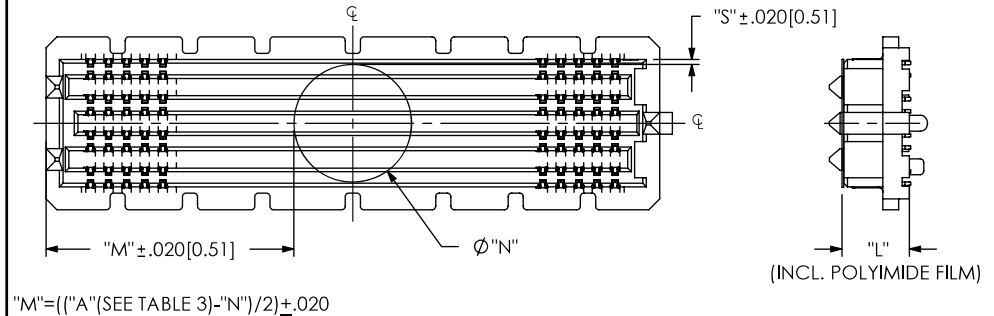

LEAD STYLE	"L"
-02.0	.186 [4.72]
-03.0	.225 [5.72]
-03.5	.245 [6.22]
-06.5	.365 [9.27]
-07.0	.382 [9.70]
-09.0	.461 [11.71]
-11.0	.540 [13.72]
*-13.0	.619 [15.72]

* = NOT TOOLED

No. OF ROWS	ϕ "N"	"S"
-04	.138[3.50]	.007[.18]
-05, -06	.236 [6.00]	.008 [0.20]
-08	.325 [8.25]	.014 [0.34]
-10	.404 [10.25]	.024 [0.61]

PROPRIETARY NOTE
 THE DOCUMENT CONTAINS INFORMATION CONFIDENTIAL AND PROPRIETARY TO SAMTEC, INC. AND SHALL NOT BE REPRODUCED OR TRANSFERRED TO OTHER DOCUMENTS OR DISCLOSED TO OTHERS OR USED FOR ANY PURPOSE OTHER THAN THAT WHICH IT WAS OBTAINED WITHOUT THE EXPRESSED WRITTEN CONSENT OF SAMTEC, INC.

DO NOT SCALE DRAWING

SHEET SCALE: 2:1

samtec

520 PARK EAST BLVD, NEW ALBANY, IN 47150
 PHONE: 812-944-6733 FAX: 812-948-5047
 e-Mail info@SAMTEC.com code 55322

DESCRIPTION:
 .050 PITCH TERMINAL ARRAY ASSEMBLY
 DWG. NO.
 SEAM-XX-XX.X-XX-XX-X-A-XX-K-TR

REVISION AY

FIG. 5

-06.5 THRU -13.0 LEAD STYLES
(SAME AS FIG. 1, EXCEPT AS SHOWN)
(SEAM-30-09.0-XX-08-X-A-XX-K-TR SHOWN)
(SOME CENTER FEATURES, INCLUDING -K, NOT SHOWN FOR CLARITY)

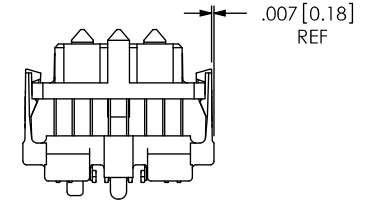
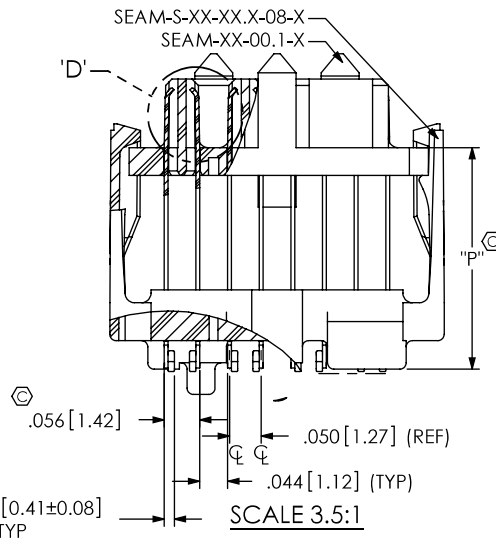
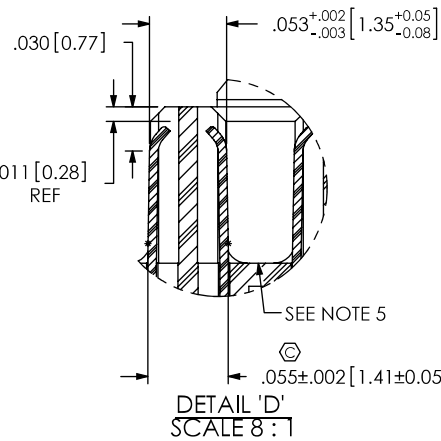
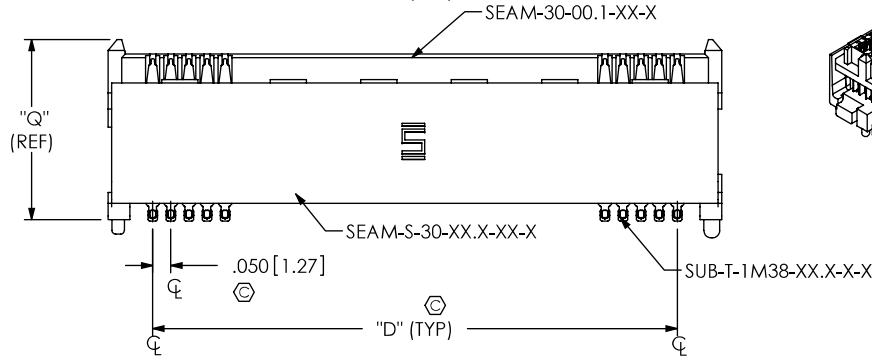
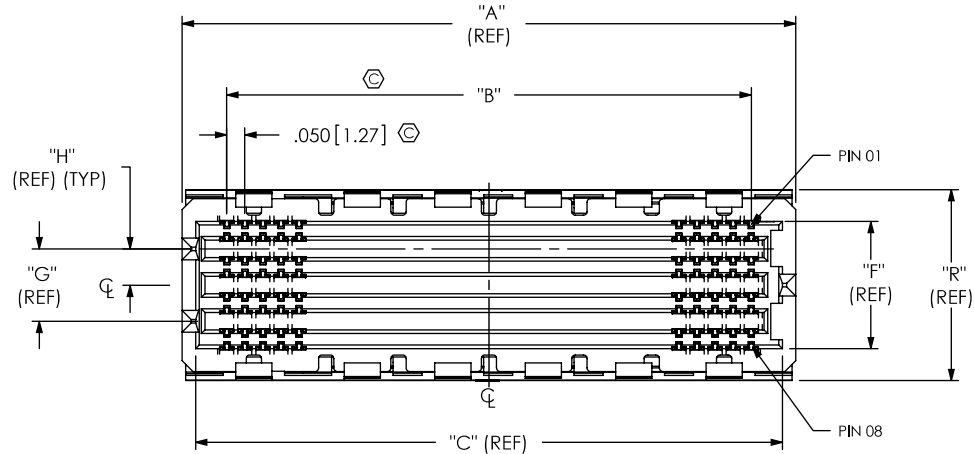

-07.0 LEAD STYLE
(SEAM-XX-07.0-X-08-A-X SHOWN)

TABLE 9
STACK HEIGHT

SEAM-S LEAD STYLE	SEAM LEAD STYLE			
	-05.0	-06.0	-06.5	-07.5
-6.5	11.5mm	12.5mm	13mm	14mm
-07.0	12mm	13mm	13.5mm	14.5mm
-09.0	14mm	15mm	15.5mm	16.5mm
-11.0	16mm	17mm	17.5mm	18.5mm
*-13.0	18mm	19mm	19.5mm	20.5mm

* = NOT TOOLED

TABLE 10

ROW	STYLE	"P"	"Q"	"R"	SPACER BODY	TOP BODY	TERMINAL
-04	-07.0	.271 [6.88]	.417 [10.60]	.328 [8.33]	SEAM-S-XX-07.0-04-X	SEAM-XX-00.1-04	SUB-T-1M38-07.0-XX
	-09.0	.350 [8.89]	.496 [12.60]	.328 [8.33]	SEAM-S-XX-09.0-04-X	SEAM-XX-00.1-04	SUB-T-1M38-09.0-XX
	-11.0	.429 [10.90]	.575 [14.60]	.328 [8.33]	SEAM-S-XX-11.0-04-X	SEAM-XX-00.1-04	SUB-T-1M38-11.0-XX
-05	-07.0	.271 [6.88]	.417 [10.60]	.428 [10.87]	SEAM-S-XX-07.0-06-X	SEAM-XX-00.1-05	SUB-T-1M38-07.0-XX
	-09.0	.350 [8.89]	.496 [12.60]	.428 [10.87]	SEAM-S-XX-09.0-06-X	SEAM-XX-00.1-05	SUB-T-1M38-09.0-XX
	-11.0	.429 [10.90]	.575 [14.60]	.428 [10.87]	SEAM-S-XX-11.0-06-X	SEAM-XX-00.1-05	SUB-T-1M38-11.0-XX
	*-13.0	.508 [12.90]	.654 [16.60]	.428 [10.87]	SEAM-S-XX-13.0-06-X	SEAM-XX-00.1-05	SUB-T-1M38-13.0-XX
-06	-07.0	.271 [6.88]	.417 [10.60]	.428 [10.87]	SEAM-S-XX-07.0-08-X	SEAM-XX-00.1-06	SUB-T-1M38-07.0-XX
	-09.0	.350 [8.89]	.496 [12.60]	.428 [10.87]	SEAM-S-XX-09.0-08-X	SEAM-XX-00.1-06	SUB-T-1M38-09.0-XX
	-11.0	.429 [10.90]	.575 [14.60]	.428 [10.87]	SEAM-S-XX-11.0-08-X	SEAM-XX-00.1-06	SUB-T-1M38-11.0-XX
	*-13.0	.508 [12.90]	.654 [16.60]	.428 [10.87]	SEAM-S-XX-13.0-08-X	SEAM-XX-00.1-06	SUB-T-1M38-13.0-XX
-08	-06.5	.252 [6.40]	.400 [10.16]	.528 [13.41]	SEAM-S-XX-06.5-08-X	SEAM-XX-00.1-08	SUB-T-1M38-06.5-XX
	-07.0	.271 [6.88]	.417 [10.60]	.528 [13.41]	SEAM-S-XX-07.0-08-X	SEAM-XX-00.1-08	SUB-T-1M38-07.0-XX
	-09.0	.350 [8.89]	.496 [12.60]	.528 [13.41]	SEAM-S-XX-09.0-08-X	SEAM-XX-00.1-08	SUB-T-1M38-09.0-XX
	-11.0	.429 [10.90]	.575 [14.60]	.528 [13.41]	SEAM-S-XX-11.0-08-X	SEAM-XX-00.1-08	SUB-T-1M38-11.0-XX
-10	*-13.0	.508 [12.90]	.654 [16.60]	.528 [13.41]	SEAM-S-XX-13.0-08-X	SEAM-XX-00.1-08	SUB-T-1M38-13.0-XX
	-06.5	.252 [6.40]	.400 [10.16]	.628 [15.95]	SEAM-S-XX-06.5-10-X	SEAM-XX-00.1-10	SUB-T-1M38-06.5-XX
	-07.0	.271 [6.88]	.417 [10.60]	.628 [15.95]	SEAM-S-XX-07.0-10-X	SEAM-XX-00.1-10	SUB-T-1M38-07.0-XX
	-09.0	.350 [8.89]	.496 [12.60]	.628 [15.95]	SEAM-S-XX-09.0-10-X	SEAM-XX-00.1-10	SUB-T-1M38-09.0-XX
	-11.0	.429 [10.90]	.575 [14.60]	.628 [15.95]	SEAM-S-XX-11.0-10-X	SEAM-XX-00.1-10	SUB-T-1M38-11.0-XX
	*-13.0	.508 [12.90]	.654 [16.60]	.628 [15.95]	SEAM-S-XX-13.0-10-X	SEAM-XX-00.1-10	SUB-T-1M38-13.0-XX

* = NOT TOOLED

PROPRIETARY NOTE

THIS DOCUMENT CONTAINS INFORMATION CONFIDENTIAL AND PROPRIETARY TO SAMTEC, INC. AND SHALL NOT BE REPRODUCED OR TRANSMITTED IN ANY FORM OR BY ANY MEANS, ELECTRONIC OR MECHANICAL, INCLUDING PHOTOCOPYING, RECORDING, OR BY ANY INFORMATION STORAGE AND RETRIEVAL SYSTEM, WITHOUT THE EXPRESS WRITTEN CONSENT OF SAMTEC, INC.

DO NOT SCALE DRAWING

SHEET SCALE: 2:1



520 PARK EAST BLVD, NEW ALBANY, IN 47150
PHONE: 812-944-6733 FAX: 812-948-5047
e-Mail info@SAMTEC.com code 55322

DESCRIPTION:
_050 PITCH TERMINAL ARRAY ASSEMBLY
DWG. NO.
SEAM-XX-XX.X-XX-XX-X-A-XX-K-TR
BY: BRATCHER 08-09-2010 SHEET 3 OF 8

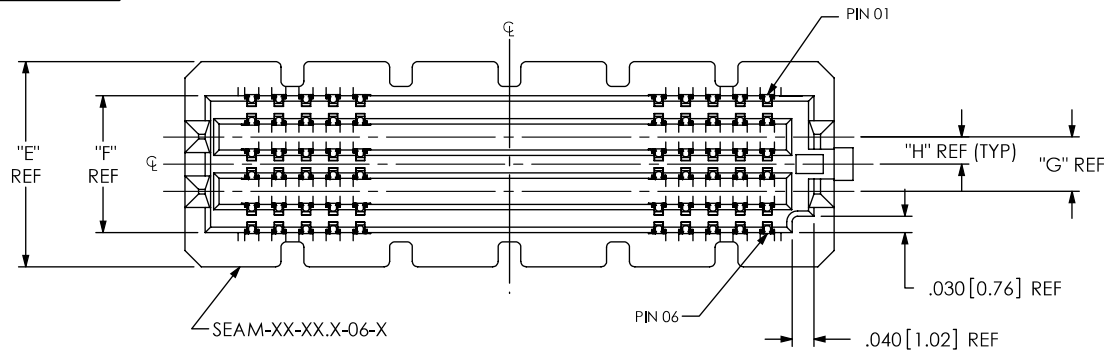

FIG. 6
-06: 6 ROWS
(SAME AS FIG. 1, EXCEPT AS SHOWN)
(SEAM-20-02.0-XX-06-X-A-XX-K-TR SHOWN)
(SOME CENTER FEATURES, INCLUDING -K, NOT SHOWN FOR CLARITY)

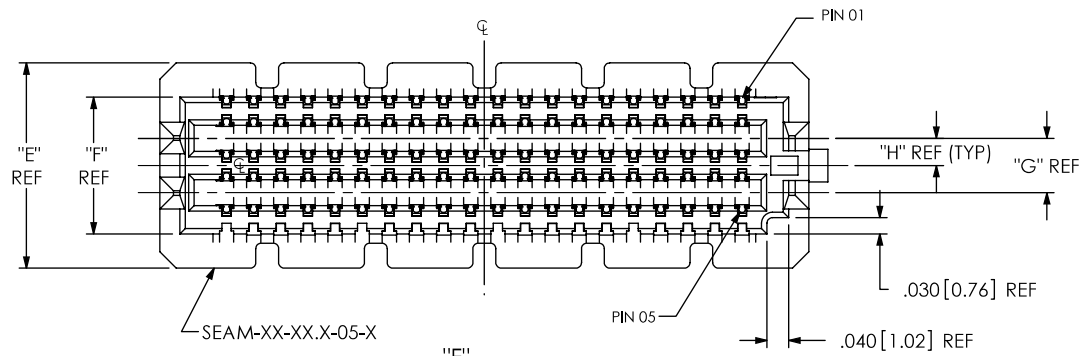
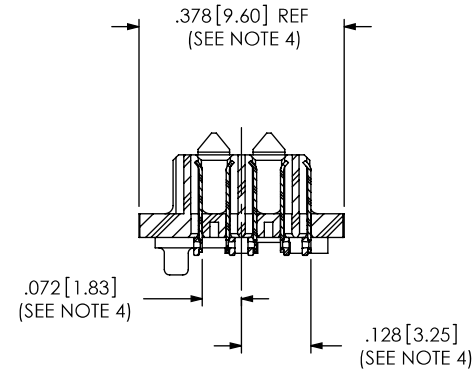
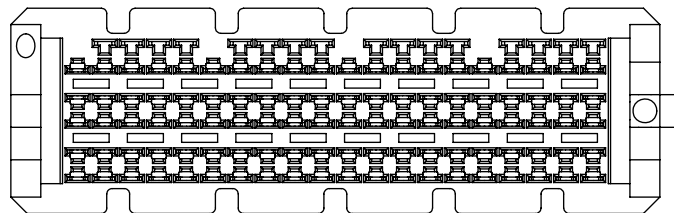
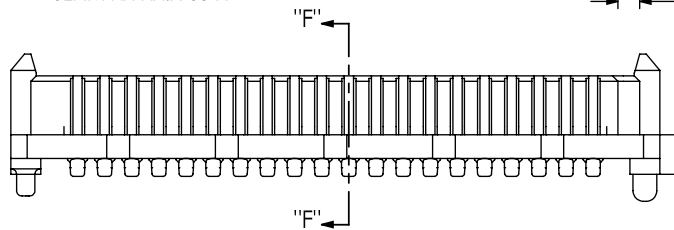

FIG. 7
-05: 5 ROWS
(SAME AS FIG. 6, EXCEPT AS SHOWN)
(SEAM-20-02.0-XX-05-X-A-XX-K-TR SHOWN)
(SEE NOTE 4)



SECTION "F"-"F"

PROPRIETARY NOTE

THIS DOCUMENT CONTAINS INFORMATION CONFIDENTIAL AND PROPRIETARY TO SAMTEC, INC. AND SHALL NOT BE REPRODUCED OR TRANSFERRED TO OTHER DOCUMENTS OR DISCLOSED TO OTHERS OR USED FOR ANY PURPOSE OTHER THAN THAT WHICH IT WAS OBTAINED WITHOUT THE EXPRESSED WRITTEN CONSENT OF SAMTEC, INC.

DO NOT SCALE DRAWING

SHEET SCALE: 3:1



520 PARK EAST BLVD, NEW ALBANY, IN 47150
PHONE: 812-944-6733 FAX: 812-948-5047
e-Mail info@SAMTEC.com code 55322

DESCRIPTION:

.050 PITCH TERMINAL ARRAY ASSEMBLY

DWG. NO.

SEAM-XX-XX.X-XX-XX-X-A-XX-K-TR

BY: BRATCHER 08-09-2010

SHEET 4 OF 8

REVISION AY

FIG. 8

-GP: GUIDE POST OPTION
 (ONLY AVAILABLE WITH -.02.0 LEAD STYLE, 20, 30, 40, & 50 POSITIONS)
 (MATES WITH SEAF RIGHT ANGLE ONLY)
 (SAME AS FIG. 1, EXCEPT AS SHOWN)
 (SEAM-20-02.0-XX-06-2-A-GP-K-TR SHOWN)
 (SOME CONTACTS NOT SHOWN FOR CLARITY)

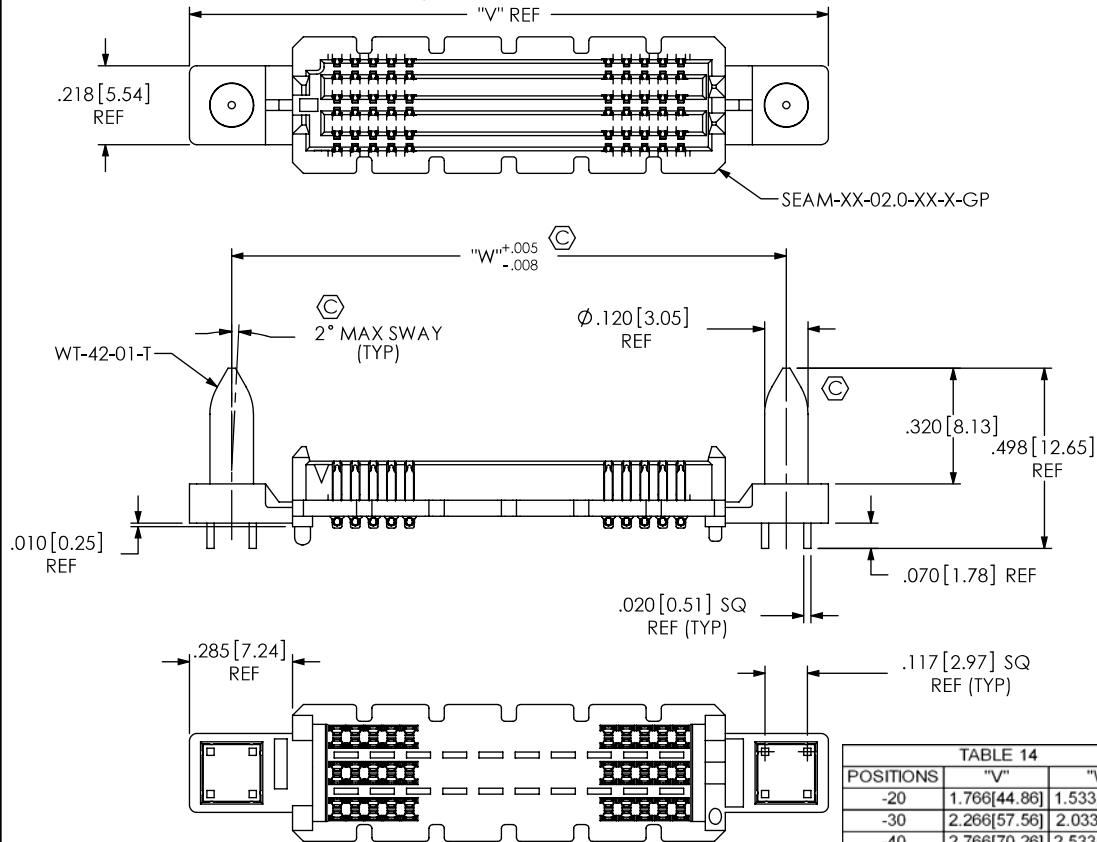

POSITIONS	"V"	"W"
-20	1.766[44.86]	1.533[38.94]
-30	2.266[57.56]	2.033[51.64]
-40	2.766[70.26]	2.533[64.34]
-50	3.266[82.96]	3.033[77.04]

FIG. 10

-EP: EXTENDED GUIDE POST OPTION
 (ONLY AVAILABLE WITH -.02.0 & -.03.5 LEAD STYLES,
 20, 30, 40, & 50 POSITIONS)
 (SAME AS FIG. 8, EXCEPT AS SHOWN)
 (SEAM-20-03.5-XX-06-2-A-EP-K-TR SHOWN)
 (SOME CONTACTS NOT SHOWN FOR CLARITY)

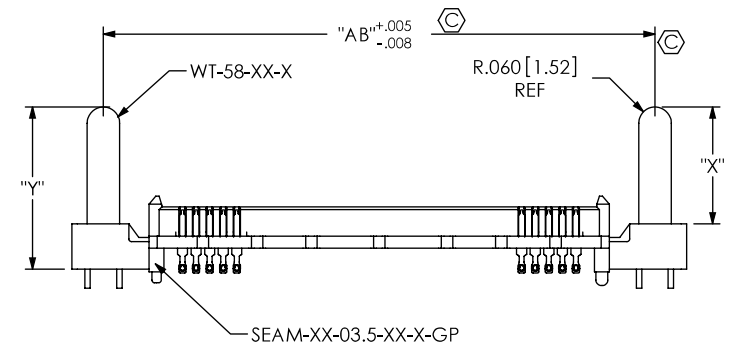

LEAD STYLE	"X"	"Y"	GUIDE POST
-02.0	.372[9.45]	.539[13.69]	WT-58-01-T
-03.5	.431[10.95]	.598[15.19]	WT-58-02-T

SEAM LEAD STYLE	SEAF LEAD STYLE	STACK HEIGHT
-02.0	-05.0	7MM
-03.5	-06.5	10MM

POSITIONS	"AB"
-20	1.533[38.94]
-30	2.033[51.64]
-40	2.533[64.34]
-50	3.033[77.04]

PROPRIETARY NOTE

THIS DOCUMENT CONTAINS INFORMATION CONFIDENTIAL AND PROPRIETARY TO SAMTEC, INC. AND SHALL NOT BE REPRODUCED OR TRANSFERRED TO OTHER DOCUMENTS OR DISCLOSED TO OTHERS OR USED FOR ANY PURPOSE OTHER THAN THAT WHICH IT WAS OBTAINED WITHOUT THE EXPRESSED WRITTEN CONSENT OF SAMTEC, INC.

DO NOT SCALE DRAWING

SHEET SCALE: 2:1



520 PARK EAST BLVD, NEW ALBANY, IN 47150
 PHONE: 812-944-6733 FAX: 812-948-5047
 e-Mail info@SAMTEC.com code 55322

DESCRIPTION:
 .050 PITCH TERMINAL ARRAY ASSEMBLY
 DWG. NO.
 SEAM-XX-XX.X-XX-XX-X-A-XX-K-TR

BY: BRATCHER 08-09-2010 SHEET 5 OF 8

FIG. 9
 -04: 4 ROW
 (SAME AS FIG. 1, EXCEPT AS SHOWN)
 (SEAM-20-02.0-XX-04-1-A-XX-K-TR SHOWN)
 (SOME CENTER FEATURES, INCLUDING -K, NOT SHOWN FOR CLARITY)

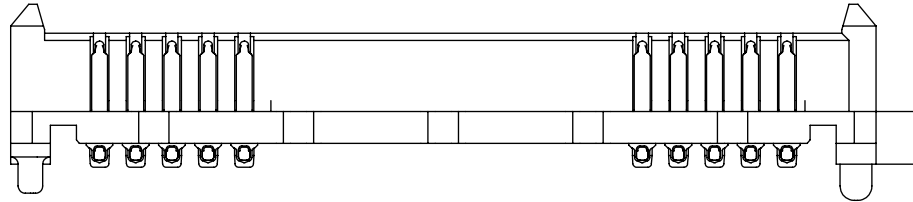
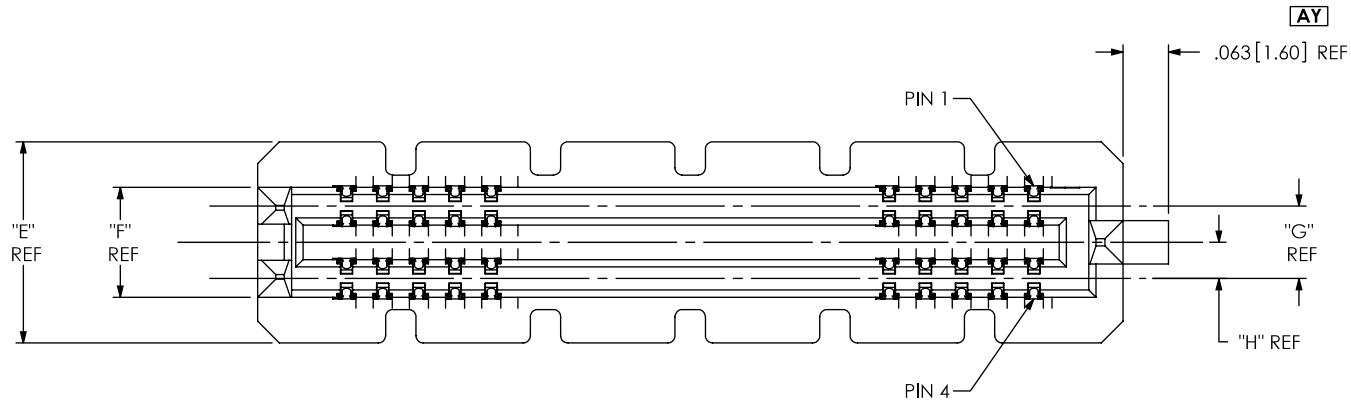

PROPRIETARY NOTE

THIS DOCUMENT CONTAINS INFORMATION CONFIDENTIAL AND PROPRIETARY TO SAMTEC, INC. AND SHALL NOT BE REPRODUCED OR TRANSFERRED TO OTHER DOCUMENTS OR DISCLOSED TO OTHERS OR USED FOR ANY PURPOSE OTHER THAN THAT WHICH IT WAS OBTAINED WITHOUT THE EXPRESSED WRITTEN CONSENT OF SAMTEC, INC.

DO NOT SCALE DRAWING

SHEET SCALE:4:1



520 PARK EAST BLVD, NEW ALBANY, IN 47150
 PHONE: 812-944-6733 FAX: 812-948-5047
 e-Mail info@SAMTEC.com code 55322

DESCRIPTION:
 .050 PITCH TERMINAL ARRAY ASSEMBLY

DWG. NO.
 SEAM-XX-XX.X-XX-XX-X-A-XX-K-TR

BY: BRATCHER 08-09-2010 SHEET 6 OF 8

FIG. 11

(SAME AS FIG. 1, EXCEPT AS SHOWN)
 (SEAM-19-05.5-XX-06-A-K-TR SHOWN)
 (ONLY AVAILABLE ON THE 6 ROW 19 POSITION)

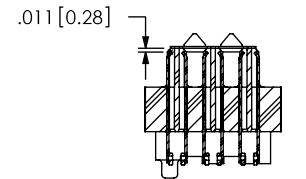
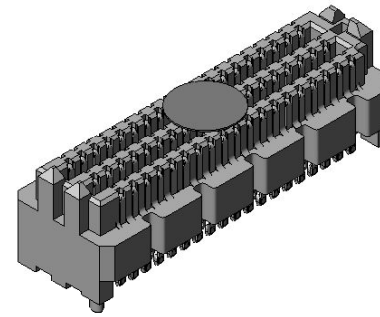
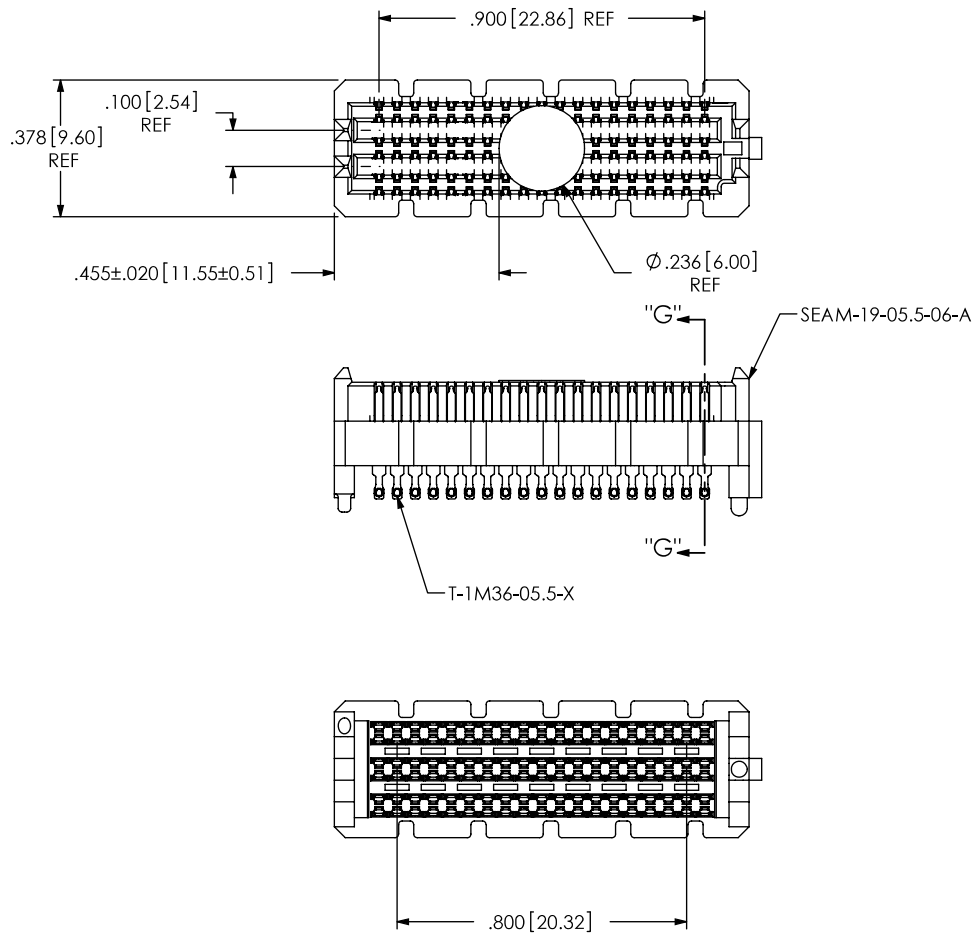

SECTION "G"-"G"

PROPRIETARY NOTE

THIS DOCUMENT CONTAINS INFORMATION CONFIDENTIAL AND PROPRIETARY TO SAMTEC, INC. AND SHALL NOT BE REPRODUCED OR TRANSFERRED TO OTHER DOCUMENTS OR DISCLOSED TO OTHERS OR USED FOR ANY PURPOSE OTHER THAN THAT WHICH IT WAS OBTAINED WITHOUT THE EXPRESSED WRITTEN CONSENT OF SAMTEC, INC.

DO NOT SCALE DRAWING

SHEET SCALE: 2:1



520 PARK EAST BLVD, NEW ALBANY, IN 47150
 PHONE: 812-944-6733 FAX: 812-948-5047
 e-Mail info@SAMTEC.com code 55322

DESCRIPTION:
 .050 PITCH TERMINAL ARRAY ASSEMBLY

DWG. NO.
 SEAM-XX-XX.X-XX-XX-X-A-XX-K-TR

BY: BRATCHER 08-09-2010 SHEET 7 OF 8

FIG. 12
 CRIMP TAIL DETAILS
 (SEAM-30-02.0-XX-08-X-A-XX-K-TR SHOWN)
 (SAME AS FIG. 1 UNLESS OTHERWISE SPECIFIED)
 (ONLY AVAILABLE ON -02.0, -03.0 & -03.5 LEAD STYLES)
 (SOME CENTER FEATURES, INCLUDING -K, NOT SHOWN FOR CLARITY)

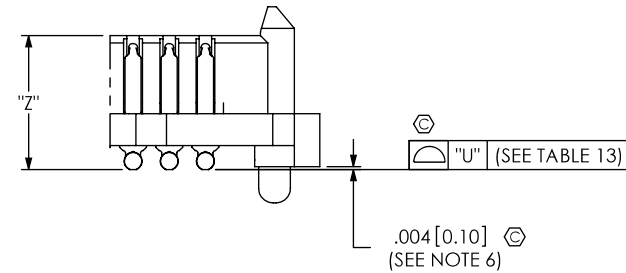
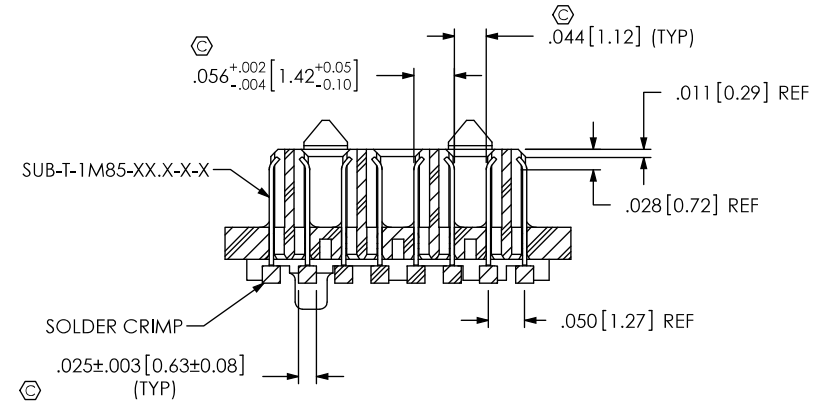
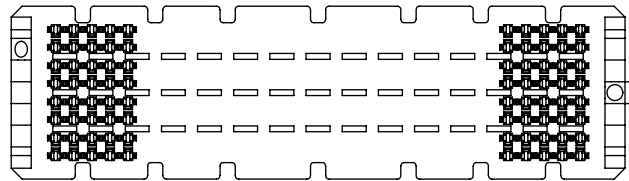
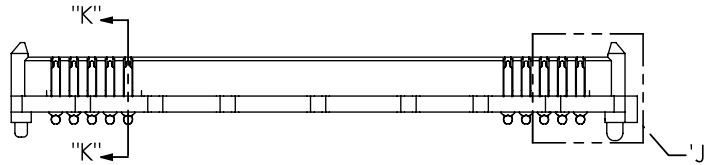

LEAD STYLE	"Z"
-02.0	.1850 [4.699]
-03.0	.2240 [5.690]
-03.5	.2420 [6.147]

<p>PROPRIETARY NOTE THIS DOCUMENT CONTAINS INFORMATION CONFIDENTIAL AND PROPRIETARY TO SAMTEC, INC. AND SHALL NOT BE REPRODUCED OR TRANSFERRED TO OTHER DOCUMENTS OR DISCLOSED TO OTHERS OR USED FOR ANY PURPOSE OTHER THAN THAT WHICH IT WAS OBTAINED WITHOUT THE EXPRESSED WRITTEN CONSENT OF SAMTEC, INC.</p> <p>DO NOT SCALE DRAWING</p> <p>SHEET SCALE: 2:1</p>	 <p>520 PARK EAST BLVD, NEW ALBANY, IN 47150 PHONE: 812-944-6733 FAX: 812-948-5047 e-Mail: info@SAMTEC.com code 55322</p>	
	<p>DESCRIPTION: .050 PITCH TERMINAL ARRAY ASSEMBLY</p>	
	<p>DWG. NO. SEAM-XX-XX.X-XX-XX-X-A-XX-K-TR</p>	
	<p>BY: BRATCHER 08-09-2010</p>	<p>SHEET 8 OF 8</p>