

DO NOT SCALE FROM THIS PRINT

FIG. 1
-LC: LOCKING CLIP OPTION SHOWN

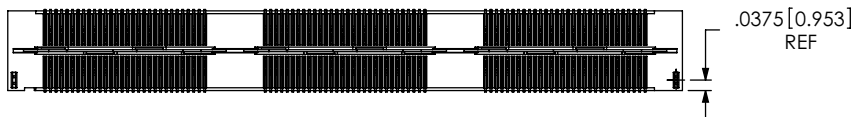
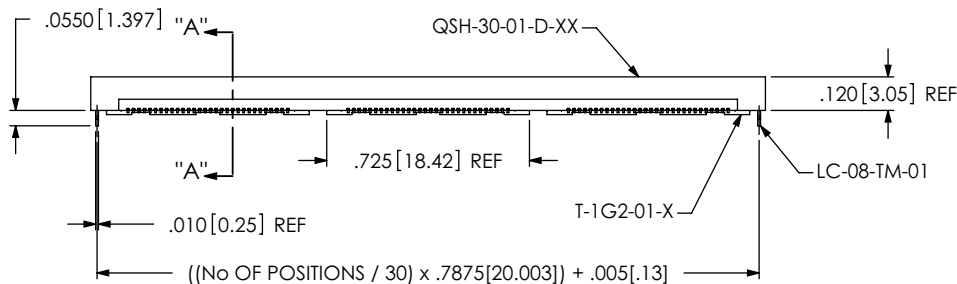
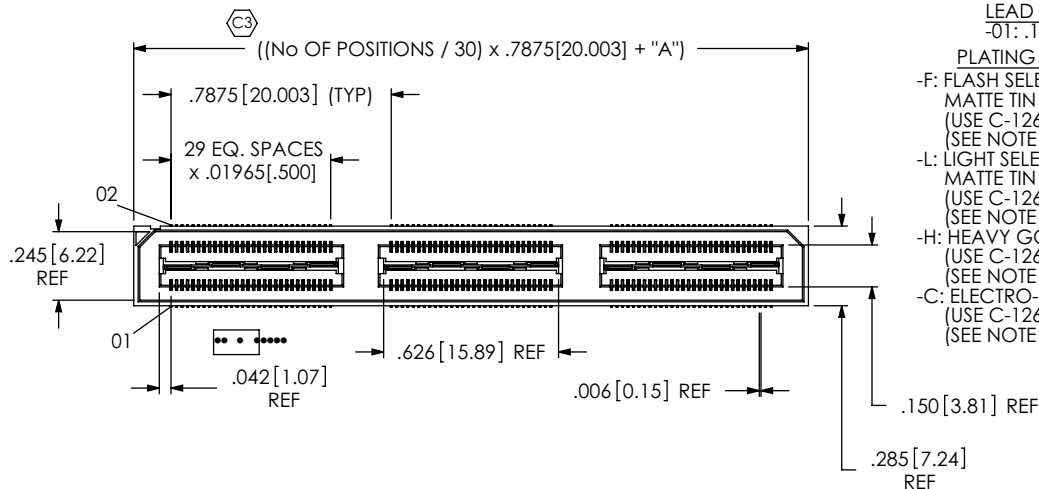

No OF POS	COPLANARITY INCLUDING GROUND PLANE
-030 THRU -060	.0040[.102]
-090 THRU -150	.0060[.152]

No OF BANKS	"A"
1-2	.0515
3-4	.0540
5	.0535

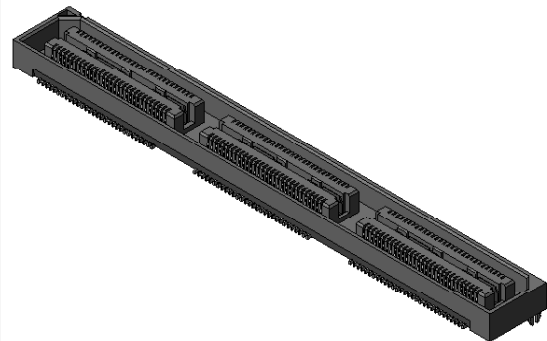

QSH-XXX-01-X-D-XXX

No OF POSITIONS
-030, -060, -090,
* -120, * -150
(PER ROW)
* SEE NOTE 11
LEAD STYLE
-01: .1280[3.25]

PLATING SPECIFICATION
-F: FLASH SELECTIVE GOLD WITH MATTE TIN TAILS (USE C-126-21-F, T-1G2-01-F) (SEE NOTE 8 & 10) * SEE NOTE 12
-L: LIGHT SELECTIVE GOLD WITH MATTE TIN TAILS (USE C-126-21-L, T-1G2-01-L) (SEE NOTE 10) * SEE NOTE 12
-H: HEAVY GOLD (USE C-126-21-H, T-1G2-01-G) (SEE NOTE 10) * SEE NOTE 12
-C: ELECTRO-POLISHED SELECTIVE (USE C-126-21-C, T-1G2-01-L) (SEE NOTE 10) * SEE NOTE 12

OPTION
-A: ALIGNMENT PINS (USE QSH-30-01-D-XX-A, SEE FIG. 2)
-LC: LOCKING CLIPS (USE LC-08-TM-01)
-GP: GUIDE POSTS (USE QSH-30-01-D-XX-X-GP) (SEE FIG. 4, SHEET 3)
-K: POLYIMIDE FILM PAD (USE K-DOT-325-.450-.005, SEE FIG. 3)
-TR: TAPE & REEL (90 POS MAX)
-FL: FRICTION LOCKS (SEE FIG. 5, SHEET 3) (NOT AVAILABLE WITH -GP)
-RT1: RETENTION (MUST USE -A OPTION) (USE QSH-30-01-D-XX-A-RT1 & SUB-SC-05-01-FF) (SEE FIG. 6, SHEET 3) (NOT AVAILABLE WITH -LC, -GP, OR -FL) (NOT AVAILABLE WITH -120 & -150 POS)

ROW SPECIFICATION

-D: DOUBLE (USE QSH-30-01-D-XX)

No OF BANKS

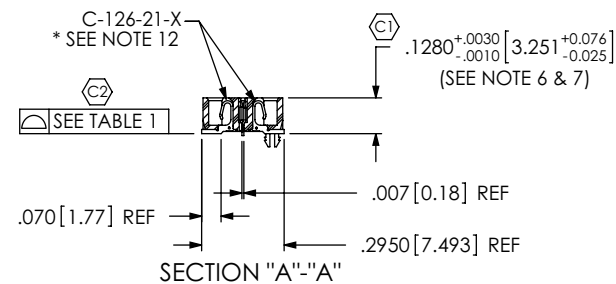

NOTES:

1. $\text{\textcircled{C}}$ REPRESENTS A CRITICAL DIMENSION.
2. NOTE DELETED.
3. CONTACT RETENTION: 8 OZ. MINIMUM.
4. GROUND PLANE RETENTION: 8 OZ. MINIMUM.
5. BURR ALLOWANCE: .0015[.038] MAX.
6. MAX VARIANCE: .002[.05].
7. DIMENSION APPLIES TO CONTACT & GROUND PLANE.
8. -L PLATING CAN BE SUBSTITUTED FOR -F PLATING.
9. SUB-SC-05-01-XX RETENTION TO BE 1.0 LBF IN BODY.
10. MAY SUB C-126-01 FOR C-126-21.
11. FOR NEW APPLICATIONS REQUIRING THESE POSITIONS, PLEASE CONTACT SAMTEC INTERCONNECT PROCESSING GROUP.
12. FOR -120, -150 POSITIONS USE C-269-01-X. DO NOT SUB C-126.

UNLESS OTHERWISE SPECIFIED, DIMENSIONS ARE IN INCHES. TOLERANCES ARE:
DECIMALS ANGLES
.XX: $\pm .01[.3]$ 2°
.XXX: $\pm .005[.13]$
.XXXX: $\pm .0020[.051]$

PROPRIETARY NOTE
THIS DOCUMENT CONTAINS INFORMATION CONFIDENTIAL AND PROPRIETARY TO SAMTEC, INC. AND SHALL NOT BE REPRODUCED OR TRANSFERRED TO OTHER DOCUMENTS OR DISCLOSED TO OTHERS OR USED FOR ANY PURPOSE OTHER THAN THAT WHICH IT WAS OBTAINED WITHOUT THE EXPRESSED WRITTEN CONSENT OF SAMTEC, INC.



520 PARK EAST BLVD, NEW ALBANY, IN 47150
PHONE: 812-944-6733 FAX: 812-948-5047
e-Mail: info@SAMTEC.com code: 55322

MATERIAL: DO NOT SCALE DRAWING SHEET SCALE: 1:30.664

INSULATOR: BLACK LCP
CONTACT & GROUND PLANE: PHOS BRONZE

DESCRIPTION:
.5mm DOUBLE ROW HS SOCKET ASSEMBLY

DWG. NO. QSH-XXX-01-X-D-XXX

BY: DEAN P 05/21/1999 SHEET 1 OF 3

FIG. 2
-A: ALIGNMENT PIN OPTION

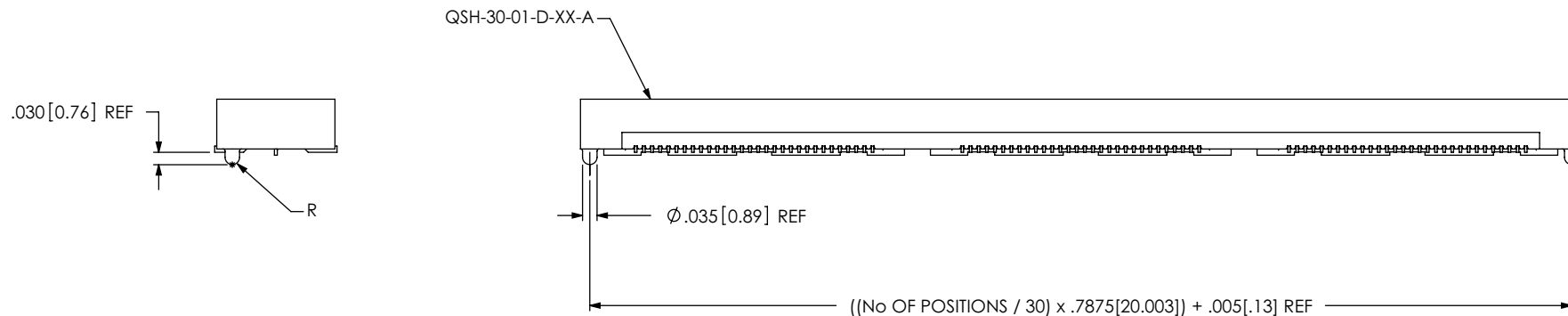
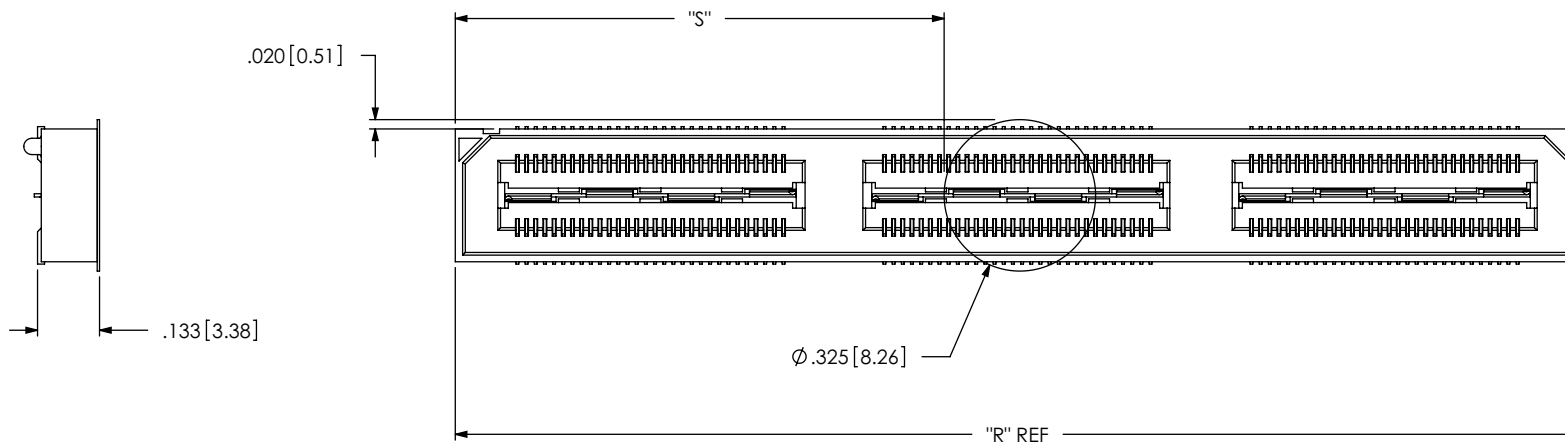



FIG. 3
-K: POLYIMIDE FILM PAD
[USE K-DOT-.325-.450-.005]



NOTE: "R" = ((No OF POSITIONS / 30) x .7875 [20.003]) + .050 [1.27]
 WITH -RT1 OPTION: "R" = ((No OF POSITIONS / 30) x .7875 [20.003]) + .650 [16.51] REF
 WITH -GP OPTION: "R" = ((No OF POSITIONS / 30) x .7875 [20.003]) + .4285 [10.884] REF
 "S" = ("R" - .325 [8.26]) / 2 ± .020 [0.51]

<p>PROPRIETARY NOTE</p> <p>THIS DOCUMENT CONTAINS INFORMATION CONFIDENTIAL AND PROPRIETARY TO SAMTEC, INC. AND SHALL NOT BE REPRODUCED OR TRANSFERRED TO OTHER DOCUMENTS OR DISCLOSED TO OTHERS OR USED FOR ANY PURPOSE OTHER THAN THAT WHICH IT WAS OBTAINED WITHOUT THE EXPRESSED WRITTEN CONSENT OF SAMTEC, INC.</p> <p>DO NOT SCALE DRAWING</p> <p>SHEET SCALE: 2.5:1</p>		
	<p>520 PARK EAST BLVD, NEW ALBANY, IN 47150 PHONE: 812-944-6733 FAX: 812-948-5047 e-Mail: info@SAMTEC.com code: 55322</p>	
<p>DESCRIPTION: .5mm DOUBLE ROW HS SOCKET ASSEMBLY</p>		
<p>DWG. NO. QSH-XXX-01-X-D-XXX</p>		
<p>BY: DEAN P 05/21/1999 SHEET 2 OF 3</p>		

REVISION AE

FIG. 4

-GP: GUIDE POSTS
(SAME AS FIG. 1, UNLESS OTHERWISE STATED)

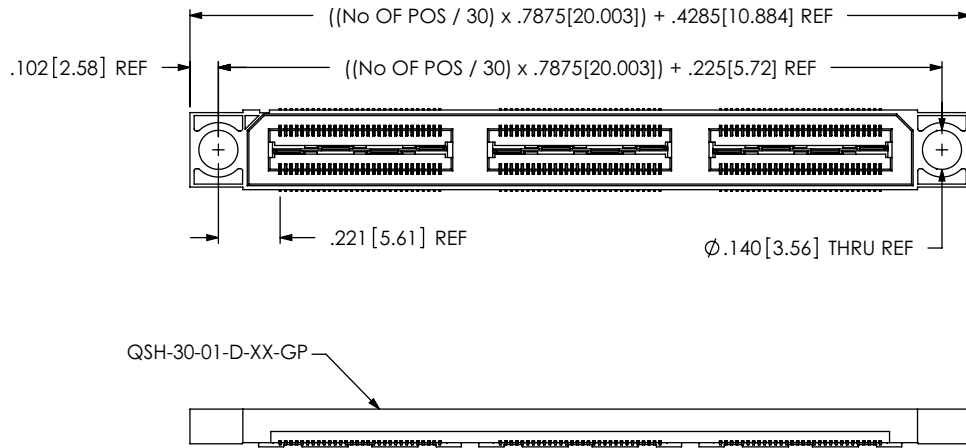

FIG. 5

-FL: FRICTION LOCKS
(NOT AVAILABLE WITH -GP OPTION)
(SAME AS FIG. 1, UNLESS OTHERWISE STATED)

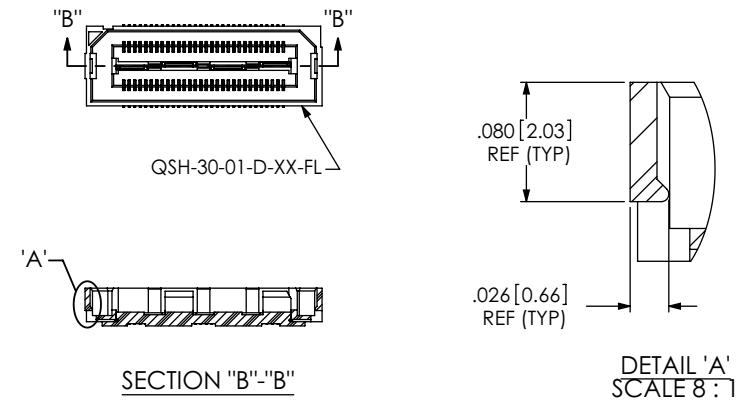
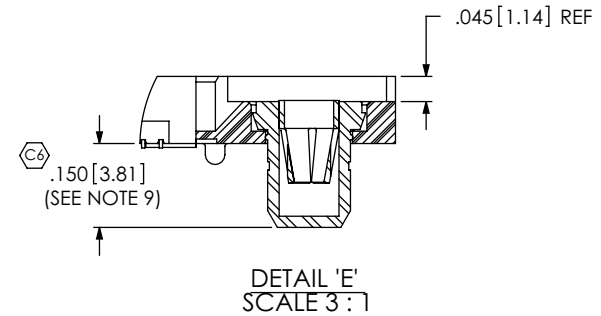
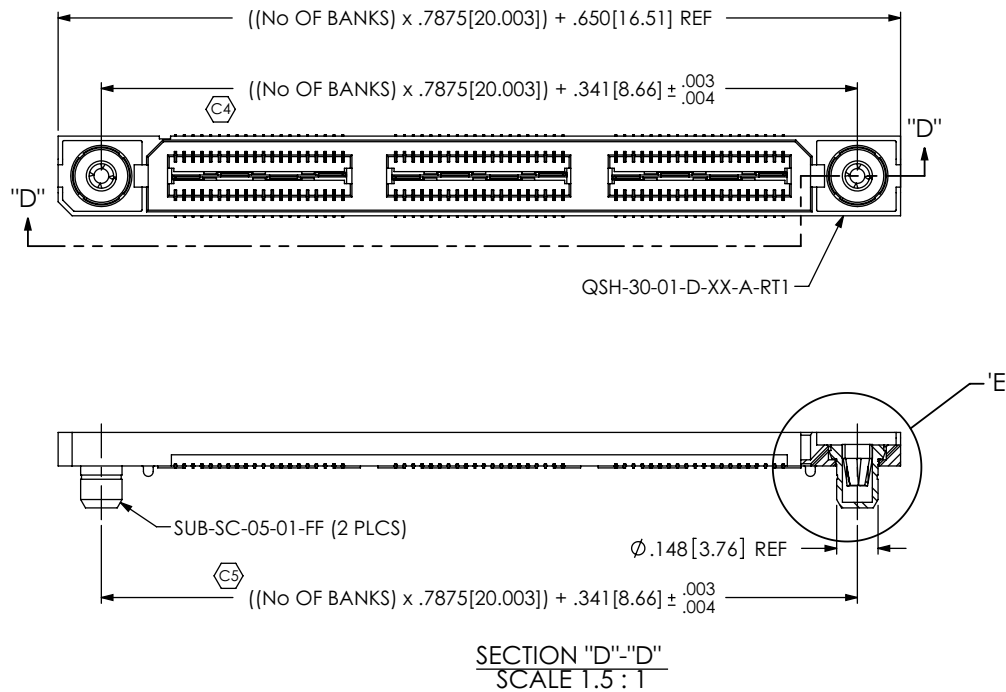

FIG. 6

-RT1: RETENTION OPTION
(MUST USE -A OPTION)
(NOT AVAILABLE WITH -LC, -GP, OR -FL OPTIONS)
(NOT AVAILABLE WITH -120 & -150 POS)
(SAME AS FIG. 1, UNLESS OTHERWISE STATED)



PROPRIETARY NOTE
THIS DOCUMENT CONTAINS INFORMATION
CONFIDENTIAL AND PROPRIETARY TO
SAMTEC, INC. AND SHALL NOT BE REPRODUCED
OR TRANSFERRED TO OTHER DOCUMENTS OR
DISCLOSED TO OTHERS OR USED FOR ANY
PURPOSE OTHER THAN THAT WHICH IT WAS
OBTAINED WITHOUT THE EXPRESSED WRITTEN
CONSENT OF SAMTEC, INC.

DO NOT SCALE DRAWING

SHEET SCALE: 1.5:1

samtec

520 PARK EAST BLVD, NEW ALBANY, IN 47150
PHONE: 812-944-6733 FAX: 812-948-5047
e-Mail: info@SAMTEC.com code: 55322

DESCRIPTION:
.5mm DOUBLE ROW HS SOCKET ASSEMBLY

DWG. NO.
QSH-XXX-01-X-D-XXX

BY: DEAN P 05/21/1999 SHEET 3 OF 3